



## **AGENDA – Regular Meeting of Council**

**Wednesday, March 02, 2022**

**1:00 PM**

**Magnetawan Community Centre**

### **Page # OPENING BUSINESS**

- 1.1 Call to Order
- 1.2 Adoption of the Agenda
- 1.3 Disclosure of Pecuniary Interest
- 3 1.4 Adoption of Previous Minutes

### **DEPUTATION**

- 8 Rev Sylvia Poetschke - Support to Install, Maintain and Stock a Community Food Pantry

### **STAFF REPORTS, MOTIONS AND DISCUSSION**

- 15 2.1 Report from Fire Chief Joe Readman, Update to Fire Protection and Prevention Act, Mandatory Certification for Firefighters
- 36 2.2 Correspondence from the Joint Building Committee, Request for Sharing Services for Emergencies
- 37 2.3 Report from Public Works Superintendent Scott Edwards, Truck #20 Replacement
- 39 2.4 Report from Treasurer Linda Saunders, Schedule of Investments
- 41 2.5 Deeming By-law Request Collin James - PT Lot 11 W/S N and PT Lots 11 & 12 in Plan 319
- 45 2.6 Ecovue Consulting Services, Background Report, Official Plan and Zoning By-law Review and Update
- 57 2.7 DRAFT Appoint Council as Committee of Adjustment 2022
- 58 2.8 Request for Funding Burks Falls Almaguin Highlands Health Centre (AHC)
- 64 2.9 Correspondence from Rev. Dr. Peter Wyatt, Requesting Chapman Road Rubbish Clean Up
- 65 2.10 Draft Motion Northern Ontario Heritage Fund Corporation (NOHFC) Magnetawan Community Centre Roof and Pavilion Outdoor Rink
- 66 2.11 Draft Motion Ghost Gravel August 2022
- 69 2.12 Correspondence from Chris Barry and Alaina Cawston, Magnetawan Park Gazebo July 2022
- 73 2.13 Almaguin Highlands Community Safety and Well-Being Plan 2021-2025 & Survey Results

### **MUNICIPAL BOARDS AND COMMITTEE MINUTES**

- 167 3.1 Almaguin Community Economic Development (ACED) Minutes January 17, 2021, 2021 Annual Report, 2022 Work Plan, & 2022 Budget Sheets
- 203 3.2 Magnetawan Community Development Committee (MCDC) Minutes, February 15, 2022
- 207 3.3 Magnetawan Community Centre Board (MCCB) Minutes, February 16, 2022

### **CORRESPONDENCE**

- 210 4.1 North Bay & Parry Sound Health Unit, 2022 Municipal Levy
- 215 4.2 RFP 2022-02 Request for Proposal Contractor - Replacement of Boat Ramp 4195 ON-520
- 223 4.3 RFP 2022-03 Request for Proposal Contractor - Roof Repair/Replacement Municipal Office Building
- 232 4.4 Magnetawan-Cedar Croft Netspectrum Rural Internet Tower
- 233 4.5 February 2022 Newsletter
- 235 4.6 The Great Northern Ontario Roadshow Poster
- 236 4.7 New Municipal Hours Poster
- 237 4.8 ICYMI Council Highlights February 09, 2022

### **ACCOUNTS**

- 238 5.1 Accounts in the amount of \$324,055.87

### **BY-LAWS**

- 256 6.1 Appoint Council as Committee of Adjustment 2022

### **CLOSED SESSION**

In accordance with Section 239(2) of the Municipal Act, 2001, S.O. 2001, c.25, as amended, Council shall proceed into Closed Session in order to address matters pertaining to:

- (c) a proposed or pending acquisition or disposition of land by the municipality
- (d) labour relations or employee negotiations
- (e) litigation or potential litigation

### **CONFIRMING BY-LAW AND ADJOURNMENT**

- 257 7.1 Confirm the Proceedings of Council and Adjourn



**COUNCIL MEETING MINUTES**  
**February 09, 2022**  
**1:00 pm**

The meeting of the Council of the Corporation of the Municipality of Magnetawan was held at the Magnetawan Community Centre on Wednesday February 09, 2022 with the following present:

Mayor Sam Dunnett  
Councillor John Hetherington  
Councillor Brad Kneller  
Councillor Wayne Smith

Regrets:  
Deputy Mayor Tim Brunton

Staff: CAO/Clerk Kerstin Vroom, Deputy Clerk Recreation and Communications Laura Brandt, Deputy Clerk Planning and Development Nicole Gourlay and Public Works Superintendent Scott Edwards were present for the entire meeting.

**OPENING BUSINESS**

**1.1 Call to Order**

The meeting was called to order at 1:00 p.m.

**1.2 Adoption of the Agenda**

*RESOLUTION 2022-27 Smith-Hetherington*

*BE IT RESOLVED THAT the Council of the Municipality of Magnetawan adopts the agenda as presented.*

*Carried.*

**1.3 Disclosure of Pecuniary Interest**

Mayor Dunnett stated that should anyone have a disclosure of pecuniary interest that they could declare the nature thereof now or at any time during the meeting.

\*Councillor John Hetherington declared a pecuniary interest for Agenda item 2.3 due to being a member of the Almaguin Community Hatchery Program.

#### **1.4 Adoption of the Previous Minutes**

*RESOLUTION 2022-28 Kneller-Smith*

*BE IT RESOLVED THAT the Council of the Municipality of Magnetawan adopts the minutes of the meetings on January 19, 2022 at 10:00 am and 1:00 pm as copied and circulated.*

*Carried.*

#### **PROCLAMATION**

##### **Year of the Garden 2022**

*RESOLUTION 2022-29 Kneller-Hetherington*

*WHEREAS Communities in Bloom and "Fleurons du Québec" in collaboration with the Canadian Garden Council, invite all municipalities to celebrate the Year of the Garden 2022;*

*AND WHEREAS the Year of the Garden 2022 celebrates the Centennial of Canada's horticulture sector;*

*AND WHEREAS gardens and gardening contribute to the quality of life of our municipality, our*

*climate action goals and create safe and healthy places where people can come together in the spirit of inclusivity and reconciliation;*

*AND WHEREAS the Year of the Garden 2022 will highlight and celebrate the important contribution of gardeners, the Magnetawan Horticultural Society, horticultural professionals and local horticultural businesses which contribute to garden culture and experience of our municipality;*

*AND WHEREAS gardens and gardening have helped us face the challenges of the COVID-19 pandemic;*

*NOW THEREFORE BE IT RESOLVED THAT the Council of the Municipality of Magnetawan hereby proclaims 2022 as the Year of the Garden!*

*Carried.*

#### **DEPUTATION**

##### **Chris Haist, Highland Road Culvert – Horn Lake**

*WHEREAS the Council of the Municipality of Magnetawan thanks Chris Haist and Tara Boyd, on behalf of the Horn Lake Cottage Association, for the deputation Highland Road Culvert – Horn Lake;*

*NOW THEREFORE BE IT RESOLVED THAT the Council of the Municipality of Magnetawan directs Staff to consider the comments made and prepare a report for Council with recommendations to be considered at a future meeting.*

*Carried.*

## **STAFF REPORTS, MOTIONS AND DISCUSSION**

### **2.1 Correspondence from Matt Foulk Ghost Gravel Cycling Event August 2022**

*RESOLUTION 2022-31 Hetherington-Smith*

*WHEREAS the Council of the Municipality receives the correspondence from Matt Foulk, Ghost Gravel Cycling Event revising the route for the 2022 Ghost Gravel Cycling Event approved by motion 2021-364;*

*AND WHEREAS the new route will follow Highway 124 from South river, to River Road, to Highway 520 back to Old Nipissing Road with the rest stop to be set up at the Magnetawan Centennial Park;*

*NOW THEREFORE BE IT RESOLVED that the Council of the Municipality of Magnetawan supports the Cycling event to be hosted on Saturday August 20, 2022 at no charge with the following conditions;*

- Approval from the Ontario Cycle Association is granted*
- No roads will be blocked and cyclists will not impede the flow of traffic*
- Insurance indemnifying the Municipality in the amount of \$5,000,000 is submitted to the Clerk prior to the event*
- The advertisements reflect that the rest stop is in Magnetawan, ON*
- All applicable COVID-19 guidelines must be followed*

*Carried.*

### **2.2 DRAFT Site Plan Agreement 390 Miller Road – Woodruff**

*RESOLUTION 2022-32 Smith-Kneller*

*BE IT RESOLVED THAT the Council of the Municipality of Magnetawan approves the DRAFT Site Plan Agreement 390 Miller Road – Woodruff and the by-law on this matter will be passed later in the meeting.*

*Carried.*

### **2.3 Correspondence from Jerry Brandt Almaguin Community Hatchery Program**

*\*Councillor John Hetherington declared a pecuniary interest for Agenda item 2.3 due to being a member of the Almaguin Community Hatchery Program. Councillor Hetherington left the Council Chambers and refrained from any discussion.*

*RESOLUTION 2022-33 Kneller-Smith*

*WHEREAS the Council of the Municipality of Magnetawan is appreciative of the important work that the Almaguin Community Hatchery has done and continues to do within the Municipality;*

*NOW THEREFORE BE IT RESOLVED that Council of the Municipality of Magnetawan authorizes the donation of \$500 to proceed with the educational component in the mobile hatchery.*

*Carried.*

## **MUNICIPAL BOARDS AND COMMITTEE MINUTES**

3.1 **OPP Almaguin Highlands 2020 Annual Progress Report**

3.2 **District of Parry Sound Social Services Administration Board (DSSAB) 2022 Budget**

*RESOLUTION 2022-34 Kneller-Hetherington*

*BE IT RESOLVED THAT the Council of the Municipality of Magnetawan receives the Municipal Boards and Committee Minutes as copied and circulated.*

*Carried.*

## **CORRESPONDENCE**

4.1 **Lakeland Holding Ltd. Memorandum 2021 Q4 Shareholder Update**

4.2 **Ministry of Infrastructure, Brining High-Speed Internet to Every Community**

4.3 **District of Parry Sound Social Services Administration Board (DSSAB) 2021 Board Member Honorariums and Expenses**

4.4 **Treasurer's Statement of 2021 Council Remuneration**

4.5 **Request for Tender 2022-01 Replacement of Culvert 11 Magnet Road and West Poverty Bay Road**

4.6 **Outcome of Canada Community Revitalization Fund Grant**

4.7 **Madd Message Appreciation Certificate**

4.8 **Magnetawan-Ahmic Harbour Netspectrum Rural Internet Tower**

4.9 **Fitness Classes Poster**

4.10 **ICYMI Council Highlights January 19, 2022**

*RESOLUTION 2022-35 Hetherington-Kneller*

*BE IT RESOLVED THAT the Council of the Municipality of Magnetawan receives the correspondence items as copied and circulated.*

*Carried.*

## **ACCOUNTS**

5.1 **Accounts in the amount of \$311,845.616**

*RESOLUTION 2022-36 Kneller-Smith*

*BE IT RESOLVED THAT the Council of the Municipality of Magnetawan approves the accounts in the amount of \$311,845.61 as presented.*

*Carried.*

## **BY-LAWS**

6.2 **Zoning By-law Amendment 390 Miller Road - Woodruff**

6.3 **Site Plan Agreement 390 Miller Road – Woodruff**

*RESOLUTION 2022-57 Smith-Kneller*

*BE IT RESOLVED THAT by the Council of the Municipality of Magnetawan that the following by-laws are now read a first, second and a third time, passed, signed by the Mayor and the Clerk, sealed with the seal of the Corporation, and engrossed in the by-law book:*

6.1 **Zoning By-law Amendment 390 Miller Road – Woodruff -**

6.2 **Site Plan Agreement 390 Miller Road – Woodruff**

*Carried.*

**CLOSED SESSION**

In accordance with Section 239(2) of the Municipal Act, 2001, S.O. 2001, c.25, as amended, Council shall proceed into Closed Session in order to address matters pertaining to:

- (b) personal matters about an identifiable individual
- (d) labour relations or employee negotiations
- (e) litigation or potential litigation

*RESOLUTION 2022-38 Kneller-Smith*

*BE IT RESOLVED THAT the Council of the Municipality of Magnetawan moves to a closed session at 1:35 pm pursuant to Section 239(2) of the Municipal Act, 2001, S.O. 2001, c.25, as amended, Council shall proceed into Closed Session in order to address matters pertaining to:*

- (b) personal matters about an identifiable individual*
- (d) labour relations or employee negotiations*
- (e) litigation or potential litigation*

*Carried.*

*RESOLUTION 2022-39 Kneller-Hetherington*

*BE IT RESOLVED THAT the Council of the Municipality of Magnetawan returns to open session at 2:25 pm.*

*Carried.*

**CONFIRMING BY-LAW AND ADJOURNMENT**

**7.1 Confirm the Proceedings of Council and Adjourn**

*RESOLUTION 2022-40 Kneller-Hetherington*

*BE IT RESOLVED by the Council of the Municipality of Magnetawan that the Confirming By-law is now read a first, second and a third time, passed, signed by the Mayor and the Clerk, sealed with the seal of the Corporation and engrossed in the by-law book;*

*AND FURTHER THAT, this meeting is now adjourned at 2:30 pm to meet again on Wednesday, March 02, 2022 at 1:00 pm at the call of the Chair.*

*Carried.*

Approved by:

\_\_\_\_\_  
Mayor

\_\_\_\_\_  
Clerk



**COUNCIL DEPUTATION REQUEST**

Any written submissions and background information for consideration by Council must be submitted to the Clerk's office at least 7 (seven) days prior to the set meeting date.

*PLEASE PRINT*

COUNCIL DATE REQUESTED: March 2nd or 23rd (subject to availability)

SUBJECT: Support to install, maintain and stock a community Food Pantry

NAME: Sylvia Poetschke (Rev)

ADDRESS: 165 South Street

Magnetawan

ON

PHONE: HOME: 613-331-1962 BUSINESS: 705-387-4939

EMAIL ADDRESS: sylvia.poetschke@yahoo.com

NAME OF GROUP OR PERSON(S) BEING REPRESENTED: (if applicable)

St. Paul's Lutheran Church and Trinity United Church

BRIEF STATEMENT OF ISSUE OR PURPOSE OF DEPUTATION (you may attach additional information)

Identified need: Local, emergency basic food and toiletries for the community experiencing need.

Plan: The 2 churches together with support from Knox would build, stock and maintain a "neighbourhood pantry"

This is to compliment ongoing support of Burks Falls Food Bank. Food and toiletries would be freely available.

Location to be determined (church property, or town property). Outcome: help meet basic needs via community donations.

Personal information on this form will be used for the purposes of sending correspondence relating to matters before Council. Your name, address, comments, and any other personal information, is collected and maintained for the purpose of creating a record that is available to the general public in a hard copy format and on the internet in an electronic format pursuant to Section 27 of the *Municipal Freedom of Information and Protection of Privacy Act*, R.S.O. 1990, c.M.56, as amended. Questions about this collection should be directed to the Clerk's office at [clerk@magnetawan.com](mailto:clerk@magnetawan.com) or 705 387 3947 x201

Submission of this form does not automatically guarantee you will be granted a deputation. The Clerk will notify you of the date and time for your deputation.



# Jelly Bean Row

## the First Two

Bloor By the Park Community Pantry



**Redeemer Lutheran**  
TORONTO, ONTARIO  
Finding *Life* in Community



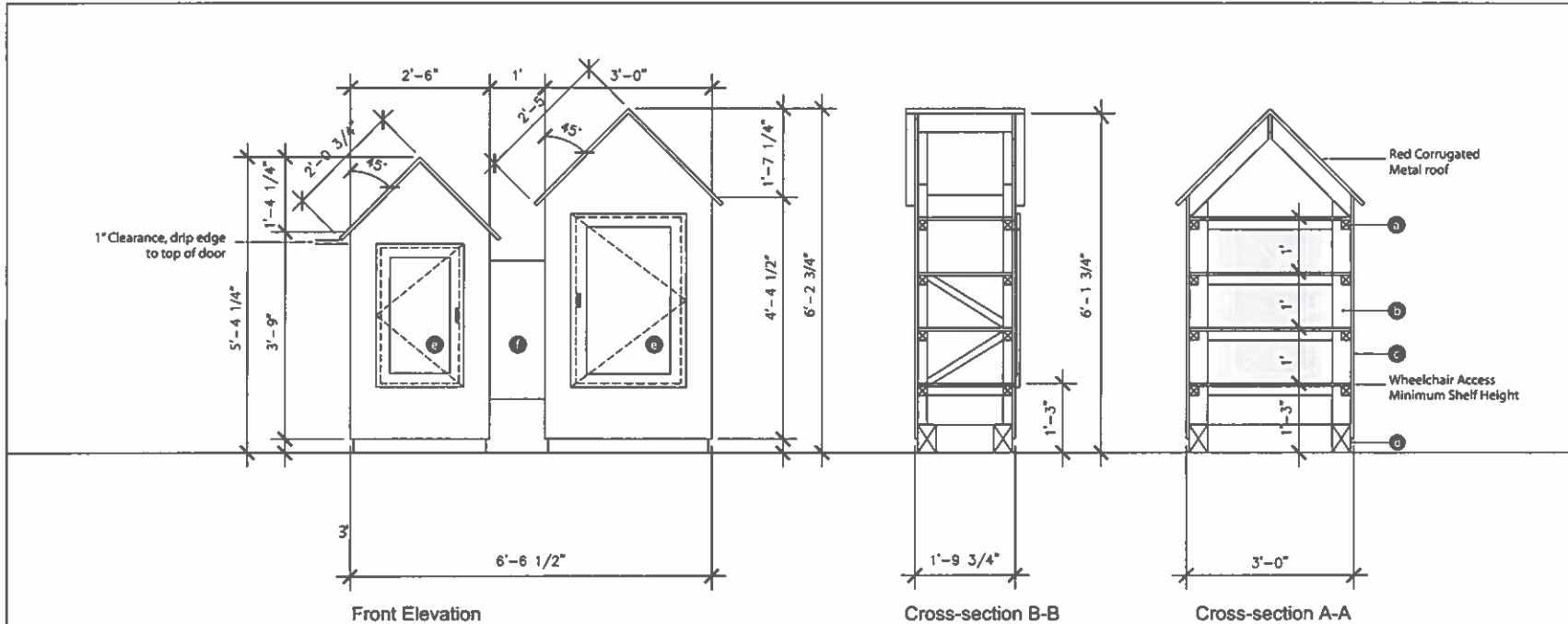

**LEGEND**  
 a - 2" x 2" framing  
 b - 2" x 4" framing  
 c - 3/4" plywood  
 d - 4' x 6" pressure treat  
 e - Door glazing, Lexan  
 f - 12" x 30" info graphic panel

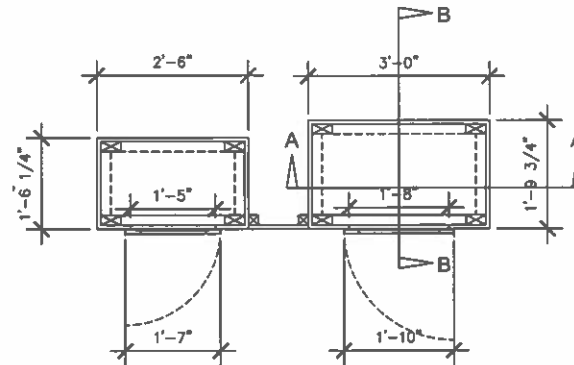

**NOTES**  
 Please refer to the last page of this PDF.

02	Issued for review	21.06.00
01	Issued for review	21.04.25
No.	Issued For	Date

Paul Backewich Architect  
 16 First Avenue  
 Toronto, ON  
 M4M 1W8  
 pbackewich@gmail.com  
 416-571-9210

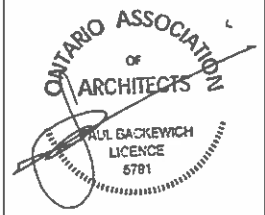

This drawing is the property of Paul Backewich Architect and may not be cited or reproduced without expressed approval.  
 Please refer to Engineering drawings before proceeding with work.  
 This, location, construction and material's handling of all structural elements are for illustrative purposes only, unless noted otherwise. Refer to documents by licensed structural engineer for all structural elements for this project.  
 The Contractor shall verify all levels and dimensions on site and report all discrepancies to the client and Paul Backewich Architect before suggesting work. Do not scale the drawings. The Contractor shall be responsible for any changes made to the drawings without Paul Backewich Architects approval.

**COMMUNITY PANTRY**  
 REDEEMER LUTHERAN TORONTO

Scale: As Shown Date: JUNE 08, 2021

Project No.: 21-04 Sheet No.: A-1.1



**Redeemer Lutheran**  
 TORONTO, ONTARIO  
 Finding Life in Community

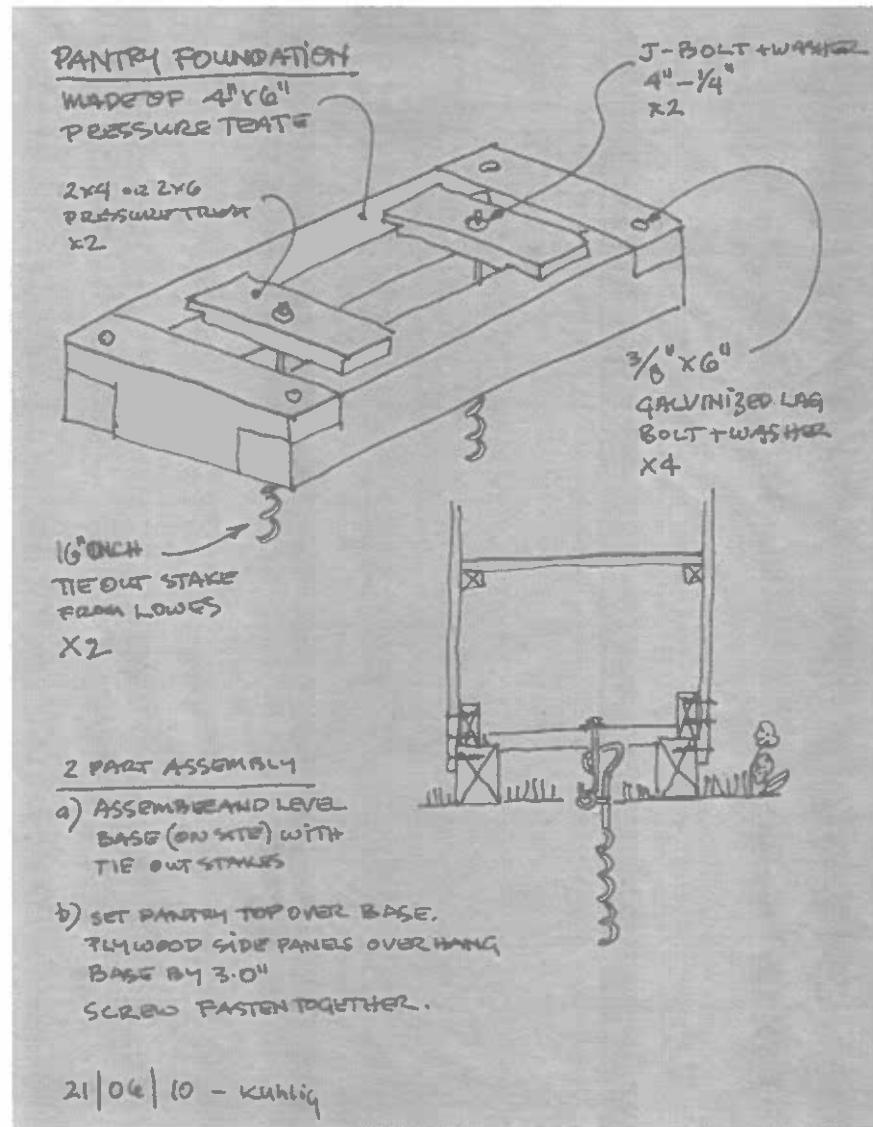

iPad 8:56 PM 100%  
**LOWE'S** TORONTO - YORK **Closed Now** Opens Thursday 7:00 AM  
 1-866-965-0937 FAQs CONTACT US  
 Change Stores Weekly Flyer Sign In

What can we help you find?

FREE PARCEL SHIPPING OVER \$49\* CURBSIDE PICKUP AVAILABLE PRICE MATCH PLUS 10% OUR COVID-19 RESPONSE

Products > Hardware > Chains, Ropes & Tie Downs > Chain Accessories

Blue Hawk

## 16-in Tie Out Stake

Item #: 348292 MFR #: 7517

★ ★ ★ ★ ★ 15 (1)  
Write a review



\$22.99

ADD TO CART

Feedback



**Free Store Pickup**

Available at  
**TORONTO - YORK**  
[Check Availability](#)



**Parcel Shipping**

May take up to 4-5 days to ship - shipments may be delayed by COVID-19



**Truck Delivery**

We'll call within 72 hours to schedule delivery

[Policies & Restrictions](#)

Free Parcel Shipping Over \$49  
[Shipping Policies](#)

iPad 8:04 PM 100%  
**RONA** RONA PIERREFONDS  
 Search by keyword ACCOUNT MY LIST MY CART FP

DEPARTMENTS DEALS & FLYER WORKSHOP INSTALLATION SERVICES OUTDOOR LIVING VIPPRO

Please note that due to a high volume of orders, there will be delays in processing orders. To check the Status of an order, click here

Home / Products / Hardware / Cables, Chains and Ropes / Chains and Wire Rope Accessories / J-Bolt With Hex Nut - 4" x 1/4" - Steel

Product selection from **ONWARD**

## J-Bolt With Hex Nut - 4" x 1/4" - Steel

Article #3504071 Item #000127357 Model #2133XBC Format 1/4"x4"

★★★★★ (1) [Write a review](#)

109  
each

ADD TO CART

Feedback



ADD TO WISH LIST

✓ **FREE PICK-UP IN STORE**

Ready within 48 hours\*

✓ **PARCEL SHIPPING**

Parcel shipped within 1-2 business days\*

✓ **RONA TRUCK DELIVERY**

Delivered in 7-14 days\*\*

Curbside pickup is available at participating stores [Details](#)

RONA Pierrefonds (514) 624-2333

## NOTES

1. We'd like to make two pantries.
  - a) The smaller as presented with a 30" x 18" footprint for Dry Goods. (Single door hinges on left?)
  - b) The larger is about 20% bigger with an ~36" x 213/4" footprint and the height scaled —more or less—proportionately to the smaller one for Canned Goods.
2. Infographic panel is 12" x 30". See photo, mounted between to pantries.
3. For ease of access the cupboard openings should be as wide as possible
4. Peaks will be used to identify the community pantry with a touch of branding.
5. No opening for empty plastic bags
6. Door glazing – Lexan?
7. 3.0"± roof overhang front & back with proportional on left and right sides
8. Can the roof be red metal/steel
9. The doors of each pantry should clear the drip edge of the roof
10. For cooling/ventilation, please add a vent at the back of each
11. For wheelchair access, the lower shelf should be 15.0" off the ground
12. The spaces between shelves for the smaller pantry, should be between 10" to 12" to accommodate 2-28 ounce cans stacked (~ 9¼").
13. Bass could be made of 4 x 6 pressure treated lumber
14. Each pantry should be screwed together (No nails).
15. Shelving needs to be screwed down to prevent their nefarious removal.
16. For ease of cleaning the interior, we should spray it white.
17. A panel on each unit should be easily removable for access to peak/roof area to install future solar LED lighting or 12Volt electrification.
18. Colours – the smaller pantry will be yellow (close to Pantone 107) with a white door. The larger pantry will be orange/tangerine (close to Pantone 716) with white doors. Both colours are drawn from Redeemer's logo.
20. How might we light with Solar or 12v LED equivalent?

 <p data-bbox="233 321 492 405"><b>Municipality of Magnetawan</b></p>	<p data-bbox="777 243 1182 279"><b>REPORT TO COUNCIL</b></p>
<p data-bbox="191 415 248 447">To:</p>	<p data-bbox="557 415 846 453">Mayor and Council</p>
<p data-bbox="191 464 285 495">From:</p>	<p data-bbox="557 464 932 495">Joe Readman, Fire Chief</p>
<p data-bbox="191 506 448 537">Date of Meeting:</p>	<p data-bbox="557 506 776 537">March 2, 2022</p>
<p data-bbox="191 550 386 581">Report Title:</p>	<p data-bbox="557 550 1401 581">Update to FPPA/Mandatory Certification for firefighters</p>

**Recommendation:** THAT Council receives and approves this report as presented.

**Background:** In 2018 the Government of Ontario created and tried to enact a mandatory certification Regulation for all municipal and unorganized fire departments within the province, based around the National Fire Protection Association (NFPA). It was quickly identified by Fire Chiefs and Municipal Councils that this Regulation was unachievable in the timelines provided. The regulation was revoked later that year, with a clear message this Regulation would return.

The Minister of the Solicitor General currently is proposing a new mandatory certification model, this time with participation from the Ontario Association of Fire Chiefs in its creation. This Regulation allows a department to review their own Establishing and Regulating bylaw and only certify to the level of service Council has approved through that bylaw. This Regulation was out for public comment until February 28, 2022.

This Regulation will be an addition to the Fire Prevention and Protection Act 1997.

**Financial Implication:** With the success of our Regional Training Officer agreement and program, this new regulation will have no additional costs. Magnetawan Fire fully anticipated and prepared for the return of certification and has actively been training to the NFPA Standard.

**Conclusion:** After reviewing the new Regulation I feel we will have no issue meeting the minimum levels of certification by the dates outlined.

Respectfully Submitted,

*Joe Readman*

Joe Readman,  
Fire Chief.

**Caution:**

*This consultation draft is intended to facilitate dialogue concerning its contents. Should the decision be made to proceed with the proposal, the comments received during consultation will be considered during the final preparation of the regulation. The content, structure, form and wording of the consultation draft are subject to change as a result of the consultation process and as a result of review, editing and correction by the Office of Legislative Counsel.*

**CONSULTATION DRAFT**

**ONTARIO REGULATION**

to be made under the

**FIRE PROTECTION AND PREVENTION ACT, 1997**

**FIREFIGHTER CERTIFICATION**

**CONTENTS**

<u>1.</u>	Definition
<u>2.</u>	Mandatory certification
<u>3.</u>	Exceptions
<u>4.</u>	Transition
<u>5.</u>	Commencement
<u>Table 1</u>	Mandatory certification for fire protection services

**Definition**

1. In this Regulation,

“NFPA” means the National Fire Protection Association.

**Mandatory certification**

2. (1) Every municipality, and every fire department in a territory without municipal organization, must ensure that its firefighters perform a fire protection service set out in Column 1 of Table 1 only if, on or after the corresponding day specified in Column 3 of that Table,

- (a) the firefighter performing the fire protection service is certified, at a minimum, to the corresponding certification standard set out in Column 2 of that Table; or



(b) this Regulation provides that the certification standard referred to in clause (a) does not apply with respect to the firefighter.

(2) The certification must be,

(a) provided by the Fire Marshal; or

(b) an accreditation from the International Fire Safety Accreditation Congress (IFSAC), or a Pro Board seal, that is recognized by the Fire Marshal as equivalent to the certification provided by the Fire Marshal.

### **Exceptions**

3. (1) A certification standard set out in item 1 or 2 of Table 1 does not apply with respect to a firefighter who,

(a) is performing a service that is within the scope of that item;

(b) has been a firefighter for no more than 24 months; and

(c) is operating under the supervision of a firefighter certified to that standard.

(2) A certification standard set out in Column 2 of Table 1 does not apply with respect to a firefighter who is,

(a) temporarily assigned to perform a different fire protection service for which a different minimum certification is required; and

(b) operating under the supervision of a firefighter who has obtained the certification corresponding to the fire protection service or services being delivered.

(3) If a firefighter was previously certified under this Regulation for an item listed in Table 1, that certification continues to be valid even if the requirements for obtaining that certification are subsequently updated or changed.

## Transition

4. (1) Subject to subsection (2), a certification standard set out in item 1, 2, 3, 5, 6, 7, 9, 10, 11, 12, 13, 14, 15, 17 or 18 of Table 1 does not apply with respect to a firefighter if the Fire Marshal issues the firefighter a letter of compliance with the certification standard in accordance with this section.

(2) The Fire Marshal shall issue a letter of compliance with a certification standard to a firefighter if,

- (a) the firefighter has been performing the fire protection service that the standard corresponds to since at least,
  - (i) January 1, 2021, in the case of a certification standard set out in item 1, 2, 3, 5, 6 or 7,
  - (ii) January 1, 2020, in the case of a certification standard set out in item 9, 10, 11, 12, 13, 14 or 15, or
  - (iii) January 1, 2019, in the case of a certification standard set out in item 17 or 18;
- (b) before September 30, 2023, the firefighter's municipality, or fire department in an area without municipal organization, provides the Fire Marshal with information, such as training records, to demonstrate to the satisfaction of the Fire Marshal that the firefighter, through past training and experience, has obtained the requisite knowledge and requisite skills associated with the corresponding standard; and
- (c) the Fire Marshal is satisfied with the information provided under clause (b).

## Commencement

### 5. [Commencement]

TABLE 1  
MANDATORY CERTIFICATION FOR FIRE PROTECTION SERVICES

Item	Column 1 Fire protection service	Column 2 Minimum Certification Standard	Column 3 Compliance Deadline
1.	Firefighter Exterior Attack: Fire suppression operations from the exterior of the building only.	The following job performance requirements of NFPA 1001, "Standard for Fire Fighter Professional Qualifications", 2019 Edition, Chapter 4 (Firefighter I) and Chapter 5 (Firefighter II):	July 1, 2026

		4.1, 4.2, 4.3.1, 4.3.2, 4.3.3, 4.3.6, 4.3.7, 4.3.8, 4.3.10 (A1-A9, B1-B3, B4 (exterior stairway), B5-B10), 4.3.15, 4.3.16, 4.3.17, 4.3.18, 4.3.19, 4.3.20, 4.3.21, 4.5  5.1, 5.2, 5.3.1, 5.3.2 (A1-A4), 5.3.3, 5.3.4, 5.4.2, 5.5.3	
2.	Firefighter Exterior Attack and auto extrication: Fire suppression operations from the exterior of the building only and auto extrication rescue.	All job performance requirements in Item 1 and the following job performance requirements of NFPA 1001, "Standard for Fire Fighter Professional Qualifications", 2019 Edition, Chapter 5 (Firefighter II):  5.4.1	July 1, 2026
3.	Firefighter Exterior Attack and hazardous materials response: Fire suppression operations from the exterior of the building only and Operations-level hazardous materials response.	All job performance requirements in Item 1 and all job performance requirements of NFPA 1072, "Standard for Hazardous Materials/Weapons of Mass Destruction Emergency Response Personnel Professional Qualifications", 2017 Edition, Chapter 5 (Operations).	July 1, 2026
4.	Firefighter Exterior Attack, auto extrication and hazardous materials response: Fire suppression operations from the exterior of the building only, automobile extrication rescue and Operations-level hazardous materials response.	All job performance requirements in Items 1, 2 and 3.	July 1, 2026
5.	Firefighter Interior Attack: Fire suppression operations that enter the interior of the building and can perform rescue.	All job performance requirements in Item 1 and the following job performance requirements of NFPA 1001, "Standard for Fire Fighter Professional Qualifications", 2019 Edition, Chapter 4 (Firefighter I) and Chapter 5 (Firefighter II):  4.3.4, 4.3.9, 4.3.10 (A10-A11, B4 (interior stairway), B11), 4.3.11, 4.3.12, 4.3.13, 4.3.14  5.3.2 (A5-A9, B1-B6)	July 1, 2026
6.	Firefighter Interior Attack and auto extrication: Fire suppression operations that enter the interior of the building and can perform rescue and automobile extrication rescue.	All job performance requirements in Item 5 and the following job performance requirements of NFPA 1001, "Standard for Fire Fighter Professional Qualifications", 2019 Edition, Chapter 5 (Firefighter II):  5.4.1	July 1, 2026
7.	Firefighter Interior Attack and hazardous materials response: Fire suppression operations that enter the interior of the building and Operations-level hazardous materials response.	All job performance requirements in Item 5 and all job performance requirements of NFPA 1072, "Standard for Hazardous Materials/Weapons of Mass Destruction Emergency Response Personnel Professional Qualifications", Chapter 5 (Operations).	July 1, 2026
8.	Firefighter Interior Attack, auto extrication and hazardous materials response: Fire suppression operations that enter the interior of the building and can perform rescue, automobile extrication rescue and Operations-level hazardous materials response (full service firefighter).	All job performance requirements of NFPA 1001, "Standard for Fire Fighter Professional Qualifications", 2019 Edition, Chapter 5 (Firefighter II).	July 1, 2026
9.	Team Lead Exterior Attack: Supervision of firefighters that provide fire suppression operations from the exterior of the building only.	All job performance requirements in Item 1 and the following job performance requirements of NFPA 1021, "Standard for Fire Officer Professional Qualifications", 2014 Edition, Chapter 4 (Fire Officer I):  4.1.1, 4.2.1, 4.2.2, 4.2.3, 4.2.4, 4.4.1, 4.4.2,	July 1, 2026

		4.4.4, 4.4.5, 4.5.3, 4.6, 4.7.1, 4.7.3	
10.	Team Lead Exterior Attack and auto extrication: Supervision of firefighters that provide fire suppression operations from the exterior of the building only or that provide auto extrication rescue.	All job performance requirements in Item 2 and the following job performance requirements of NFPA 1021, "Standard for Fire Officer Professional Qualifications", 2014 Edition, Chapter 4 (Fire Officer I):  4.1.1, 4.2.1, 4.2.2, 4.2.3, 4.2.4, 4.4.1, 4.4.2, 4.4.4, 4.4.5, 4.5.3, 4.6, 4.7.1, 4.7.3	July 1, 2026
11.	Team Lead Exterior Attack and hazardous materials response: Supervision of firefighters that provide fire suppression operations from the exterior of the building only or that provide Operations-level hazardous materials response.	All job performance requirements in Item 3 and the following job performance requirements of NFPA 1021, "Standard for Fire Officer Professional Qualifications", 2014 Edition, Chapter 4 (Fire Officer I):  4.1.1, 4.2.1, 4.2.2, 4.2.3, 4.2.4, 4.4.1, 4.4.2, 4.4.4, 4.4.5, 4.5.3, 4.6, 4.7.1, 4.7.3	July 1, 2026
12.	Team Lead Exterior Attack, auto extrication and hazardous materials: Supervision of firefighters that provide fire suppression operations from the exterior of the building only or that provide automobile extrication rescue or Operations-level hazardous materials response.	All job performance requirements in Item 4, and the following job performance requirements of NFPA 1021, "Standard for Fire Officer Professional Qualifications", 2014 Edition, Chapter 4 (Fire Officer I):  4.1.1, 4.2.1, 4.2.2, 4.2.3, 4.2.4, 4.4.1, 4.4.2, 4.4.4, 4.4.5, 4.5.3, 4.6, 4.7.1, 4.7.3	July 1, 2026
13.	Team Lead Interior Attack: Supervision of firefighters that provide fire suppression operations from the interior of the building and can perform rescue.	All job performance requirements in Item 5 and the following job performance requirements of NFPA 1021, "Standard for Fire Officer Professional Qualifications", 2014 Edition, Chapter 4 (Fire Officer I):  4.1.1, 4.2.1, 4.2.2, 4.2.3, 4.2.4, 4.4.1, 4.4.2, 4.4.4, 4.4.5, 4.5.3, 4.6, 4.7.1, 4.7.3	July 1, 2026
14.	Team Lead Interior Attack and auto extrication: Supervision of firefighters that provide fire suppression operations from the interior of the building and can perform rescue or that provide automobile extrication rescue.	All job performance requirements in Item 6 and the following job performance requirements of NFPA 1021, "Standard for Fire Officer Professional Qualifications", 2014 Edition, Chapter 4 (Fire Officer I):  4.1.1, 4.2.1, 4.2.2, 4.2.3, 4.2.4, 4.4.1, 4.4.2, 4.4.4, 4.4.5, 4.5.3, 4.6, 4.7.1, 4.7.3	July 1, 2026
15.	Team Lead Interior Attack and hazardous materials response: Supervision of firefighters that provide fire suppression operations from the interior of the building and can perform rescue or that provide Operations-level hazardous materials response.	All job performance requirements in Item 7 and the following job performance requirements of NFPA 1021, "Standard for Fire Officer Professional Qualifications", 2014 Edition, Chapter 4 (Fire Officer I):  4.1.1, 4.2.1, 4.2.2, 4.2.3, 4.2.4, 4.4.1, 4.4.2, 4.4.4, 4.4.5, 4.5.3, 4.6, 4.7.1, 4.7.3	July 1, 2026
16.	Team Lead Interior Attack, auto extrication and hazardous materials response: Supervision of firefighters that provide fire suppression operations from the interior of the building and can perform rescue or that provide automobile extrication rescue or Operations-level hazardous materials response (full service fire officer).	All job performance requirements of NFPA 1021 "Standard for Fire Officer Professional Qualifications", 2014 Edition, Chapter 4 (Fire Officer I).	July 1, 2026
17.	Pump Operations: Operation of a pumper apparatus without driving the apparatus, or where the apparatus does not require a class D licence.	All job performance requirements of NFPA 1002, "Standard for Fire Apparatus Driver/Operator Professional Qualifications", 2017 Edition, Chapter 5 (Apparatus Equipped with Fire Pump), without pre-requisites in Chapter 4.	July 1, 2026

18.	Pump Operations: driver: Driving and operating a pumper apparatus that requires a class D licence.	All job performance requirements in NFPA 1002 “Standard for Fire Apparatus Driver/Operator Professional Qualifications”, 2017 Edition, Chapter 5 (Apparatus Equipped with Fire Pump).	July 1, 2026
19.	Fire Prevention/Inspection: conducting fire and life safety inspections.	All job performance requirements of NFPA 1031, “Standard for Professional Qualifications for Fire Inspector and Plan Examiner”, 2014 Edition, Chapter 4 (Fire Inspector I).	July 1, 2026
20.	Fire Investigator: conducting fire cause and origin investigations.	All job performance requirements of NFPA 1033, “Professional Qualifications for Fire Investigator”, 2014 Edition, Chapter 4 (Fire Investigator).	July 1, 2026
21.	Fire and Life Safety Educator: providing fire and life safety education.	All job performance requirements of NFPA 1035, “Standard on Fire and Life Safety Educator, Public Information Officer, Youth Firesetter Intervention Specialist, and Youth Firesetter Program Manager Professional Qualifications”, 2015 Edition, Chapter 4 (Fire and Life Safety Educator).	July 1, 2026
22.	Training Officer: providing training and education to other fire personnel.	All job performance requirements of NFPA 1041, “Standard for Fire and Emergency Services Instructor Professional Qualifications”, 2019 Edition, Chapter 4 (Fire and Emergency Services Instructor I).	July 1, 2026
23.	Emergency Communicators: taking emergency calls.	All job performance requirements of NFPA 1061, “Standard for Public Safety Telecommunications Personnel Professional Qualifications”, 2018 Edition, Chapter 4 (Public Safety Telecommunicator I).	July 1, 2026
24.	Incident Safety Officers: undertaking the primary role of incident safety officer at emergency calls.	All job performance requirements of NFPA 1521, “Standard for Fire Department Safety Officer Professional Qualifications”, 2020 Edition, Chapter 5 (Incident Safety Officer).	July 1, 2026
25.	Hazardous Materials Response — Operations Mission Specific Level: responding to emergencies involving hazardous materials at the Operations Mission Specific Level.	All job performance requirements of NFPA 1072, “Standard for Hazardous Materials/Weapons of Mass Destruction Emergency Response Personnel Professional Qualifications”, Chapter 6 (Operations Mission Specific)	July 1, 2026
26.	Hazardous Materials Response — Technician Level: responding to emergencies involving hazardous materials at the Technician Level.	All job performance requirements of NFPA 1072, “Standard for Hazardous Materials/Weapons of Mass Destruction Emergency Response Personnel Professional Qualifications” Chapter 7 (Hazardous Materials Technician).	July 1, 2026
27.	Rope Rescue — Operations: rope rescue at the Operations Level.	The following job performance requirements of NFPA 1006, “Standard for Technical Rescue Personnel Professional Qualifications”, 2021 Edition, Chapter 5 (Rope Rescue) (Operations): 5.2	July 1, 2028
28.	Rope Rescue — Technician: rope rescue at the Technician Level.	The following job performance requirements of NFPA 1006, “Standard for Technical Rescue Personnel Professional Qualifications”, 2021 Edition, Chapter 5 (Rope Rescue) (Technician): 5.3	July 1, 2028
29.	Structural Collapse — Operations: structural collapse rescue at the Operations Level.	The following job performance requirements of NFPA 1006, “Standard for Technical Rescue Personnel Professional Qualifications”, 2021	July 1, 2028

		Edition, Chapter 6 (Structural Collapse Rescue) (Operations): 6.2	
30.	Structural Collapse — Technician: structural collapse rescue at the Technician Level.	The following job performance requirements of NFPA 1006, “Standard for Technical Rescue Personnel Professional Qualifications”, 2021 Edition, Chapter 6 (Structural Collapse Rescue) (Technician): 6.3	July 1, 2028
31.	Confined Space — Operations: confined space rescue at the Operations Level.	The following job performance requirements of NFPA 1006, “Standard for Technical Rescue Personnel Professional Qualifications”, 2021 Edition, Chapter 7 (Confined Space Rescue) (Operations): 7.2	July 1, 2028
32.	Confined Space — Technician: confined space rescue at the Technician Level.	The following job performance requirements of NFPA 1006, “Standard for Technical Rescue Personnel Professional Qualifications”, 2021 Edition, Chapter 7 (Confined Space Rescue) (Technician): 7.3	July 1, 2028
33.	Vehicle Rescue — Operations: rescue involving passenger vehicles at the Operations Level.	The following job performance requirements of NFPA 1006, “Standard for Technical Rescue Personnel Professional Qualifications”, 2021 Edition, Chapter 8 (Common Passenger Vehicle Rescue) (Operations): 8.2	July 1, 2028
34.	Vehicle Rescue — Technician: rescue involving passenger vehicles at the Technician Level.	The following job performance requirements of NFPA 1006, “Standard for Technical Rescue Personnel Professional Qualifications”, 2021 Edition, Chapter 8 (Common Passenger Vehicle Rescue) (Technician): All of 8.3	July 1, 2028
35.	Heavy Vehicle Rescue — Operations: rescue involving heavy vehicles at the Operations Level.	The following job performance requirements of NFPA 1006, “Standard for Technical Rescue Personnel Professional Qualifications”, 2021 Edition, Chapter 9 (Heavy Vehicle Rescue) (Operations): 9.2	July 1, 2028
36.	Heavy Vehicle Rescue — Technician: rescue involving heavy vehicles at the Technician Level.	The following job performance requirements of NFPA 1006, “Standard for Technical Rescue Personnel Professional Qualifications”, 2021 Edition, Chapter 9 (Heavy Vehicle Rescue) (Technician): 9.3	July 1, 2028
37.	Trench Rescue — Operations: trench rescue at the Operations Level.	The following job performance requirements of NFPA 1006, “Standard for Technical Rescue Personnel Professional Qualifications”, 2021 Edition, Chapter 12 (Trench Rescue) (Operations): 12.2	July 1, 2028
38.	Trench Rescue — Technician: trench rescue at the Technician Level.	The following job performance requirements of NFPA 1006, “Standard for Technical Rescue Personnel Professional Qualifications”, 2021	July 1, 2028

		Edition, Chapter 12 (Trench Rescue) (Technician):  12.3	
39.	Surface Water Rescue — Operations: surface water rescue at the Operations Level.	The following job performance requirements of NFPA 1006, "Standard for Technical Rescue Personnel Professional Qualifications", 2021 Edition, Chapter 17 (Surface Water Rescue) (Operations):  17.2	July 1, 2028
40.	Surface Water Rescue — Technician: surface water rescue at the Technician Level.	The following job performance requirements of NFPA 1006, "Standard for Technical Rescue Personnel Professional Qualifications", 2021 Edition, Chapter 17 (Surface Water Rescue) (Technician):  17.3	July 1, 2028
41.	Swift Water Rescue — Operations: swift water rescue at the Operations Level.	The following job performance requirements of NFPA 1006, "Standard for Technical Rescue Personnel Professional Qualifications", 2021 Edition, Chapter 18 (Swiftwater Rescue) (Operations):  18.2	July 1, 2028
42.	Swift Water Rescue — Technician: swift water rescue at the Technician Level.	The following job performance requirements of NFPA 1006, "Standard for Technical Rescue Personnel Professional Qualifications", 2021 Edition, Chapter 18 (Swiftwater Rescue) (Technician):  18.3	July 1, 2028
43.	Ice Water Rescue — Operations: ice water rescue at the Operations Level.	The following job performance requirements of NFPA 1006, "Standard for Technical Rescue Personnel Professional Qualifications", 2021 Edition, Chapter 20 (Ice Rescue) (Operations):  20.2	July 1, 2028
44.	Ice Water Rescue — Technician: ice water rescue at the Technician Level.	The following job performance requirements of NFPA 1006, "Standard for Technical Rescue Personnel Professional Qualifications", 2021 Edition, Chapter 20 (Ice Rescue) (Technician):  20.3	July 1, 2028

# Proposed Firefighter Certification Regulation

Presented to: Municipal Representatives

Date: February 18, 2022



# Purpose

1. To provide an overview of the proposed Firefighter Certification regulation, which is currently available for review and comment on the [Ontario Regulatory Registry](#) until February 28, 2022; and,
2. To address questions related to the proposed regulation.

# Firefighter Training and Certification: Current State

- The *Fire Protection and Prevention Act, 1997* (FPPA) does not set minimum standards for firefighter training and certification (See Appendix A). Municipalities, as the employer, are required to provide information, instruction and supervision to protect the health and safety of workers under Section 25(2)(a) of the *Occupational Health and Safety Act, 1990*.
  - **Ontario Regulation 379/18: Firefighter Certification**, which established mandatory National Fire Protection Association (NFPA) certification requirements for firefighters in ten specific roles, was revoked in 2018 prior to coming into force.
- Training practices vary across fire departments in municipalities and territories without municipal organization in Ontario.
- Ontario provides certification testing for 45 National Fire Protection Association (NFPA) levels of certification and is accredited through the International Fire Service Accreditation Congress (IFSAC) and the Pro Board.
- There is a lack of flexibility in NFPA testing practices.
  - Prerequisites under the current model do not allow for flexibility or customization of training to local needs and service levels, resulting in training pressures on volunteer fire services.

**Goal:** To develop a standardized approach to firefighter training, which **protects firefighters and increases public safety** while providing flexibility for the local needs and service levels of municipalities across Ontario.



# Key Considerations for Firefighter Certification



## Protecting the Health and Safety of Firefighters

In the absence of provincial regulations specific to firefighters, they might not have the appropriate level of training to meet risks associated with service levels established in their municipality.



## Level of Service

Stakeholders have raised concerns about minimum standards that would require training beyond the level of service being delivered, as well as exposure to liability if all firefighters are not certified to the minimum standard.



## Addressing Legacy Provisions

Proposal would enable current fire service personnel to be certified to their current level and consider any time required for municipalities to adhere to the regulation.



## Modernization of Firefighter Training

Proposal would create opportunities to better support training delivery and certification including the option to certify firefighters to higher standards.

# Overview of the Proposed Regulation

The Ministry of the Solicitor General is proposing to file a regulation under the FPPA to establish mandatory certification requirements for fire protection services.

Mandatory Certification	Exceptions	Transition (Legacy Provisions)
<ul style="list-style-type: none"> <li>▪ Municipalities would ensure that a firefighter is certified to the prescribed NFPA job performance requirements to perform certain fire protection services (e.g., firefighter exterior attack).               <ul style="list-style-type: none"> <li>○ The certification must be provided by the Fire Marshal, or an accreditation from the International Fire Safety Accreditation Congress (IFSAC) or a Pro Board seal for full NFPA standards.</li> <li>○ The prescribed compliance deadline for most fire protection services is July 1, 2026 (e.g., firefighter exterior attack) and July 1, 2028 for technical rescue services (e.g., rope rescue operations).</li> </ul> </li> </ul>	<ul style="list-style-type: none"> <li>▪ There are proposed exceptions for new firefighters (&lt; 24 months) who are operating under the supervision of a firefighter certified to the required standard for a prescribed fire protection service as well as for firefighters who are temporarily assigned to perform a different fire protection service and are operating under the supervision of a firefighter certified to the standard for that service.</li> <li>▪ Firefighters would not be required to automatically re-certify if the corresponding certification requirements are subsequently updated or changed.</li> </ul>	<ul style="list-style-type: none"> <li>▪ There would be a time-limited opportunity (until September 30, 2023) for fire departments to apply for a letter of compliance based on existing firefighters' previously completed training and existing skills and knowledge.               <ul style="list-style-type: none"> <li>○ This process would only be available for fire protection services that do not require full NFPA certification and to firefighters who have been providing those services for a minimum number of years (2-4 years, depending on the service).</li> <li>○ The Office of the Fire Marshal would set out the required information for fire departments to submit.</li> </ul> </li> </ul>

# Overview of the Proposed Approach

Level of Training	NFPA Standard	Minimum Level for Full-Service Departments	Additional Level Available via OFM ASE	Ontario-Specific Standard	
Firefighter	NFPA 1001	Level II	N/A	Exterior Firefighter	Interior Firefighter
Fire Officer	NFPA 1021	Level I	Level II, III and IV	Team Lead – Exterior	Team Lead - Interior
Pump Operators	NFPA 1002	Chapter 5	N/A	Pump Operator	
Hazardous Materials	NFPA 1072	Operations	Awareness, Technician and Mission Specific	Haz Mat Operations added to Exterior/Interior	
Auto Extrication	For Ontario-Specific Standard Only			Auto Ex (FFII JPRs) added to Exterior/Interior	
Senior Fire Officer	Optional Certification (not in Regulation)			Senior Fire Officer I	Senior Fire Officer II
Level of Training	NFPA Standard	Minimum Level	Additional Level Available via OFM ASE	Notes	
Fire Inspector	NFPA 1031	Level I	Level II and III	<p>For Section 2 - Fire Department must certify staff that work in these roles on a regular/expected basis (e.g. normal job assignment) to the minimum level AND increase to additional levels based on job roles and responsibilities. For Example:</p> <p>Live Fire requires lead instructor to be trained to NFPA 1041 Level II  Inspections of Flammable/Combustible liquids properties requires NFPA 1031 Level II  Calltaker/Dispatcher requires NFPA 1061 Level II</p>	
Fire Investigator	NFPA 1033	Chapter 4	N/A		
Fire Life Safety Educator	NFPA 1035	Educator I	Educator II and PIO		
Training Officer	NFPA 1041	Level I	Level II and III		
Emergency Communicators	NFPA 1061	Level I	Level II		
Incident Safety Officer	NFPA 1521	Chapter 5	N/A		

# Overview of the Proposed Approach, cont.

Level of Training	NFPA Standard	Minimum Level		Additional Level Available via OFM ASE	Section 3 Notes
Common Passenger Vehicle Rescue	NFPA 1006	Awareness	Training only, not required to Certify (see Section 3 Note)	Operations and Technician	<p><b>For Section 3 – Any Fire Department that expects to respond to any technical rescue emergency calls should train their firefighters to minimum of Awareness Level (however, they do not have to certify via ASE).</b></p> <p>Additionally, any firefighters that operate at a higher level at these calls would be required to be <b>certified</b> to the applicable level (operations or technician based on response levels)</p> <p><b>This includes NFPA 1072 – Haz Mat as well (although it is listed in Section 1 for clarity)</b></p>
Heavy Vehicle Rescue	NFPA 1006	Awareness		Operations and Technician	
Surface Water	NFPA 1006	Awareness		Operations and Technician	
Swift Water	NFPA 1006	Awareness		Operations and Technician	
Ice Water	NFPA 1006	Awareness		Operations and Technician	
Trench Rescue	NFPA 1006	Awareness		Operations and Technician	
Confined Space	NFPA 1006	Awareness		Operations and Technician	
Structural Collapse	NFPA 1006	Awareness		Operations and Technician	
Rope Rescue	NFPA 1006	Awareness		Operations and Technician	

# Implementation Considerations

Input from municipal and fire safety stakeholders (see Appendix B) informed the proposed regulation, including the implementation considerations.

Flexibility	Training
<ul style="list-style-type: none"><li>▪ The proposed approach would provide flexibility to meet local training needs based on the level of fire protection service set by municipal council.</li><li>▪ If the local level of service exceeds the minimum standard set out in the proposed regulation, the Office of the Fire Marshal would continue to provide certification to full NFPA standards at <b>no cost</b>.</li><li>▪ Municipalities that require assistance in reviewing their Establishing and Regulating bylaw and level of service are encouraged to contact their Fire Protection Adviser at the Office of the Fire Marshal.</li></ul>	<ul style="list-style-type: none"><li>▪ Many fire departments already train to a higher standard than the proposed minimum certification requirements.</li><li>▪ Fire departments would continue to train according to the local level of fire protection service.</li></ul>

# Implementation Considerations, cont.

Compliance	Administration
<ul style="list-style-type: none"> <li>▪ Staggered timelines are proposed to help ensure fire departments have sufficient time to:               <ul style="list-style-type: none"> <li>○ Certify new firefighters (2026 for most fire protection services; 2028 for technical rescue).</li> <li>○ Submit “legacy” applications for eligible firefighters (would be able to apply until September 2023).</li> </ul> </li> <li>▪ To meet the new requirements in the proposed regulation, municipalities and their fire departments are encouraged to plan out the next four to six years of training.</li> <li>▪ The FM has the power to monitor, review and advise municipalities respecting the provision of fire protection services. This includes designated OFM sections monitoring/reviewing the requirements of minimum certification.</li> <li>▪ The OFM would take a phased approach to enforcement:               <ul style="list-style-type: none"> <li>○ Review concerns with the Fire Chief,</li> <li>○ Address concerns with the CAO,</li> <li>○ Failing the above points, the FM would consider additional options to communicate to the public.</li> </ul> </li> <li>▪ The Fire Marshal reserves the right to:               <ul style="list-style-type: none"> <li>○ Use enforcement measures available under the FPPA</li> <li>○ Refer the issue to the MLTSD given the potential impact to firefighter health and safety</li> </ul> </li> </ul>	<ul style="list-style-type: none"> <li>▪ Some administrative costs are estimated based on the potential value of time it may take municipal fire departments to:               <ul style="list-style-type: none"> <li>○ Familiarize themselves with the regulation.</li> <li>○ Maintain training records.</li> <li>○ Complete one-time legacy applications (estimated one hour per application).</li> </ul> </li> <li>▪ The estimated range (between \$290 to \$1400 per fire department) would depend on the size of the department and number of legacy applications for eligible firefighters.               <ul style="list-style-type: none"> <li>○ This estimated cost range does not capture any associated training costs which are expected to be minimal as most fire departments are anticipated to already be training to the service level established by their municipality.</li> </ul> </li> </ul>

The Office of the Fire Marshal is developing resources to support implementation.





# Timeline for Proposed Regulation

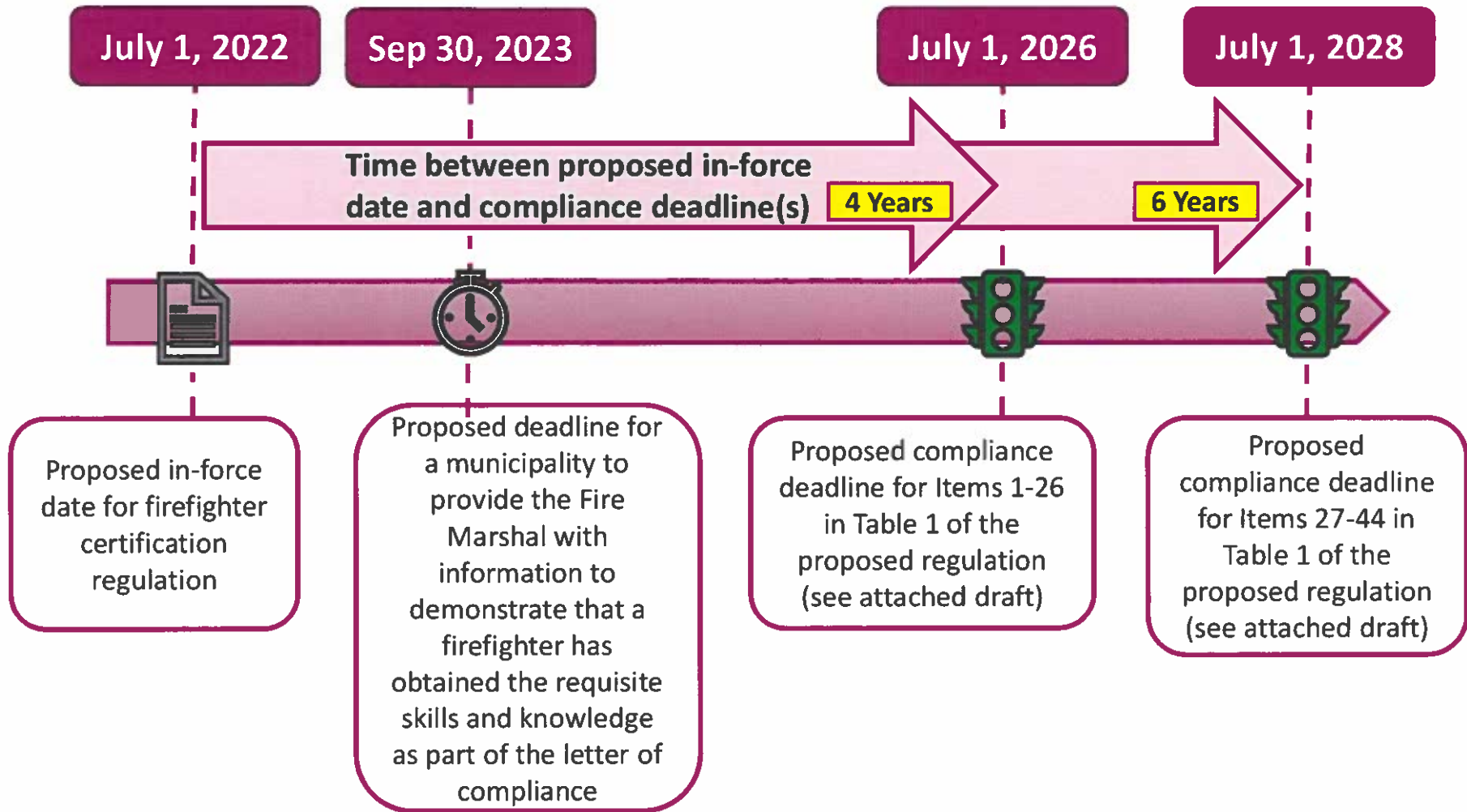

## Next Steps

- The Office of the Fire Marshal to review feedback received through multiple technical briefings (i.e., All Fire Chief Town Hall sessions) with municipal Fire Chiefs and continue to address any comments/questions received about the proposed regulation.
- Ministry to review and incorporate feedback on the proposed Firefighter Certification regulation received through the Ontario Regulatory Registry.

# Questions and Discussion

## JOINT BUILDING COMMITTEE

~~~

Representing: Burk's Falls, Ryerson, Joly, Machar,  
South River, Strong & Sundridge

PO Box 1120  
Sundridge, ON  
POA 1Z0  
(705)384-9444

February 24, 2022

Municipality of Magnetawan  
Attn: Kerstin Vroom, CAO Clerk  
PO Box 70  
Magnetawan, ON  
POA 1P0

### Re: Building Department Services

Dear Ms. Vroom:

The Joint Building Committee recently discussed options in dealing with coverage for the CBO and how that could be managed. The Committee directed me to reach out to your municipality to determine interest in sharing services for emergencies; such as unexpected illnesses and extended vacation leave.

If the Municipality of Magnetawan is interested in considering sharing these services, then an agreement could be drafted outlining specifics that is mutually agreed upon.

We look forward to your reply.

Sincerely,

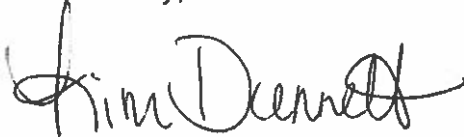

Kim Dunnett  
JBC Secretary  
(705)384-5819 Ext. 202



## REPORT TO COUNCIL

|                  |                             |
|------------------|-----------------------------|
| To:              | Mayor and Council           |
| From:            | Public Works Superintendent |
| Date of Meeting: | March 02, 2022              |
| Report Title:    | Truck #20 PWS Replacement   |

**Recommendation:** That Council receives and approves this report as presented and authorizes Staff to replace the Public Works Superintendent's Truck #21 with a 2021 1500 Classic St Quad Cab Truck in stock at MacLangs for \$47,724 (plus snow tires \$1,500) plus HST and to include this amount in the 2022 budget.

**Background:** This report is to update Council on the task to compare the cost and differences between a Quad Cab (formerly known as an extended cab which has 4 doors and less leg room than a Crew Cab) and Crew Cab (4 doors and the most leg room) Pickup Truck as directed by Council at the January 19<sup>th</sup>, 2022, Draft Budget Meeting.

The main purpose of the truck is for Road Patrol, Winter Maintenance Inspections, Public Works Emergencies, Project Inspections and Site Meetings with the Contractors and the general public. For the most part the truck has 1-2 occupants but on occasion depending on the project and/or emergency there could be between 3-4 occupants in the vehicle at one time which is the reasoning for the purchase of a Quad Cab Truck as it would be more convenient for space and transportation of equipment and will result in a higher resale value.

Staff reached out to the local Ford, Dodge, and Chevrolet Dealers. There is no longer a 2 door Extended Cab produced by the Big 3. The alternative would be to go with a Regular 2 Door sized Cab with an 8' Box and either a large toolbox and/or cap. Currently Pickup Truck # 21 only has a 6' box which is undersized for signposts and/or brush and debris that is regularly picked up.

**Evaluation:** At the time of this Report, Staff only had two dealerships respond: MacLangs (Dodge Dealership) and Bray Motors (Chevrolet) both in Sundridge

**MacLang Dodge:** Regarding the difference of the Extended cab to a Crew cab for the Dodge Ram 1500 series is somewhat minimal overall; however, the notable differences are that an Quad Cab offers a smaller seating area after of the front row seating whereas the Crew Cab offers more being an additional 9.6 "of rear seat legroom. For the Quad Cab the Headroom measures 39.2" with a Leg room of 35.6" in comparison to the Crew Cab which is a Headroom of 39.8" and a Legroom of 45.2" The additional space would be handy if mobilising a full Crew and gear to a jobsite. Regarding the length of the box this only comes in 6'4", for an 8' Box you need to step up to the 2500 series and above and or back to a Regular sized 2 Door Cab Pickup Truck.

**Brays Motors:** Regarding the difference of the Extended cab to a Crew cab for the Chevrolet of the Double Cab to a Crew Cab the rear Headroom measure 39.88" and the Legroom measuring 35.24". In comparison to the Crew Cab in which the Headroom measures 40.12" and the Legroom 43.40". As mentioned, the additional space would be handy if mobilising a full Crew and gear to a jobsite. Regarding the length of the box, they only come in 6'", for an 8' Box you need to go to a Regular sized 2 Door Cab.

**Financial Implications:** Are as follows:

|                                                                                                                                                              |          |
|--------------------------------------------------------------------------------------------------------------------------------------------------------------|----------|
| <b>2021 1500 Classic St Quad Cab</b> 4x4 with 6'4' Box (White), Back rack / Amber Light<br>In Stock at time of quote.<br>Quoted Estimate                     | \$47,724 |
| <b>2022 1500 Tradesman Crew Cab</b> 4x4 with 6'4" Box, Back rack/ Amber light<br>ETA approximately 12-17 weeks.<br>Quoted Estimate                           | \$55,854 |
| <b>2022 1500 Tradesman Regular Cab</b> 4x4 with 8' Box (White), Back rack/ Amber light<br>ETA of mid May 2022<br>Quoted Estimate                             | \$53,557 |
| <b>2022 Chevrolet Silverado Double Cab</b> 4x4 with 6'6" Box (White) , Back Rack / Amber Light<br>ETA approximately 6-8 weeks upon order.<br>Quoted Estimate | \$50,678 |
| <b>2022 Chevrolet Silverado Crew Cab</b> 4x4 with 6'6'Box, Back rack/ Amber light<br>ETA approximately 6-8 weeks upon order.<br>Quoted Estimate              | \$53,528 |

**Conclusion:** Taking into consideration the role of Truck #21 being the Public Works Superintendent Patrol Truck and on occasion being used for various operations by Staff when the need arises, the Public Works Superintendent recommends the 2021 1500 Classic Quad Cab based on price, availability, and the overall function of the vehicle. To note at the time of this Report there were three 2021 1500 Classic St Quad Cab Trucks available at MacLangs , that being said there could still be more available in Ontario as was our last purchase.

Respectfully Submitted,

*Scott Edwards*

Scott Edwards  
Public Works Superintendent

|                                                                                                                                                            |                                                                             |
|------------------------------------------------------------------------------------------------------------------------------------------------------------|-----------------------------------------------------------------------------|
|  <p data-bbox="235 325 503 411"><b>Municipality of<br/>Magnetawan</b></p> | <p data-bbox="779 241 1193 283"><b>REPORT TO COUNCIL</b></p>                |
| <p data-bbox="194 415 251 451">To:</p>                                                                                                                     | <p data-bbox="560 415 852 451">Mayor and Council</p>                        |
| <p data-bbox="194 462 284 493">From:</p>                                                                                                                   | <p data-bbox="560 462 1177 493">Linda Saunders, Treasurer/Tax Collector</p> |
| <p data-bbox="194 504 454 535">Date of Meeting:</p>                                                                                                        | <p data-bbox="560 504 787 535">March 2, 2022</p>                            |
| <p data-bbox="194 546 389 577">Report Title:</p>                                                                                                           | <p data-bbox="560 546 933 577">Schedule of Investments</p>                  |

**Recommendation:** THAT Council receives and approves this report as presented.

**Background:** As specified in the Municipality of Magnetawan’s Investment Policy, I have attached a list of the investments (GIC’s and bank accounts) that the Municipality of Magnetawan has on hand as of December 31, 2021.

Respectfully Submitted,



Linda Saunders  
Treasurer/Tax Collector

Municipality of Magnetawan  
List of Investments and Bank Balances as of December 31 2021

| Investment            | Amount         | Type            | Interest Rate | Maturity Date | Purpose                                    |
|-----------------------|----------------|-----------------|---------------|---------------|--------------------------------------------|
| Royal Bank            | \$6,295.50     | GIC             | 0.15%         | 05-Aug-22     | In Trust St Johns Dufferin Cemetery        |
| Royal Bank            | \$4,871.41     | GIC 0003        | 0.15%         | 15-Jul-22     | St Johns Dufferin Cemetery-savings account |
| Royal Bank            | \$235,039.20   | GIC 0005        | 0.30%         | 29-Nov-22     | Landfill Closure                           |
| Royal Bank            | \$12,784.40    | bank account    |               |               | Current account                            |
| Kawartha Credit Union | \$259,542.31   | RIC #4          | 0.80%         | 09-Nov-22     | Gas Tax                                    |
| Kawartha Credit Union | \$170,674.91   | RIC #420        | 0.30%         | 09-Nov-22     | Community Enhancement                      |
| Kawartha Credit Union | \$2,678,421.99 | RIC #418        | 1.50%         | 28-May-22     | Investments                                |
| Kawartha Credit Union | \$980,960.21   | bank account    | 1.75%         |               | current account                            |
| Kawartha Credit Union | \$77,935.72    | bank account    | 1.75%         |               | Parkland                                   |
| Kawartha Credit Union | \$25.00        | Share capital   |               |               |                                            |
| Kawartha Credit Union | \$16,899.00    | Affinity Shares |               |               |                                            |



Moved by: \_\_\_\_\_

Seconded by: \_\_\_\_\_

**WHEREAS;** Council has received correspondence and required fees from Collin James requesting the deeming together of PT LOT 11 W/S N and PT LOTS 11 & 12 in PLAN 319;

**NOW THEREFORE BE IT RESOLVED THAT** the Council of the Municipality of Magnetawan supports in principle the deeming together of PT LOT 11 W/S N and PT LOTS 11 & 12 in PLAN 319 in the Village of Magnetawan and directs staff to bring back the by-law for passing to a future Council meeting.

Carried \_\_\_\_\_ Defeated \_\_\_\_\_ Deferred \_\_\_\_\_

\_\_\_\_\_  
Sam Dunnett, Mayor

Recorded Vote Called by: \_\_\_\_\_

Recorded Vote

| Member of Council   | Yea | Nay | Absent |
|---------------------|-----|-----|--------|
| Brunton, Tim        |     |     |        |
| Hetherington, John  |     |     |        |
| Kneller, Brad       |     |     |        |
| Smith, Wayne        |     |     |        |
| Mayor: Dunnett, Sam |     |     |        |

MUNICIPALITY OF  
MAGNETAWAN

FEB 08 2022

RECEIVED

Collin James  
PO Box 313  
Magnetawan, ON POA 1P0  
705-387-1800

February 1, 2022

Municipality of Magnetawan  
PO Box 70  
Magnetawan, ON POA 1P0

**RE: Deeming By-law**

To Municipal Council,

I am writing this letter to request that you pass a deeming bylaw to deem the following parcels together:

PLAN 319 PT LOT 11 W/S N – 4944 020 00106300.0000

PLAN 319 PT LOTS 11 & 12 – 4944 020 00106400.0000

Thank you for your consideration.

Kind regards,

A handwritten signature in black ink, appearing to be 'Collin James', written in a cursive style.

Collin James







Municipality of  
Magnetawan

# Municipality of Magnetawan

**Background Report:**

## **Official Plan and Zoning By-law Review and Update**

February 23, 2022





## Table of Contents

|       |                                                                |    |
|-------|----------------------------------------------------------------|----|
| 1.0   | Introduction.....                                              | 3  |
| 1.1   | Official Plan Update.....                                      | 3  |
| 1.2   | Zoning By-law Update.....                                      | 4  |
| 2.0   | Municipality of Magnetawan - Regional Context.....             | 5  |
| 3.0   | Official Plan for the Municipality of Magnetawan, 2012 .....   | 6  |
| 4.0   | Municipality of Magnetawan Zoning By-law No. 2001-26.....      | 8  |
| 5.0   | Provincial and Other Local Documents .....                     | 9  |
| 5.1   | One Window Planning Service .....                              | 9  |
| 5.2   | Planning Act, R.S.O. 1990.....                                 | 9  |
| 5.2.1 | Section 16(3) - Additional Residential Units .....             | 9  |
| 5.2.2 | Section 28 - Community Improvement Plans.....                  | 9  |
| 5.3   | Provincial Policy Statement (2020).....                        | 10 |
| 5.4   | A Place to Grow: Growth Plan for Northern Ontario (2011) ..... | 10 |
| 5.5   | Regional Economic Development Strategic Plan (RED Plan) .....  | 11 |
| 6.0   | Stakeholder Engagement and Community Consultation .....        | 12 |
| 6.1   | Public Issues Identification .....                             | 13 |
| 7.0   | Mapping Updates .....                                          | 16 |
| 8.0   | Conclusions .....                                              | 17 |



## 1.0 Introduction

---

In mid-2021, the Municipality of Magnetawan initiated the process to update the Municipality of Magnetawan Official Plan (MMOP) and Zoning By-law. As part of that process, EcoVue Consulting Services Inc. (EcoVue), in tandem with Municipality's OP Update Steering Committee, have been collecting background information that will inform the changes to be made to the MMOP. This report will provide a summary of information that has been reviewed and discuss the direction for the new Official Plan and Zoning By-law.

### 1.1 Official Plan Update

An Official Plan is the primary tool for guiding land use planning within a municipality. A municipal Official Plan sets out policies regarding how land in a community will be used and establishes a framework of goals and objectives that direct growth within a 20-year horizon. Although it is focused primarily on land use, the Official Plan must be all-inclusive in its direction by including economic, environmental, and cultural themes within the goals and objectives. These goals and objectives provide direction to municipal staff and Council, landowners, developers and the community at large.

The proposed update to the Municipality of Magnetawan Official Plan (MMOP) will be based on an outlook to 2042, and provide an update to the current Official Plan that was adopted by Council and approved by the Ministry of Municipal Affairs and Housing (MMAH) in 2012. A number of changes to Provincial policies have occurred since the current OP was adopted in 2010 – most notably, updates to the *Planning Act*, the 2020 Provincial Policy Statement, and the A Place to Grow: Growth Plan for Northern Ontario (2011). Modifications to the MMOP will be made to bring the Plan into conformity with these documents, where necessary.

As required under Section 26 of the *Planning Act*, the Official Plan Update project was introduced to Council on July 21, 2021. A Stakeholder Open House was held on October 20, 2021, where the project was introduced to important community groups and initial comments, concerns, and priorities for the OP/ZBL update were gathered. A Public Open House was held on November 18, 2021, to obtain preliminary input from residents.

This Background Report provides a summary of comments received during the initial public consultation.

The information provided in this report should not be considered exhaustive. It is our intention to continue to gather information throughout the Official Plan Update in order to ensure that the final document encapsulates all policies and regulations, including those that may be implemented during the update process.

Further public and community stakeholder sessions will be held in the coming months to solicit comments and questions from residents and stakeholders. Comments and suggestions from residents and community stakeholders will influence the introduction of new policies and updates to existing polices. Once the Official Plan final draft is created, a Statutory Public Meeting will take place for the Plan to be presented to the public and to allow for a review of the document.



## 1.2 Zoning By-law Update

In addition to the update of the Magnetawan Official Plan, EcoVue and municipal staff will be working together to update the Municipality's Zoning By-law. A Zoning By-law implements the Official Plan policies, goals and objectives by regulating the use of land within a community.

The Zoning By-law regulates how land may be used, where buildings and structures can be located, lot sizes, setback requirements, building heights and parking requirements. In addition to a new text document, the update will also include the introduction of Zoning Schedules (maps) that identify zones across the Municipality. The zones on the schedule will correspond with a set of regulations outlined in the By-law.







## 2.0 Municipality of Magnetawan - Regional Context

---

The Municipality of Magnetawan covers an area of approximately 532 km<sup>2</sup> located along the shores of the Magnetawan River in the Almaguin Highlands region of the Parry Sound District. The Municipality is a single-tier municipality situated along Highway 520, approximately 45 minutes north-west of Huntsville, and 1 hour south of North Bay.

The main Village of Magnetawan features a traditional downtown core surrounded by low-density residential development, mostly in the form of single detached dwellings. There are a variety of other uses located within the Village, such as commercial (e.g. Algonquin Fine Foods), institutional (e.g. the Magnetawan Historical Museum), and industrial uses. The other rural settlement area within the Municipality of Magnetawan is the Hamlet of Ahmic Harbour, which hosts a variety of commercial/tourist, residential, and industrial uses.

According to the 2021 Census, the population of Magnetawan is 1,753. This represents a 20.7% increase from the 2016 census. According to the 2016 Census, the median age of residents within the Municipality is 57.4 years old, 17 years older than the Provincial average.





### 3.0 Official Plan for the Municipality of Magnetawan, 2012

Section 26.1 of the *Planning Act* that requires the municipality to revise its Official Plan no less frequently than 10 years after it comes into effect as a new official plan, and every five years thereafter, unless the plan has been replaced by another new official plan. This policy is in place to ensure that the Official Plan:

- a) conforms with provincial plans, including the Provincial Policy Statement 2020 (PPS) and the Growth Plan for Northern Ontario, 2011 (Growth Plan), or does not conflict with them, as the case may be;
- b) has regard to matters of provincial interests; and
- c) that it conforms to other provincial policy documents issued under the *Planning Act*.

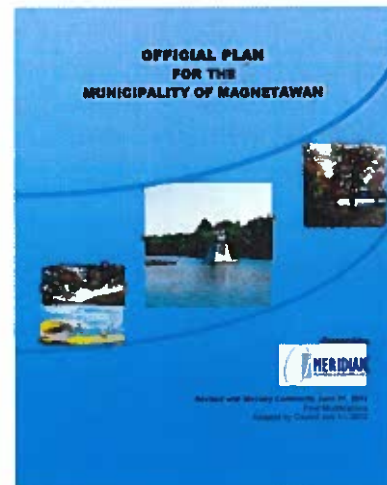

The Municipality of Magnetawan Official Plan has not been updated since it was adopted and granted final approval in 2012.

There have been a number of changes to Provincial plans and policy documents since the approval of the plan 10 years ago.

To ensure conformity with the PPS, policies to be addressed in the revised Official Plan include, but are not limited to:

- Policies to ensure the adequate provision of employment opportunities and the adequate provision of a full range of housing, including affordable housing;
- Policies to establish minimum targets for affordable housing;
- Policies to support the conservation of features of significant architectural, cultural, historical, archaeological or scientific interest;
- Policies to encourage public service facilities to be co-located in community hubs; and
- Policies that identify goals, objectives and actions to mitigate greenhouse gas emissions and to provide for adaptation to a changing climate, including through increasing resiliency.

EcoVue has reviewed the current Official Plan to determine areas that can be improved through the update process, including (but not limited to):

1. Determining the feasibility of policies for diversified housing options within the Municipality, including (but not limited to) tiny homes, row housing, etc.;
2. Identifying and promoting employment land districts (see the Provincial Policy Statement section below) in order to provide an adequate land inventory for possible future employment uses (e.g. manufacturing, prestige industrial, etc.);
3. Providing the greatest possible flexibility for redevelopment within the floodplains of hydrologic features within the Municipality, including the Magnetawan River floodplain;
4. Providing clarity relating to Short Term Accommodations, and provide the Municipality with the authority to require a license to operate short term rentals such as "Airbnbs";



5. Incorporating policies within the Official Plan which provide Council the flexibility to create and implement a Community Improvement Plan (CIP) within Magnetawan;
6. Clarifying policies related to Natural Heritage and Natural Hydrologic Features, including updating technical requirements when proposing new land uses or buildings/structures; and
7. Mapping - improving on the existing Official Plan schedule by incorporating more detailed mapping schedules for greater clarity regarding general development policies.

From an amendment perspective, the Municipality has not amended the MMOP since adoption in 2012.



- Additional Residential Dwellings

- Public seems to generally support the creation of Additional Residential Dwellings (commonly referred to as Secondary Dwellings) on residential properties; however, with requests for specific provisions (some of which are conflicting):

*"I think that second dwellings are a good idea on the main street. For example, I think that apartments should be allowed to be built in the hotel space above the Grill & Grocery. This would help allow the business to succeed in the off season. As well on some of the lots that are at 1/2 an acre the municipality could allow the lot to be subdivided for a second dwelling. This may help ensure the families inhabit the village, keeping our school and businesses functioning. In former years, families used to be much bigger. Families often have only 1 or 2 children. So it makes sense to allow properties that are 1/2 an acre to be subdivided so that two home could be built on them";*

*"My Ahmic cottage owners have had rooms above boathouses. I'm in favour of this provided the boathouse room has a compostable toilet (or some other green solution). I am not in favour of a second house or trailer on a 1 acre lot, eg 10 George Street, Magnetawan. If the property is 2 acres or larger, I have less concern. Septic tanks and beds need room to function properly. No townhouses or semi-detached! I moved here to get away from that and have some privacy".*

- Therefore, clarification on lot requirements will be required if Additional Residential Dwellings are to be supported in the OP/ZBL Update.

- Tiny Homes

- Similar to Additional Residential Dwellings, residents seem to be supportive, but with specific provisions:

*"There shouldn't be restrictions on how small you can build but definitely on the number of dwelling units per lot (or lot size for larger lots). I wouldn't want to see essentially 'subdivisions' pop up where at one time only one more typically sized building would be allowed. There should be reasonable limits on the number of dwellings allowed on a lot based on the size of the lot".*

- Residents have also expressed concern with regulating Tiny Homes:

*"I don't think it makes sense to have different regulations for different types of dwellings. Look at trailers are dwelling units but are not assessed as such for property tax purposes. Different regulations for different size dwellings opens the door for litigation, community friction, enforcement issues."*

- Environmental stewardship

- Residents expressed concern with development adjacent to natural features such as wetlands and lakes. In particular, residents on the major lakes in the Municipality (Ahmic, Cecebe, and Horn) are concerned with lake water quality and over-development of the shoreline.



- There is also concern with tree cutting, and the potential impacts of uncontrolled tree clearing on private land
- **Support for local businesses**
  - Residents want more services (health, social, financial, etc.) within the Municipality in order to attract new residents, which will, in turn, bolster the local business community.
  - There is support for a municipal grant or incentivization system in order to attract more business to the Village.

We will continue to expand this list through public consultation throughout the review and update process.





## 7.0 Mapping Updates

---

As a part of the Official Plan and Zoning By-law update, revisions will be made to the Land Use maps (schedules) of the Municipality of Magnetawan Official Plan and Zoning By-law.

The revised land use Schedule for the MMOP is based on Schedule A to the current Official Plan, and provides some additional designations. Proposed designations identified on Schedule "A" to the Official Plan include the Core Area (Downtown), Employment Areas, Future Development, and Environmental Protection.

The revised Zoning By-law schedules, using the current Zoning Schedules, will identify and assign additional zones, where necessary, to all properties within the Municipality based on existing uses and the overarching land use designation in the MMOP.

Both the revised Official Plan schedules and Zoning By-law schedules will be made available when the draft documents are circulated for review.



## 8.0 Conclusions

---

Official Plans are the primary guiding land use planning tool in a municipality. The Official Plan provides a framework of goals and objectives to direct growth. It is important to update them to reflect the most current goals and visions of the Village as well as the current provincial plans.

There are many policies and regulations within provincial, municipal or agency documents and guidelines that the municipality must address as part of the Official Plan and Zoning By-law update. The information provided in this report is not exhaustive. It is our intention to continue to gather information throughout the Official Plan and Zoning By-law update process to ensure the Official Plan and Zoning By-law encapsulate all polices and regulations, as well as the general goals and objectives of the residents and stakeholders. At this point, the information obtained in our initial meeting has provided us with a strong basis for conducting future stakeholder and roundtable sessions.

We look forward to gathering further information and integrating new ideas into draft policies as the Official Plan and Zoning By-law update process continues.

Respectfully submitted,

**ECOVUE CONSULTING SERVICES INC.**

  
\_\_\_\_\_  
**J. Kent Randall B.E.S. MCIP RPP**  
**Principal Planner**







**THE CORPORATION OF THE MUNICIPALITY OF MAGNETAWAN**

**BY-LAW NO. 2022 -**

**Being a By-law to establish a Committee of Adjustment for the Municipality of Magnetawan for 2022**

---

**WHEREAS** Section 44(1) of the Planning Act, R.S.O. 1990, Chapter P.13, authorizes a municipality to constitute and appoint a Committee of Adjustment;

**AND WHEREAS** Section 44(3) of the Planning Act, R.S.O. 1990, Chapter P.13, the members of the committee who are members of a municipal council shall be appointed annually;

**AND WHEREAS** Section 45 (1) The committee of adjustment, upon the application of the owner of any land, building or structure affected by any by-law that is passed under section 34 or 38, or a predecessor of such sections, or any person authorized in writing by the owner, may, despite any other Act, authorize such minor variance from the provisions of the by-law, in respect of the land, building or structure or the use thereof, as in its opinion is desirable for the appropriate development or use of the land, building or structure, if in the opinion of the committee the general intent and purpose of the by-law and of the official plan, if any, are maintained;

**AND WHEREAS** Section 45 (3) A council that has constituted a committee of adjustment may by by-law empower the committee of adjustment to grant minor variances from the provisions of any by-law of the municipality that implements an official plan, or from such by-laws of the municipality as are specified and that implement an official plan, and when a committee of adjustment is so empowered subsection (1) applies with necessary modifications. R.S.O. 1990, c. P.13, s. 45 (3);

**NOW THEREFORE** the Council of the Corporation of the Municipality of Magnetawan hereby enacts as follows:

1. **THAT** the following persons, all of whom are members of Council, are hereby appointed as its members for the 2022 calendar year until the inauguration of the newly elected Council:
  - Sam Dunnett
  - Tim Brunton
  - John Hetherington
  - Brad Kneller
  - Wayne Smith
2. **THAT** the Committee of Adjustment shall be hereby empowered with the authority to grant minor variances from the provisions of any by-law of the municipality that implements an Official Plan.
3. That the Clerk of the Municipality of Magnetawan is hereby appointed as the Secretary-Treasurer of the Committee of Adjustment. The Clerk may delegate to any employee of the Municipality of Magnetawan all, or a portion of, the duties of Secretary-Treasurer of the Committee of Adjustment.
4. **THAT** this By-law shall come into force and effect on January 01, 2022.

## Kerstin Vroom

---

**From:** Tammy Wylie <treasurer@burksfalls.ca>  
**Sent:** February 11, 2022 3:18 PM  
**To:** Kerstin Vroom; Admin Assistant  
**Subject:** RE: Letter re: AHHC contribution and invoices

Good Afternoon Kirsten,

1. The request for financial support in the amount of \$3,300 is to help offset the 2020 deficit. The budgetary control that you received is for the year 2020 and clearly shows a deficit of \$36,266.
2. The budgetary control "Current" column represents any adjustments that were done in 2021 that to 2020 not 2021 actuals.
3. The payment of \$4,545 was used to offset the 2019 deficit, even though Magnetawan did not pay it until 2021. Mayor Cathy Still and Councillor Rod Ward attended a Magnetawan council meeting in 2021 to answer questions and provide evidence with respect to the 2019 deficit.
4. As for the 2020 municipal contributions being budgeted at \$13,635, I am assuming, because I was not hear at the time, that at the time the 2020 budget was prepared Burk's Falls did not really know how many municipalities were actually going to contribute financially.

I hope this helps to clarify.



**Tammy Wylie**  
Treasurer  
Telephone 705-382-3138  
Web [www.burksfalls.net](http://www.burksfalls.net)  
172 Ontario Street; Box 160  
Burk's Falls ON P0A 1C0

---

**From:** Kerstin Vroom <Clerk@magnetawan.com>  
**Sent:** February 11, 2022 1:52 PM  
**To:** Admin Assistant <AHHC@burksfalls.ca>  
**Cc:** Tammy Wylie <treasurer@burksfalls.ca>  
**Subject:** RE: Letter re: AHHC contribution and invoices

Hi Camille!  
Thanks for your help.

Just want to confirm that Budgeted for Municipal Contributions was \$13,635.00 and year to date actuals for Municipal Contributions was \$30,392.87. Were all of these contributions allocated for the 2019 deficit?

Also, the \$4,545 that shows as a contribution under Current – I am assuming that it 2021? And that is the funds we sent in May?

Appreciate your clarification.

Thanks!  
*Kerstin*

---

**From:** Admin Assistant <[AHHC@burksfalls.ca](mailto:AHHC@burksfalls.ca)>  
**Sent:** February 11, 2022 9:24 AM  
**To:** Kerstin Vroom <[Clerk@magnetawan.com](mailto:Clerk@magnetawan.com)>  
**Cc:** Tammy Wylie <[treasurer@burksfalls.ca](mailto:treasurer@burksfalls.ca)>  
**Subject:** RE: Letter re: AHHC contribution and invoices

Good morning Kerstin,  
Our financial statements are on our website for you to view. I have attached the budget actuals for 2020.  
Hope this information is helpful and have a great day.  
Camille Barr

---

**From:** Kerstin Vroom <[Clerk@magnetawan.com](mailto:Clerk@magnetawan.com)>  
**Sent:** February 10, 2022 4:38 PM  
**To:** Admin Assistant <[AHHC@burksfalls.ca](mailto:AHHC@burksfalls.ca)>  
**Cc:** Tammy Wylie <[treasurer@burksfalls.ca](mailto:treasurer@burksfalls.ca)>  
**Subject:** RE: Letter re: AHHC contribution and invoices

Hi Camille  
Thank you for the clarification.  
I understand now that every year Burk's Falls will just be sending out an invoice for the deficit.  
Is it possible to get a copy of the financials for the Health Care Centre showing the deficit? And perhaps a budget to actual for 2020?

Thanks!  
*Kerstin*

---

**From:** Admin Assistant <[AHHC@burksfalls.ca](mailto:AHHC@burksfalls.ca)>  
**Sent:** February 10, 2022 3:37 PM  
**To:** Kerstin Vroom <[Clerk@magnetawan.com](mailto:Clerk@magnetawan.com)>  
**Cc:** Tammy Wylie <[treasurer@burksfalls.ca](mailto:treasurer@burksfalls.ca)>  
**Subject:** RE: Letter re: AHHC contribution and invoices

Good afternoon Kerstin,  
Attached is the report that was sent out requesting the annual support from the 11 municipalities in the amount of \$4545.00. This amount represented the 2019 deficit. The \$3300.00 is the actual portion of the 2020 deficit being requested of the municipalities.

---

**From:** Kerstin Vroom <[Clerk@magnetawan.com](mailto:Clerk@magnetawan.com)>  
**Sent:** February 10, 2022 2:18 PM  
**To:** Admin Assistant <[AHHC@burksfalls.ca](mailto:AHHC@burksfalls.ca)>

**Cc:** Tammy Wylie <[treasurer@burksfalls.ca](mailto:treasurer@burksfalls.ca)>  
**Subject:** RE: Letter re: AHHC contribution and invoices

Thanks Camille!

Could you kindly provide some background to the request for new ask of \$3,300. Council would usually get a letter or report, with budgets and/or past financials from the Board or the Municipality.  
Also, Council will probably also want some idea of where the \$4,545 was used for.

I can put this on the next agenda for consideration.

Much appreciated!

Thanks!  
*Kerstin*

---

**From:** Admin Assistant <[AHHC@burksfalls.ca](mailto:AHHC@burksfalls.ca)>  
**Sent:** February 10, 2022 2:03 PM  
**To:** Kerstin Vroom <[Clerk@magnetawan.com](mailto:Clerk@magnetawan.com)>  
**Cc:** Tammy Wylie <[treasurer@burksfalls.ca](mailto:treasurer@burksfalls.ca)>  
**Subject:** RE: Letter re: AHHC contribution and invoices

Good afternoon Kerstin,  
We did receive your payment for the physiotherapist rent. Thank you for reaching back out to us on that.  
In regards to the \$3300.00, yes, this is a new request for the 2020 deficit the building incurs.  
Thank you again.

---

**From:** Kerstin Vroom <[Clerk@magnetawan.com](mailto:Clerk@magnetawan.com)>  
**Sent:** February 10, 2022 1:52 PM  
**To:** Admin Assistant <[AHHC@burksfalls.ca](mailto:AHHC@burksfalls.ca)>  
**Cc:** Tammy Wylie <[treasurer@burksfalls.ca](mailto:treasurer@burksfalls.ca)>  
**Subject:** RE: Letter re: AHHC contribution and invoices

Hello Camille,

Thank you for forwarding this information.

Could you kindly confirm that you have received our cheque in November 2021 for the physiotherapist 'one month rent' request.

Also, we did send a payment in the amount of \$6,145, in May last year as requested through a deputation from Rod and Cathy for the following:

\$1,600 (one-time) to assist with physician recruitment incentives and \$4,545 (one-time) to assist with building costs. Council, at this time, did not approve the \$500 annual share for OTN.

The invoice you have sent for \$3,300 for: *2022 contribution towards the 2020 AHHC deficit*, is this a new 'ask' or are the above mentioned funds being used?

Appreciate the clarification,  
*Kerstin*

Kerstin Vroom, CMO, Dipl. M.A, CMM I | CAO/Clerk

Municipality of Magnetawan | PO Box 70 | 4304 Highway 520 | Magnetawan, ON POA 1P0  
Phone 705-387-3947 ext. 1001 | Fax 705-387-4875 | [clerk@magnetawan.com](mailto:clerk@magnetawan.com)



*This message (including attachments, if any) is intended to be confidential and solely for the addressee. If you received this e-mail in error, please delete it and advise me immediately. E-mail transmission cannot be guaranteed to be secure or error-free and the sender does not accept liability for errors or omissions.*

---

**From:** Admin Assistant <[AHHC@burksfalls.ca](mailto:AHHC@burksfalls.ca)>  
**Sent:** February 9, 2022 12:10 PM  
**To:** Kerstin Vroom <[Clerk@magnetawan.com](mailto:Clerk@magnetawan.com)>  
**Cc:** Tammy Wylie <[treasurer@burksfalls.ca](mailto:treasurer@burksfalls.ca)>  
**Subject:** Letter re: AHHC contribution and invoices

Good morning Kerstin,  
Please find attached a letter regarding the AHHC contribution and corresponding invoice. Additionally I have attached the physiotherapist start up invoice.  
Regards,



**Camille Barr**

Administrative Assistant



705-382-3138 Ex. 224



[www.burksfalls.net](http://www.burksfalls.net)



[thevillageofburksfalls](https://www.instagram.com/thevillageofburksfalls)



[The Village of Burk's Falls](https://www.facebook.com/TheVillageofBurksFalls)

Report Date  
2021-04-26 3:06 PM

Village of Burk's Falls  
Budgetary Control  
For the Period 2020-01-01 - 2020-12-31

| Account # / Description                           | Committed | <sup>2021</sup><br>Current | <sup>2020</sup><br>Year to Date | <sup>2020</sup><br>Budget | Variance         | %           |
|---------------------------------------------------|-----------|----------------------------|---------------------------------|---------------------------|------------------|-------------|
| 15-540 - Health Centre Rental Revenue             |           | 9,095.52                   | 149,171.62                      | 143,003.00                | 6,168.62         | 4.3         |
| 15-543 - Health Centre - Donation revenue         |           | 685.85                     | 1,145.85                        | 500.00                    | 645.85           | 129.2       |
| 15-544 - Health Centre-Other Revenues             |           | 376.11                     | 4,513.32                        | 4,513.00                  | 0.32             |             |
| 15-545 - AHHC-Municipal Contributions             |           | (4,545.00)                 | 30,392.87 ①                     | 13,635.00                 | 16,757.87        | 122.9       |
| <b>Revenue Totals:</b>                            |           | <b>5,612.48</b>            | <b>185,223.66</b>               | <b>161,651.00</b>         | <b>23,572.66</b> | <b>14.6</b> |
| 16-5401 - AHHC-Wages & Benefits                   |           | (12,463.75)                | 27,075.62                       | 33,933.00                 | 6,857.38         | 20.2        |
| 16-5402 - AHHC-Hydro                              |           | 10,644.40                  | 37,780.80                       | 42,266.00                 | 4,485.20         | 10.6        |
| 16-5403 - AHHC-Natural Gas                        |           | 821.80                     | 5,048.32                        | 5,000.00                  | (48.32)          | 1.0-        |
| 16-5404 - AHHC-Fuel Oil                           |           |                            | 2,017.24                        | 4,000.00                  | 1,982.76         | 49.6        |
| 16-5406 - AHHC-Cleaning materials                 |           | 1,066.53                   | 5,621.64                        | 5,000.00                  | (621.64)         | 12.4-       |
| 16-5406-1 - AHHC-Janitorial Contract              |           | 3,500.00                   | 21,153.65                       | 21,440.00                 | 286.35           | 1.3         |
| 16-5407 - AHHC-Pest Control                       |           | 65.00                      | 843.60                          | 780.00                    | (63.60)          | 8.2-        |
| 16-5408 - AHHC-Water & Sewer                      |           | 753.88                     | 2,317.40                        | 3,000.00                  | 682.60           | 22.8        |
| 16-5409 - AHHC-Insurance                          |           |                            | 7,363.64                        | 7,364.00                  | 0.36             |             |
| 16-541 - Health Centre capital expenditures       |           | 1,144.63                   | 9,239.80                        | 20,000.00                 | 10,760.20        | 53.8        |
| 16-5410 - AHHC-Snow Removal                       |           | 9,141.18                   | 15,221.18                       | 10,500.00                 | (4,721.18)       | 45.0-       |
| 16-5411 - AHHC-Elevator Repairs & Maintenance     |           |                            | 2,957.38                        | 4,000.00                  | 1,042.62         | 26.1        |
| 16-5413 - AHHC-Building Maintenance               |           | 4,142.81                   | 12,437.15                       | 17,700.00                 | 5,262.85         | 29.7        |
| 16-5415 - AHHC-Property taxes                     |           |                            | 7,344.29                        | 7,402.00                  | 57.71            | 0.8         |
| 16-5416 - AHHC-Miscellaneous                      |           | 277.12                     | 2,392.12                        | 1,000.00                  | (1,392.12)       | 139.2-      |
| 16-5418 - AHHC-Telephones                         |           | 242.48                     | 2,906.15                        | 2,874.00                  | (32.15)          | 1.1-        |
| 16-542 - Health Centre loan interest repayments   |           | 152.46                     | 2,018.97                        | 2,005.00                  | (13.97)          | 0.7-        |
| 80-110 - To be Recovered (I/S) Health Centre loan |           | 2,292.37                   | 27,357.43                       | 27,371.00                 | 13.57            | 0.1         |
| <b>Expense Totals:</b>                            |           | <b>21,780.91</b>           | <b>191,096.38</b>               | <b>215,635.00</b>         | <b>24,538.62</b> | <b>11.4</b> |
| <b>Net Surplus (Deficit):</b>                     |           | <b>(16,168.43)</b>         | <b>(5,872.72)</b>               | <b>(53,984.00)</b>        | <b>48,111.28</b> | <b>89.1</b> |

Less: 2020 municipal contributions  
to cover deficit

2020 deficit with no municipal  
contributions = estimated 2021  
deficit with no municipal contributions  
÷ 11 municipalities

① (30,392.87)

(36,266 -)

÷ 11

~  
3,300- per municipality

Accounts Printed: 22

**Village of Burk's Falls**

172 Ontario Street  
PO Box 160  
Burk's Falls ON P0A 1C0



Phone: 705-382-3138  
Fax: 705-382-2273  
E-mail: [treasurer@burksfalls.ca](mailto:treasurer@burksfalls.ca)

Invoice to:  
Municipality of Magnetawan  
4304 Hwy 520, P.O. Box 70  
Magnetawan, ON  
P0A 1P0

Date: February 4, 2022  
Invoice # 2022-018

| QTY | DESCRIPTION                                     | UNIT PRICE  | LINE TOTAL  |
|-----|-------------------------------------------------|-------------|-------------|
| 1   | 2022 contribution towards the 2020 AHHC deficit | \$ 3,300.00 | \$ 3,300.00 |

This invoice is payable upon receipt to:  
The Village of Burk's Falls  
PO Box 160  
Burk's Falls, ON P0A 1C0

Total \$ 3,300.00

FEB 22 2022

RECEIVED

324 Chapman Dr. E.,  
R.R. 3, Burk's Falls ON  
P0A 1C0

22 February 2022

Magnetawan Municipal Council

Dear Members of Council,

I write out of concern for the condition of the road allowance that connects eastern and western parts of the current Chapman Drive like the hypotenuse of a triangle. This road allowance was the originally named Chapman Drive, and is still so named on Registered Plan M-503 (1981).<sup>1</sup> At one point a dump was created in the road allowance, about mid-way, on both the north and south sides of the original roadway. To this day the rubbish remaining—largely rusting metal and broken glass—is an eyesore for those who walk the trail on the former roadway. Moreover, the dump may constitute an environmental and health hazard.

The dumping ground is not only an ugly blot on the wooded area that bounds the trail, but also exists contrary to the By-laws of the Municipality. The rusting metal and glass meet the definition of “rubbish” in the By-laws, and the continuing existence of this rubbish contravenes section 3.1.1 of the By-laws.

The rusting “heavy metal”—tin, iron and steel—likely constitutes a polluting factor for the Magnetawan waterways. Reading a recent article, “Heavy metal pollution in the environment and their toxicological effects on humans,” has raised my concern about this likelihood.<sup>2</sup> While it would not be industrial-level contamination, rain and snowmelt must be carrying elements of the rusting metals into the water table and ultimately to the creek that empties into L. Cecebe near the junction of Highway 520 and Chapman Dr. West. This cannot be something for which the Municipality would want to carry continuing responsibility.

I am requesting that Council take action to bring about the clean-up of this dump. I believe that many of us who walk the trail would be willing to assist in aspects of such a project. In this time of global ecological crisis, what we can do locally to prevent the degradation of nature is more important than ever.

Faithfully,



(The Rev. Dr.) Peter Wyatt

---

<sup>1</sup> On Plan M-503, present-day Chapman Drive is named as “Lakeshore Drive,” with “Leader Lane” connecting it to then Chapman Dr.

<sup>2</sup> <https://doi.org/10.1016/j.heliyon.2020.e04691>.



Moved by: \_\_\_\_\_

Seconded by: \_\_\_\_\_

**WHEREAS** the Council of the Municipality of Magnetawan is always looking to improve and extend the useful life of social and recreational facilities while maintaining excellent service to our residents;

**AND WHEREAS**, the Municipality has submitted an application to request funding from the Northern Ontario Heritage Fund Corporation (NOHFC) towards the Outdoor Rink and Community Centre Improvement Project to repair Magnetawan Community Centre Roof and to repair the Pavilion Outdoor Rink in the estimated amount of \$320,000;

**AND WHEREAS**, if the Municipality is successful in obtaining a grant in the amount of \$200,000, the Municipality is committed to cover our contribution towards the project in the amount of \$55,000 along with any project cost overruns for this much needed project;

**NOW THEREFORE BE IT RESOLVED**, that the Council of the Municipality of Magnetawan deems it in the best interest of the Municipality to authorize the payment of any project cost overruns over and above the awarded grant funding.

Carried \_\_\_\_\_ Defeated \_\_\_\_\_ Deferred \_\_\_\_\_

\_\_\_\_\_  
Sam Dunnett, Mayor

Recorded Vote Called by: \_\_\_\_\_

Recorded Vote

| Member of Council   | Yea | Nay | Absent |
|---------------------|-----|-----|--------|
| Brunton, Tim        |     |     |        |
| Hetherington, John  |     |     |        |
| Kneller, Brad       |     |     |        |
| Smith, Wayne        |     |     |        |
| Mayor: Dunnett, Sam |     |     |        |

Moved by: \_\_\_\_\_

Seconded by: \_\_\_\_\_

**WHEREAS** the Council of the Municipality receives the correspondence from Matt Foulk, Ghost Gravel Cycling Event revising the route for the 2022 Ghost Gravel Cycling Event approved by motion 2022-31;

**NOW THEREFORE BE IT RESOLVED** that the Council of the Municipality of Magnetawan supports the Cycling event to be hosted on Saturday August 20, 2022 at no charge with the following conditions;

- No roads will be blocked and cyclists will not impede the flow of traffic
- Insurance indemnifying the Municipality in the amount of \$5,000,000 is submitted to the Clerk prior to the event
- The advertisements reflect that the rest stop is in Magnetawan, ON
- All applicable COVID-19 guidelines must be followed

**AND FURTHER THAT** motions 2021-364 and 2022-33 are rescinded.

Carried \_\_\_\_\_ Defeated \_\_\_\_\_ Deferred \_\_\_\_\_

\_\_\_\_\_  
Sam Dunnett, Mayor

Recorded Vote Called by: \_\_\_\_\_

Recorded Vote

| Member of Council   | Yea | Nay | Absent |
|---------------------|-----|-----|--------|
| Brunton, Tim        |     |     |        |
| Hetherington, John  |     |     |        |
| Kneller, Brad       |     |     |        |
| Smith, Wayne        |     |     |        |
| Mayor: Dunnett, Sam |     |     |        |

## Laura Brandt

---

**Subject:** FW: Ghost Gravel August 2022

**From:** Matt Foulk <matt@jollygood.ca>  
**Sent:** February 10, 2022 11:23 AM  
**To:** Laura Brandt <lbrandt@magnetawan.com>  
**Subject:** Re: Ghost Gravel August 2022

No problem at all Laura! Please see below and edit as you see fit. Any questions let me know!

### Route

While subject to change over the coming months based on recon trips, the high-level route will be counter-clockwise from South River heading NW along Jerusalem and down the Old Nipissing Road to Magnetawan. Back to South River NE via Eagle Lake. Thereafter an optional clockwise loop eastward. Over 80% of the route will be on backroads and gravel away from main roads as much as possible.

### Ride not race

Ghost Gravel is designed to be a ride not a race, in that we want riders to fully take in their surroundings, as opposed to being 'head down' and against the clock. Therefore the event will not be timed. While perceptions are changing, cyclists generally tend to associate OCA sanctioning with racing.

**RESOLUTION NO. 2022 - 31** **FEBRUARY 09, 2022**

Moved by: *John Hetherington*

Seconded by: *[Signature]*

**WHEREAS** the Council of the Municipality receives the correspondence from Matt Foulk, Ghost Gravel Cycling Event revising the route for the 2022 Ghost Gravel Cycling Event approved by motion 2021-364;

**AND WHEREAS** the new route will follow Highway 124 from South river, to River Road, to Highway 520 back to Old Nipissing Road with the rest stop to be set up at the Magnetawan Centennial Park;

**NOW THEREFORE BE IT RESOLVED** that the Council of the Municipality of Magnetawan supports the Cycling event to be hosted on Saturday August 20, 2022 at no charge with the following conditions;

- Approval from the Ontario Cycle Association is granted
- No roads will be blocked and cyclists will not impede the flow of traffic
- Insurance indemnifying the Municipality in the amount of \$5,000,000 is submitted to the Clerk prior to the event
- The advertisements reflect that the rest stop is in Magnetawan, ON
- All applicable COVID-19 guidelines must be followed

Carried ✓ Defeated \_\_\_\_\_ Deferred \_\_\_\_\_

*[Signature]*  
Sam Dunnett, Mayor

Recorded Vote Called by: \_\_\_\_\_

Recorded Vote

| Member of Council   | Yea | Nay | Absent |
|---------------------|-----|-----|--------|
| Brunton, Tim        |     |     |        |
| Hetherington, John  |     |     |        |
| Kneller, Brad       |     |     |        |
| Smith, Wayne        |     |     |        |
| Mayor: Dunnett, Sam |     |     |        |



*Knowing our heritage  
we will build our future*

Moved by: \_\_\_\_\_

Seconded by: \_\_\_\_\_

**WHEREAS** the Council of the Municipality receives the correspondence from Chris Barry and Alaina Cawston, Magnetawan Gazebo July 2022;

**AND WHEREAS** Council previously passed resolution 2019-371 approving the use of the Magnetawan Gazebo in September 2020 for 50 people and due to the COVID-19 pandemic the wedding was postponed;

**NOW THEREFORE BE IT RESOLVED THAT** the Council of the Municipality of Magnetawan congratulates Chris Barry and Alaina Cawston on their upcoming marriage and is in agreement with allowing the Magnetawan Gazebo to be used for their nuptials with the understanding that the park will remain open to the public, no signs will be removed from the park area, and a chair rental and delivery fee of \$100.00 plus HST is to be paid.

Carried \_\_\_\_\_ Defeated \_\_\_\_\_ Deferred \_\_\_\_\_

\_\_\_\_\_  
Sam Dunnett, Mayor

Recorded Vote Called by: \_\_\_\_\_

Recorded Vote

| Member of Council   | Yea | Nay | Absent |
|---------------------|-----|-----|--------|
| Brunton, Tim        |     |     |        |
| Hetherington, John  |     |     |        |
| Kneller, Brad       |     |     |        |
| Smith, Wayne        |     |     |        |
| Mayor: Dunnett, Sam |     |     |        |

Tues Feb 22 2022

Good Morning Council

My fiance and I are planning our wedding for July 9 2022, we would like to get married at the Centennial Park, under the gazebo.

We have 70 guests and our wedding is planned for 1pm

We also wanted to know if you provide chairs, and take down signs and chairs

Alicia & Chris

**RESOLUTION NO. 2019 - 371 NOVEMBER 27, 2019**

Moved by: \_\_\_\_\_

Seconded by: \_\_\_\_\_

BE IT RESOLVED THAT the Council of the Municipality of Magnetawan congratulates Chris Barry and Alaina Cawston on their upcoming marriage and is in agreement with allowing the Magnetawan Gazebo to be used for their nuptials with the understanding that the park will remain open to the public and a chair rental and delivery fee of \$100.00 plus HST is to be paid.

Carried  Defeated  Deferred

\_\_\_\_\_  
Sam Dunnett, Mayor

Recorded Vote Called by: \_\_\_\_\_

Recorded Vote

| Member of Council   | Yea | Nay | Absent |
|---------------------|-----|-----|--------|
| Brunton, Tim        |     |     |        |
| Hetherington, John  |     |     |        |
| Kneller, Brad       |     |     |        |
| Smith, Wayne        |     |     |        |
| Mayor: Dunnett, Sam |     |     |        |



*Knowing our heritage  
we will build our future.*

NOV 18 2019

Dear Magnetawan Town Council **RECEIVED**

Thank you for taking the time to consider our request. We are planning our wedding and would love to be able to hold the ceremonies at the beautiful Magnetawan Park on September 26<sup>th</sup>, 2020 at 2 pm.

We expect the ceremonies themselves will take less than an hour in total. However would need some additional time for decorating and cleanup. Our request for Park time would be from 11am to 3pm.

We would like the gazebo for an altar & the immediate surrounding area to seat our guests. (Mostly grass space between gazebo & North East parking lot.)

The ceremonies will be intimate with a maximum of 50 of our closest friends & family.

We expect about 40 people really. We would like to rent some chairs for our guests if they're available. (40-50 chairs max.) Please let us know if that is possible, how much it would cost and when & how to pick them up. We will not be erecting a tent, so hopefully the weather is good! We hope this is workable for council & the town of Magnetawan. We are very excited to be getting married & would be very nice to be wed close to home at our favorite waterfront park!!

Yours Truly Chris Barry & Alaina Cawston

Once again, thank you for your consideration.  
(Contact info is on the back.)







# Community Safety and Well-Being Plan



Almaguin Highlands

2021 - 2025



# TABLE OF CONTENTS

- Introduction.....3
- Community Background .....4
- 1. Why a Community Safety and Well Being Plan? .....5
- 2. Community Engagement .....6
- 3. Priority Risks.....7
- 4. Almaguin Advisory Committees.....9
- 5. TASK FORCES and Members .....9
- 6. Plans to Address Priority Risk ..... 11
- \_\_Priority Risk #1: Physical Health, Access to Healthcare Providers ..... 11
- Priority Risk #2: Access to Services ..... 12
- Priority Risk #3: Employment Opportunities ..... 13
- 7. STAKEHOLDERS CALL TO ACTION  
    **Error! Bookmark not defined.**
- 8. Community Safety and Well-Being Planning Governance Structure ..... 17
- 9. Conclusion..... 18

## INTRODUCTION

---

This Community Safety and Well-Being Plan has been developed on behalf of the communities located within Almaguin Highlands region. It is intended to guide local partners involved in the community safety plan and well-being planning process. It summarizes the work that has been undertaken in the development of this plan.

This plan is a living document and will be updated as communities move forward in their work in continuing its commitment to the safety and well-being of its communities. While this plan is in and of itself valuable, the most important part is for planning partners to stay organized and inform collaborating communities of identified area priorities. The most valuable outcomes from this process is to continue improved coordination of services, collaboration, information sharing and partnerships between local government, agencies and organizations and an improved quality of life for community members.

### **Municipalities involved in this plan throughout Almaguin Highlands:**

Township of Armour  
Village of Burk's Falls  
Township of Joly  
Township of Kearney  
Municipality of Magnetawan  
Township of McMurrich/Montieth  
Township of Perry  
Municipality of Powassan  
Township of Ryerson  
Township of South River  
Township of Strong  
Village of Sundridge

### **Coordinator(s):**

Nicky Kunkel, Clerk Administrator, Village of Burk's Falls  
Melinda Torrance, Deputy Clerk, Township of Perry

## COMMUNITY BACKGROUND

The community of Almaguin Highlands has a combined population of 15,866, the largest population is the age group between 15 and 64 years old, and the least populated age group is 85+ years old. 61.2% of the population are in the working age group between 15 to 64 years old.

Most residents in Almaguin Highlands are married, with the remainder of the population being single or in common-law relationships; there is also a presence of divorced and widowed households. Most of the land is residential, while other land is seasonal cottages. There is a smaller portion with several retail businesses in downtown cores. Households in Almaguin Highlands have an average annual income of \$54,120.

| Stats Canada 2016 Census       |            |                                   |                        |
|--------------------------------|------------|-----------------------------------|------------------------|
| Municipality                   | Population | Median Total Income of Households | Age %                  |
| Township of Armour             | 1,414      | 59,648                            | 27.6% (65 yrs + older) |
| Village of Burk's Falls        | 981        | 40,288                            | 60.7% (15-64 yrs)      |
| Township of Joly               | 304        | 50,816                            | 63.9% (15-64 yrs)      |
| Town of Kearney                | 882        | 56,661                            | 62.1% (15-64 yrs)      |
| Municipality of Magnetawan     | 1,390      | 54,336                            | 59.4% (15-64 yrs)      |
| Township of McMurrich/Monteith | 824        | 54,272                            | 65.5% (15-64 yrs)      |
| Township of Perry              | 2,454      | 58,069                            | 65.4% (15-64 yrs)      |
| Municipality of Powassan       | 3,455      | 66,133                            | 59.2% (15-64 yrs)      |
| Township of Ryerson            | 648        | 57,344                            | 60% (15-64 yrs)        |
| Township of South River        | 1,114      | 40,576                            | 62.8% (15-64 yrs)      |
| Township of Strong             | 1,439      | 60,672                            | 59.4% (15-64 yrs)      |
| Village of Sundridge           | 961        | 50,624                            | 54.7% (15-64 yrs)      |

## 1. WHY A COMMUNITY SAFETY AND WELL BEING PLAN?

The Province’s *Police Services Act* was amended January 1, 2019 to mandate every municipality in Ontario have a “community safety and well being plan”. The Plan was created using a collaborative multi-sectoral approach recognizing that it is more than crime that sets the safety and well being in a community. The ultimate goal is to address root causes to circumstances creating the emergency response for residents. This achievement would then focus on enhancing social development and prevention tools and mitigating risks before they become emergencies. It is an ambitious goal that all stakeholders aspire to achieve. The creation of this document and the continuing update and work that will result from it will be a great step in realizing true community safety and well being in Almaguin.

### Social Development Chart and Well Being Matrix



The Plan had been in the process prior to legislative changes as Almaguin communities and agencies realized early that change in service delivery and working in a more unified manner would assist all residents.

#### Impact of COVID 19

COVID 19 is a global pandemic that resulted in the Province of Ontario declaring a state of emergency and throughout this period has placed restrictions on gatherings and public meetings for the safety of all Ontarians.

The pandemic will have a direct long-term affect on Almaguin and services as well. There is increased anxiety, widespread community closures, job losses and social disruptions including on-line learning, limits on gatherings, and a new sense of caution for everyone’s health.

The agencies and communities working to create this Plan all adjusted their service delivery to continue providing the necessary resources to Almaguin residents. However, it has also increased workloads and affected abilities for contributions to non-urgent assignments. Each partner does recognize the importance of the document and has done their best to ensure their voice is heard and will continue to be heard as the implementation of recommendations and relationships between agencies grow.

## 2. COMMUNITY ENGAGEMENT

---

### Early Consultations

To support the identification of local risks, partners involved in the development of the Almaguin Highlands Community Safety and Well Being Plan hosted community engagement sessions within their own municipalities. The Village of Burk's Falls hosted a community action stakeholders team meeting in 2015. The main issues identified by the school board were learning behaviours, violent outbursts, broken homes and parenting conflicts, as well as not enough funding for after school programs or high school programs. In addition, the team meeting identified an increase in drug addiction, a shortage of affordable housing, and poverty and hunger in families.

The Township of Perry hosted two meetings one in 2015 with community involvement and a secondary meeting in 2016 with agency stakeholders. The first session had approximately 40 participants that included representation from a variety of agencies/organizations across a wide range of sectors and members of the public. The open discussion revealed concerns of risk areas as being, email/telephone scams and cybercrime, underemployment in the vulnerable sector, assistance for victims of male abuse and community patrol/neighbourhood watch. The secondary session with stakeholder agencies held in 2016 was not open to the public. It was initiated to better understand how municipalities can assist in the needs of the various agencies and to encourage more communication and collaborate on identified matters within each agency.

There was a lot of discussion surrounding mental health and the effects it has on the number of calls the OPP and Huntsville Hospital handle. Representatives from the OPP also disclosed the need for community mobilization and working together with other agencies to identify issues and develop strategies for long term solutions for those with mental health issues or those who experience victimization.

### Service Provider Consultation

While it is the municipalities steering the development of the Plan, our role is to facilitate as we do not provide direct services. However, as you will see further along, there is a role for councils to mitigate risks moving forward.

In 2019 as the Almaguin municipalities began to work together to create the full Community Safety and Well Being Plan. A survey was sent to all agency stakeholders to update the issues and concerns they are experiencing to find common themes and identify emerging issues. A summary of the results is attached in the appendix.

## Public Consultation

What the community depicts as concerns is equally as important as the municipalities and the agencies who are addressing the known and on-going issues in the region.

The survey asked questions regarding: safety, security and crime; physical and mental health; experience with substance abuse; opinions on quality of life and employment information. A copy of the survey is available in the Appendix.

The survey was available to every resident in Almaguin. There was an on-line component through Survey Monkey as well as hard copies available for pick up/completion in each municipality. The survey, while anonymous, asked each participant to identify where they live, their gender, age and other demographic information. From this we know the majority of the respondents at 73% were married females aged between 36 and 55 and 86% of the respondents were permanent residents.

Residents provide a different perspective and can highlight where people are struggling or when plans and policies are already working to mitigate issues. The agency results does include areas that the residential survey does not include and vice versa. However, there are some common themes identified as well and that will be the focus of the Plan.

## 3. PRIORITY RISKS

---

The risks identified throughout this Plan were selected through the stakeholder and community surveys. Seven agency stakeholders submitted statistics, emerging trends, current programs and problems they viewed as needing assistance with.

The community survey resulted in a total of 444 responses. There were 34 multiple choice questions where some questions allowed for written comments. The surveys were sorted by municipality along with the top safety and well-being items the communities felt were of the most important.

The top three (3) community concerns that closely related to agency stakeholder concerns will be a focus in this first four year plan.

### Top 3 Community Safety and Well-Being Priorities

#### 1. *Physical Health, Access to Healthcare*

- 49.04% respondents rated the most important safety and well-being priority was the lack of healthcare physicians and services within the Almaguin region. There was an outstanding amount of concern with the fact that there are not enough doctors in our areas. Quite a number of individuals do not have a family doctor that is close or do not have a family doctor

at all. Other responses included having no access to walk in clinics or health resources such as nurse practitioners, optometrists, dentists, therapists, labs, etc.).

## 2. Access to Services

- A majority of responses were related to the lack of access to healthcare services and supports. 123 responses out of 444 represented 32.63%, indicating that program and clinic location has impacted their ability to receive proper physical or mental health supports. Lack of local mental health support or long wait times to get into counselling services were also expressed. There were a minimal number of responses for access to a gym, summer/camp activities for children and indoor recreational programs.

## 3. Employment Opportunities

- The majority of answers regarding employment were either full time workers or retired. Of those that are currently unemployed, lack of opportunity and location were the most prominent factors that were preventing people from finding a job. Precarious employment and insufficient opportunities are also a concern. Opportunities for youth employment were also reported as lacking.

Further priority risk factors that are common between stakeholders with a stronger rating from agencies are;

## 4. Affordable Housing

- Comments from both agency and the community surveys in 2019 expressed concerns regarding affordable housing. Whether the housing is rental or ownership, shelter is clearly a necessary item that improves many of the social development and community well being.

## 5. Services to Youth and Education Institutions

- In discussions, it is clearly evident that youth are affected by the factors of social development from an early age. These factors may affect ability to learn and to focus in class. It is important to identify youth who need assistance early to provide them with the best opportunities for success.

There are common social denominators, Province wide, that are widely known to effect one's development and quality of life. These are mental health, substance abuse, and violence. It is interesting to note that while agencies in Almaguin placed these among the higher rated issues that they respond to, the community survey results did not rank them high. Out of 27 issues asked to be ranked in the survey the community ranked personal safety as 9<sup>th</sup> and mental health and substance abuse as 15<sup>th</sup> and 22<sup>nd</sup> with domestic violence as 19<sup>th</sup> overall.



It is suggestive that as the top 5 priorities become addressed and people are finding security when those factors are resolved, that the response for mental health and protective services will be relatively reduced.

## 4. ALMAGUIN ADVISORY COMMITTEES

---

An Almaguin Advisory Committee was formed to delve into the issues and concerns of various stakeholders within our communities. Meetings will continue to be held to address new and continuous concerns and collaborate on ideas to assist each other. The advisory committee membership consisted of:

- Dominic Lalonde, Ontario Provincial Police
- Megan Wagué, Local Health Integration Network
- Jayme Young, District of Parry Sound Social Services Administration Board
- Laurie Macdonald, Canadian Mental Health Association, Muskoka Parry Sound
- Al Bottomley, Near North School Board, Trustee (representing Almaguin)
- Gisele Hebert, Children's Aid Society of the District of Nipissing and Parry Sound
- Nicky Kunkel, Village of Burk's Falls
- Melinda Torrance, Township of Perry

## 5. TASK FORCE AND MEMBERS

---

In addressing the top community priorities identified by the survey the Advisory Committee also established two task forces to gain more insight into the issues of Almaguin. These two task forces met as needed to identify needs with the community and provide recommendations on how to mitigate the concerns as they were expressed.

### A. Physical Health, Access to Healthcare (Priority 1 and 2)

#### Health Advisory Task Force

- **Purpose:** to discuss priority one (1) and two (2) regarding how to attract and retain physicians within Almaguin Highlands and to address healthcare issues with a regional approach.

- **Membership:** the healthcare task force included representation from various sectors within the health field. Specifically, the taskforce consisted of:
  - Kevin MacLeod, Burk's Falls Family Health Team
  - Megan Wagué, Local Health Integration Network
  - Dr. Dan Pessotto, South River
  - Marianne Stickland, Almaguin Ontario Health Team, Sundridge Medical Centre
  - Councillor Rod Ward (Armour Township), Almaguin Highlands Health Council
  - Jeanette Smith, Almaguin Community Economic Development
  - Dominic Lalonde, Ontario Provincial Police

#### Employment Opportunities (Priority 3)

##### **Employment Advisory Task Force**

- **Purpose:** to discuss the lack of employment opportunities and collaboratively approach ideal solutions for the Almaguin Highlands community.
- **Membership:** this group includes representation from various stakeholder and agency groups whose mandate aligns with this group's purpose. Specifically, membership consisted of:
  - Jessica Busch, Women's Own Resource
  - Stacey Fidler, Labour Market Group
  - Romano Marchi, Agelic
  - Jennifer Farquhar, Almaguin Chamber of Commerce
  - Dave Gray and Jeanette Smith, Almaguin Community Economic Development
  - Jeff Degagne, Ontario Works
  - Luke Preston, Employment North - Sundridge
  - Dominic Lalonde, Ontario Provincial Police
  - Nicky Kunkel, Village of Burk's Falls
  - Melinda Torrance, Township of Perry

## 6. PLANS TO ADDRESS PRIORITY RISK

---

### Priority Risk #1: Physical Health, Access to Healthcare Providers

A large amount of the population within Almaguin Highlands is without access to primary healthcare physicians and healthcare services. As a result, individuals have been on long waiting lists to obtain a family physician in the limited areas where physicians are located. Additionally, the Almaguin Highlands has not attracted several other healthcare services that are provided in larger centers. Residents have to travel long distances for specialist consultations, treatments, nurse practitioners and even walk-in clinics.

**Vulnerable Group:** infants, children, young families and seniors

**Risk Factors:** undiagnosed ailments, lack of primary care

**Protective Factors:** positive medical outcomes, healthcare support services, transportation service increases

**Activities:**

- Broker partnerships between healthcare professionals within Almaguin Highlands
- Expansion of services for after hours
- Engagement sessions involving agency stakeholders
- Meetings held every three months with healthcare committees, physicians, local health networks
- Review outcomes of physician recruitment process to consider amending and enhancing procedures
- Implement transportation services

**Immediate Outcomes:**

- Community is better informed of issues faced related to community safety and well-being (healthcare and employment specifically)
- Impacts of not receiving immediate healthcare, all age groups affected, continued communication with service providers, agencies and stakeholders
- Increased access to healthcare and transportation
- A coordinated approach to supporting the efforts of the advisory groups who are helping to bring primary care to our region

**Intermediate Outcomes:**

- Increase access to physicians

**Long-Term Outcomes:**

- Increase community safety and well-being through an increase in healthcare services

**Priority Risk #2: Access to Services**

The lack of transportation continues to affect all age groups within Almaguin Highlands. Seniors do not have the ability to leave their houses to do simple everyday tasks. Youth, young and middle age citizens are at risk of not gaining employment. There is no access to healthcare services for those that may need to travel to different centers (for OTN or to obtain specialist appointments).

**Vulnerable Group:** infants, children, young families and seniors

**Risk Factors:** poor mental health, loneliness, low self-esteem, impulsivity

**Protective Factors:** self-esteem, adaptability, access to/availability of resources, professional services and social supports

**Activities:**

- Broker partnerships between municipal and ride-hailing companies (Uber, Lyft)
- Engage local businesses to commence a ride-share committee. Possible to have volunteers pick up new or existing employees/residents requiring transportation
- Participating municipalities promote Carpool Almaguin parking lots – consider digital options for promotion and ride sharing linking, etc.
- Communicate with busing companies inquiring about the use of school buses outside of start and end times for school
- Continued support in economic development
- Create a website for ride-share options

**Immediate Outcomes:**

- Job employability increases
- Individuals are able to get the healthcare services they require
- Seniors will be provided opportunities to be independent and socialize

**Intermediate Outcomes:**

- The level of service availability meets the needs of the population

**Long-Term Outcomes:**

- Increase community safety and well-being through an increase in healthcare and employment services. Will also greatly increase social interaction and provide an avenue for independence

**Priority Risk #3: Employment Opportunities**

There is a disconnect between employers and people seeking employment in and around Almaguin Highland region. The current COVID-19 pandemic is inhibiting job seekers as the government supplies CERB and Employment Insurance which strengthens the lack of motivation. There is a declining population with not enough people to fill job vacancies and larger centers have larger projects thereby bringing in more people. The lack of transportation is also a defining factor for people not being able to commute between home and job sites.

**Vulnerable Group:** teens, young to middle income families

**Risk Factors:** lack of opportunities for young people possibly leading them to addictions or crime, not knowing whether bills can be paid can lead to emotional instability/stress/anxiety

**Protective Factors:** self-esteem, positive relationship with family and friends, stability of the family unit, opportunities for youth and young families

**Activities:**

- Engage multiple business meetings seeking what employers are looking for and assisting them with job applicant opportunities
- Implementation of settlement and retention strategy – integrate immigration into placements and assist in finding housing
- Implement strategies for advertising and promoting outside the Almaguin Highlands region
- Engage high school students asking them what they are seeking and how employment services can assist

**Immediate Outcomes:**

- Increase in self-awareness and pride
- Ability to self-sustain
- Connecting individuals with skills to appropriate jobs

**Intermediate Outcomes:**

- Job seekers are provided with the support they require to obtain gainful employment with the assistance of employment programs

**Long-Term Outcomes:**

- Increase community safety and well-being with job stability and housing

## 7. STAKEHOLDERS CALL TO ACTION

---

There are several actions that all stakeholders can do to improve the safety and well being of Almaguin communities. Only by working together can the activities and goals outlined be realized.

### 1. Advocate

Having an understanding of what the community and the service agencies consider to be the issues in Almaguin better prepares each stakeholder to advocate for change. Chronic underfunding and staffing issues are identified as issues actively affecting Almaguin.

Municipal councils can advocate and support increased funding when meeting with senior levels of government for health care services. There are several existing groups in the region who are working toward increasing access to services such as the East Parry Sound Community Service (Eastholme), Almaguin Highlands Health Council, and doctors and Family Health Teams. When councils are deciding policies, they can consider the priorities listed to ensure they are being proactive in the resolution. For instance, when reviewing official plans they can create policies regarding affordable housing, secondary units, where growth will be focused to mitigate transportation barriers and when developers approach to build subdivisions or multi-residential units agreements can be created to ensure some affordable units are made available. Creating and supporting volunteer programs/organizations and opportunities can provide residents with new skills that can be transferred to employment positions. Supporting businesses and new start-up companies and ensuring they have access to regional resources improves the overall economy.

### 2. Communication and Awareness

Open and two-way communication is necessary to informing advocacy as well as ensuring efforts are collaborative and not duplicating efforts. While it may be inevitable, like minded groups working toward the same goals can share notes/minutes with councils and other agencies to augment efforts instead of straining limited resources. This could be the creation of quarterly or semi-annual meetings between similar organizations (health committees, education services) to discuss new trends and emerging issues. Some such communities exist, such as HOME, the AHHC, and the OPP/Mental Health Protocols. Only by championing additional collaboration can better mitigation and prevention be obtained.

Equally important is the ability for residents to have open dialogue with all stakeholders. Transparency, accountability and creating the awareness for residents to become involved and have a voice will garner trust and with intention allow people to seek assistance.

Just as the local well being services and agencies will develop more collaboration opportunities, it is important to ensure all municipal officials and stakeholders know there are resources available to them now. While Almaguin may be underserved, it is not void of services. In the Appendix is a list of services within the region. It is important to know who to call. When it is urgent with an active crisis call 911. If the situation allows, call 211 for the right service contacts. The awareness of what assistance is available is a critical step to improving everyone's safety and well being.

### 3. Data Collection

It was evident in the preparation of this Plan that Almaguin specific data is not well kept by all agencies. Many local services are based regionally and have statistics for the head-office but not at the local levels that are easily obtainable. It is time consuming to track responses that become consumed in larger reporting requirements. It is important that any local office also keep statistics and bench marking tools for the Almaguin area. In trying to determine what affordable housing looks like, agencies do not keep a list of area rental rates to gauge market values in Almaguin. Canadian Mortgage and Housing Corporation does not have a figure for affordable rent between Parry Sound, Nipissing and Muskoka. Almaguin is combined, yet a very different community than the rest. This, then means, any developer has to complete their own study which may be a deterrent to providing affordable housing. When sitting on agencies, boards and communities, council members can advocate for better data collection opportunities.

### 4. Cooperation

The safety of Almaguin can be gauged by the calls for service by the Almaguin OPP Detachment. It will be necessary to implement key strategies to mitigate victimization. Speeding, impaired and distracted driving on roadways and ATV/Snowmobile trails is a concern and education programs are in place to prevent these occurrences. Municipalities can assist by sharing information on social media platforms, really from all agencies that service Almaguin.

The Almaguin OPP works with the Muskoka Health Centre to streamline intake protocols, the Canadian Mental Health Association through co-response and intervention teams and they participate in a program with the District of Parry Sound Social Services for homelessness. The Almaguin Detachment Commander is required to draft a three (3) year action plan and posts an annual update on OPP.ca. The local statistics on calls-for-service identify the priorities and action steps to mitigate the most urgent of matters in Almaguin.

Community Policing Boards are being creating by the Province and the Almaguin Detachment will have a Board as already determined by the municipalities to the Solicitor General. The next step for this initiative is expected early 2022. It will take this cooperation

among the OPP, municipalities, and the social agencies to bring meaningful change to Almaguin residents.



## 8. COMMUNITY SAFETY AND WELL-BEING PLANNING GOVERNANCE STRUCTURE

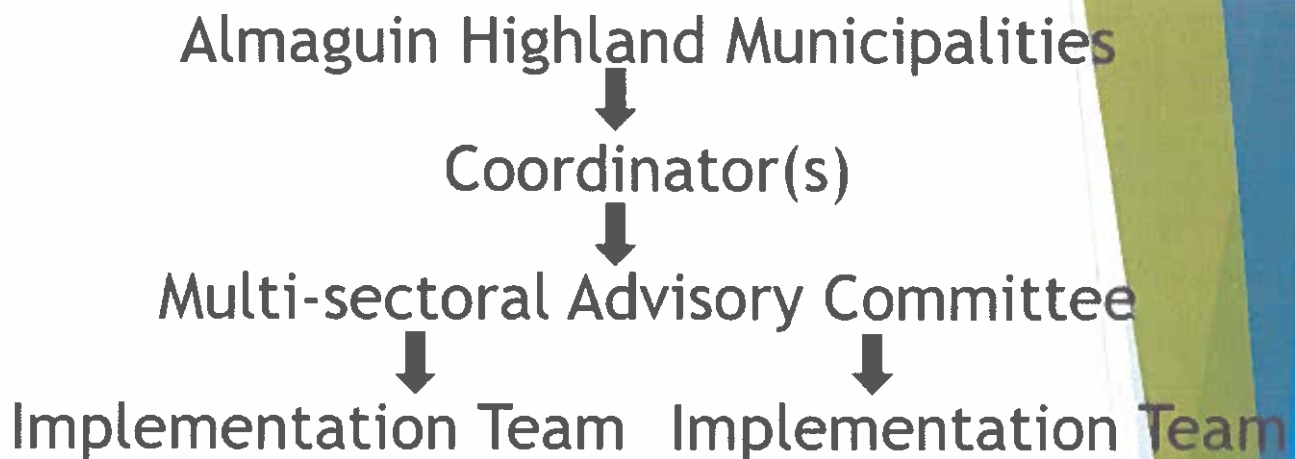

- ▶ Commitment from local governance
  - ▶ Obtained multi-sectoral buy-in
  - ▶ Community is engaged
  - ▶ Advisory Group formed
  - ▶ Healthcare and Employment Task Forces formed
- ▶ Risks are identified and prioritized
  - ▶ Key stakeholders meet
  - ▶ Plan is reviewed
- ▶ Plan is finalized and released publicly

## 9. CONCLUSION

---

The Almaguin Highlands Community Safety and Well-being Plan (CSWB) Plan establishes a framework and coordinated approach to working alongside system partners to continue promoting safety and well-being for all residents within our region. As agencies and stakeholders move into implementation, progress will be tracked with monitoring and evaluation through continuous meetings with the advisory groups and municipal partners. Throughout the 4-year course of the plan and in future iterations, we will continue to be responsive to emerging needs in our communities and create ongoing opportunities for community engagement and involvement.

With the combined efforts of our community stakeholders, we would like to thank the following:

- Megan Wagué, Local Health Integration Network
- Jayme Young, District of Parry Sound Social Services Administration Board
- Gisele Hebert, Children's Aid Society of the District of Nipissing and Parry Sound
- Dominic Lalonde, Ontario Provincial Police
- Kevin MacLeod, Burk's Falls Family Health Team
- Megan Wagué, Local Health Integration Network
- Dr. Dan Pessotto, South River
- Marianne Stickland, Almaguin Ontario Health Team
- Councillor Rod Ward (Armour Township), Almaguin Highlands Health Centre
- Jessica Busch, Women's Own Resource
- Stacey Fidler, Labour Market Group
- Romano Marchi, Agelic
- Jennifer Farquhar, Almaguin Chamber of Commerce
- Dave Gray and Jeanette Smith, Almaguin Community Economic Development
- Jeff Degagne, Ontario Works
- Luke Preston, Employment North - Sundridge
- Nicky Kunkel, Clerk, Village of Burk's Falls
- Melinda Torrance, Deputy Clerk, Township of Perry

### Q1 Where do you live?

Answered: 444 Skipped: 1

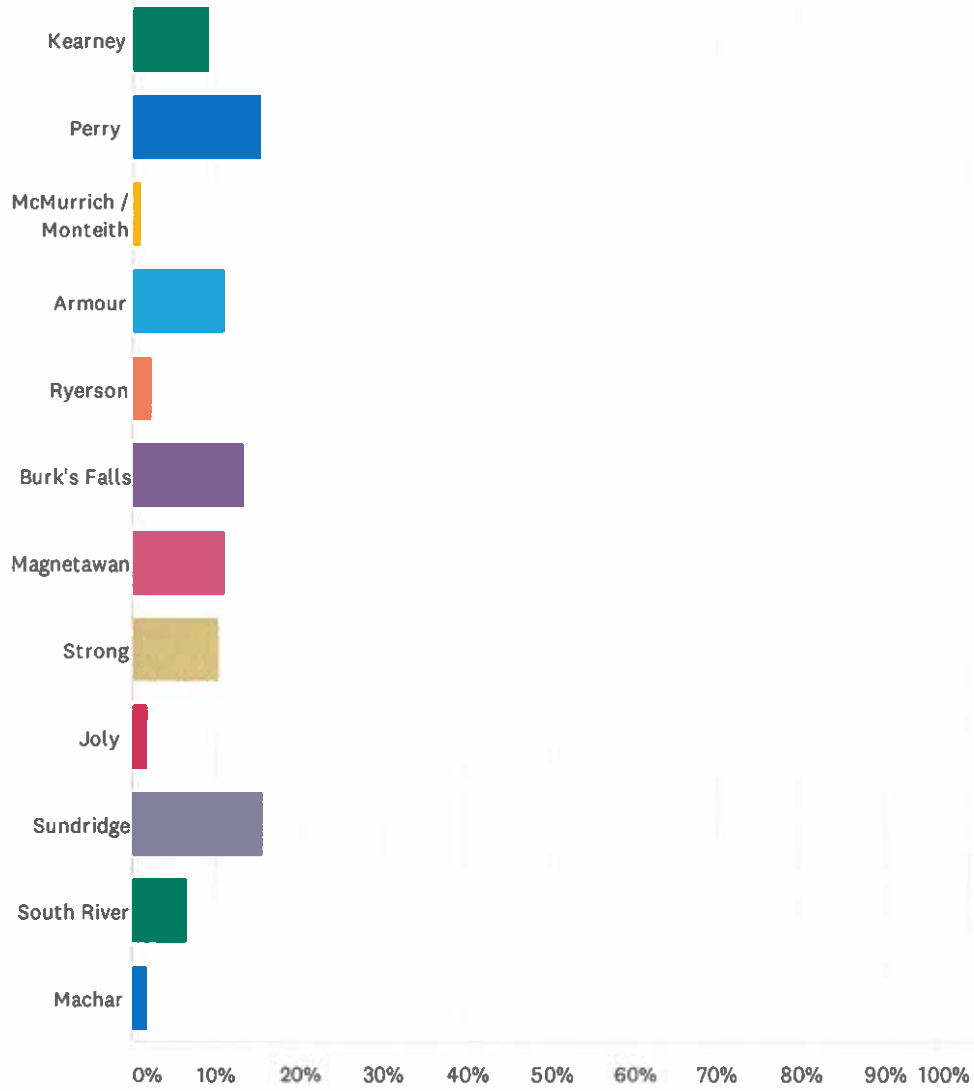

Almaguin Community Safety and Well Being Plan Survey 2020

| ANSWER CHOICES       | RESPONSES |            |
|----------------------|-----------|------------|
| Kearney              | 9.23%     | 41         |
| Perry                | 15.54%    | 69         |
| McMurrich / Monteith | 1.13%     | 5          |
| Armour               | 11.04%    | 49         |
| Ryerson              | 2.25%     | 10         |
| Burk's Falls         | 13.29%    | 59         |
| Magnetawan           | 11.04%    | 49         |
| Strong               | 10.36%    | 46         |
| Joly                 | 1.80%     | 8          |
| Sundridge            | 15.77%    | 70         |
| South River          | 6.76%     | 30         |
| Machar               | 1.80%     | 8          |
| <b>TOTAL</b>         |           | <b>444</b> |

## Q2 What is your age?

Answered: 445 Skipped: 0

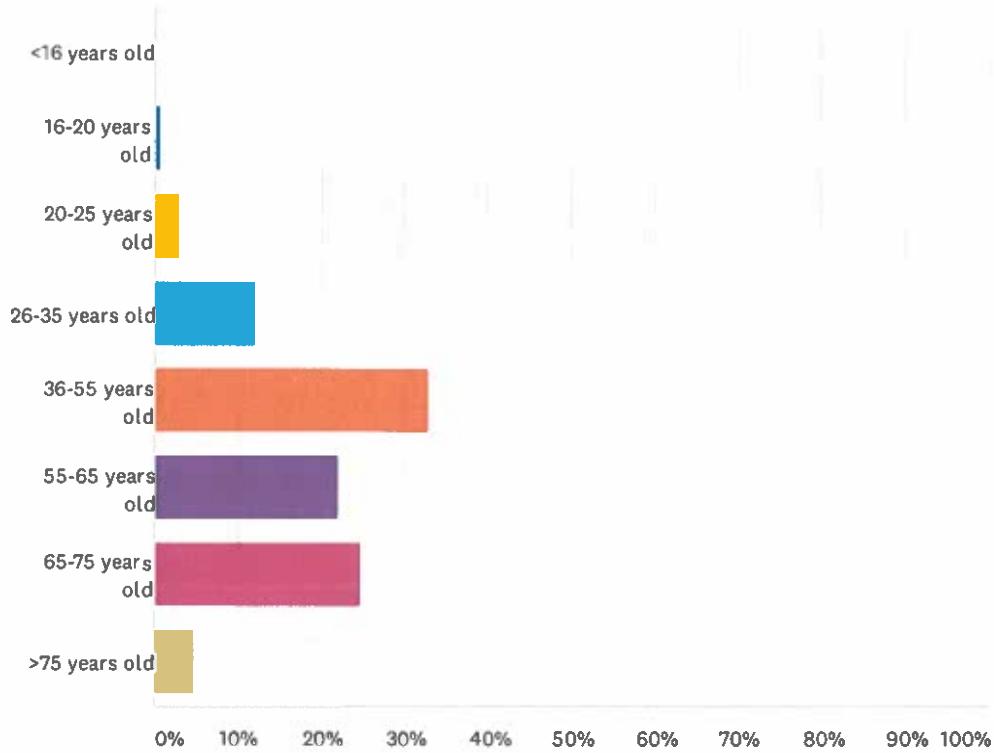

| ANSWER CHOICES  | RESPONSES |            |
|-----------------|-----------|------------|
| <16 years old   | 0.00%     | 0          |
| 16-20 years old | 0.67%     | 3          |
| 20-25 years old | 2.92%     | 13         |
| 26-35 years old | 12.13%    | 54         |
| 36-55 years old | 32.81%    | 146        |
| 55-65 years old | 22.02%    | 98         |
| 65-75 years old | 24.72%    | 110        |
| >75 years old   | 4.72%     | 21         |
| <b>TOTAL</b>    |           | <b>445</b> |

### Q3 What is your gender?

Answered: 445 Skipped: 0

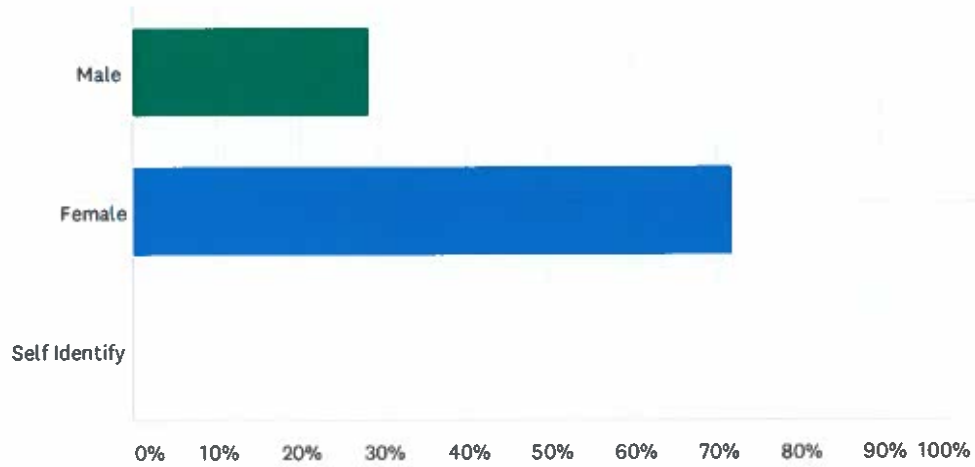

| ANSWER CHOICES         | RESPONSES |     |
|------------------------|-----------|-----|
| Male                   | 28.54%    | 127 |
| Female                 | 71.91%    | 320 |
| Self Identify          | 0.00%     | 0   |
| Total Respondents: 445 |           |     |

| # | SELF IDENTIFY           | DATE |
|---|-------------------------|------|
|   | There are no responses. |      |

### Q4 What is your marital & family status?

Answered: 441 Skipped: 4

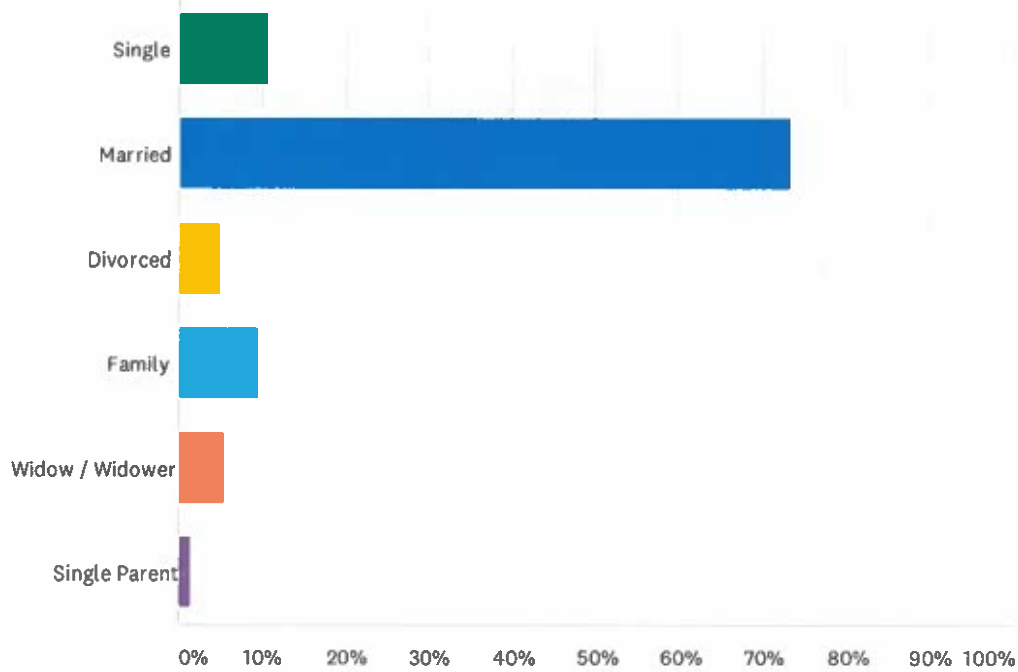

| ANSWER CHOICES         | RESPONSES |     |
|------------------------|-----------|-----|
| Single                 | 10.66%    | 47  |
| Married                | 73.47%    | 324 |
| Divorced               | 4.99%     | 22  |
| Family                 | 9.52%     | 42  |
| Widow / Widower        | 5.44%     | 24  |
| Single Parent          | 1.36%     | 6   |
| Total Respondents: 441 |           |     |

### Q5 Are you a seasonal or permanent resident?

Answered: 440 Skipped: 5

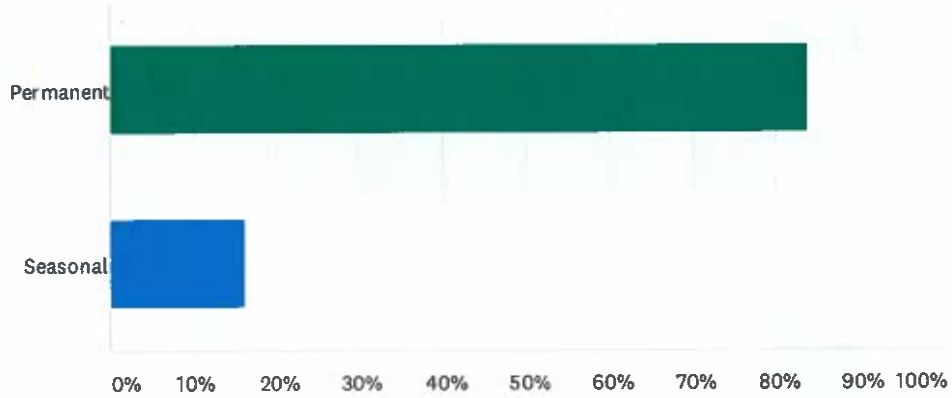

| ANSWER CHOICES | RESPONSES |     |
|----------------|-----------|-----|
| Permanent      | 83.86%    | 369 |
| Seasonal       | 16.14%    | 71  |
| TOTAL          |           | 440 |



### Q6 How do you feel about your personal safety?

Answered: 418 Skipped: 27

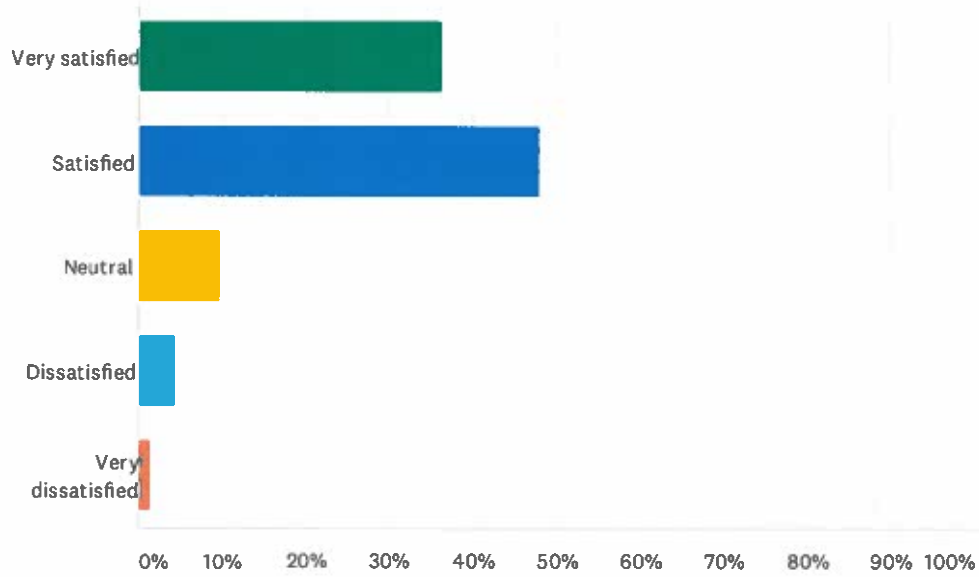

| ANSWER CHOICES    | RESPONSES |            |
|-------------------|-----------|------------|
| Very satisfied    | 36.36%    | 152        |
| Satisfied         | 48.09%    | 201        |
| Neutral           | 9.81%     | 41         |
| Dissatisfied      | 4.31%     | 18         |
| Very dissatisfied | 1.44%     | 6          |
| <b>TOTAL</b>      |           | <b>418</b> |

### Q7 Have you ever felt unsafe due to:

Answered: 420 Skipped: 25

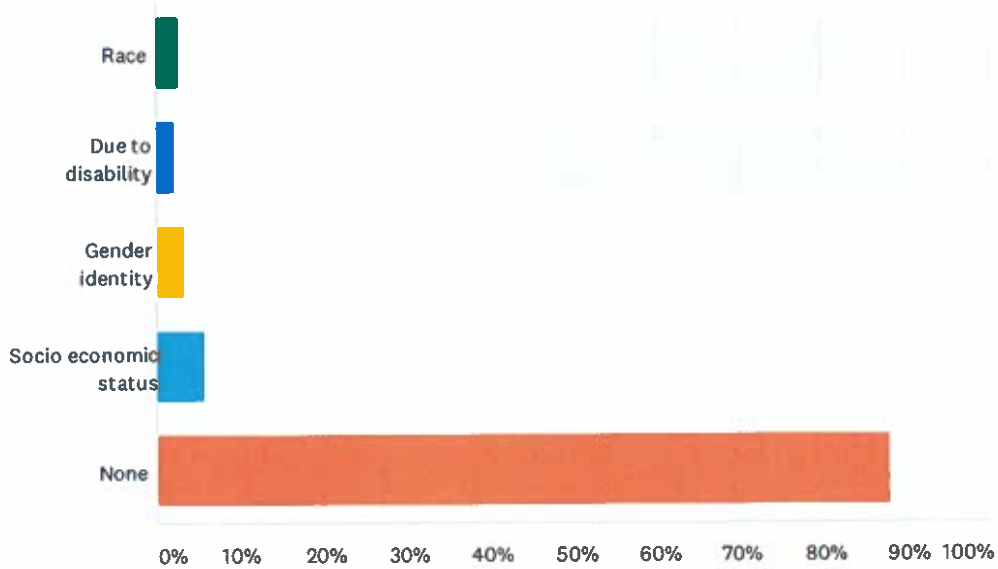

| ANSWER CHOICES         | RESPONSES |     |
|------------------------|-----------|-----|
| Race                   | 2.62%     | 11  |
| Due to disability      | 2.14%     | 9   |
| Gender identity        | 3.33%     | 14  |
| Socio economic status  | 5.95%     | 25  |
| None                   | 88.10%    | 370 |
| Total Respondents: 420 |           |     |

### Q8 I feel my community has adequate policing

Answered: 420 Skipped: 25

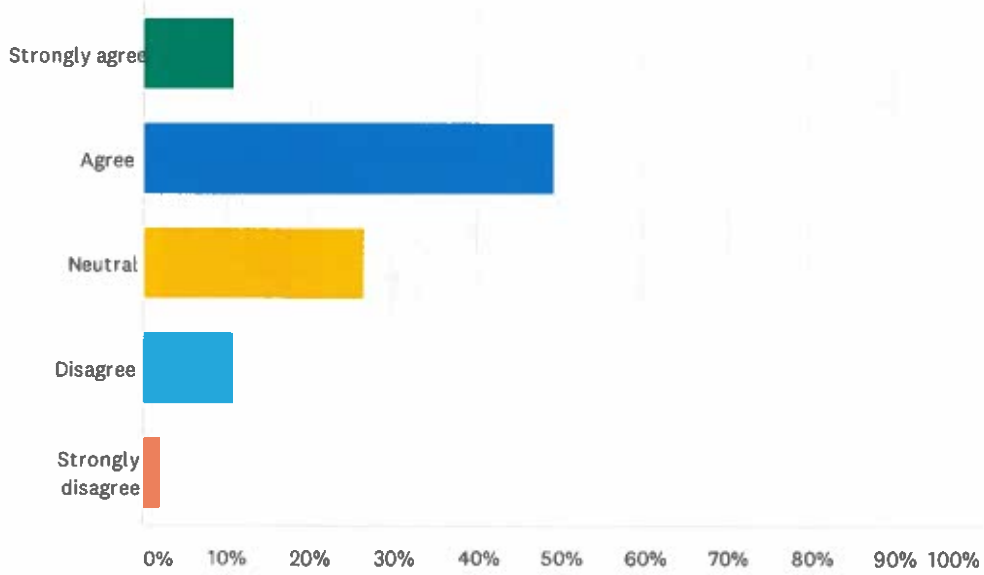

| ANSWER CHOICES    | RESPONSES |            |
|-------------------|-----------|------------|
| Strongly agree    | 10.95%    | 46         |
| Agree             | 49.29%    | 207        |
| Neutral           | 26.67%    | 112        |
| Disagree          | 10.95%    | 46         |
| Strongly disagree | 2.14%     | 9          |
| <b>TOTAL</b>      |           | <b>420</b> |

### Q9 I feel like my community's crime rate is high?

Answered: 420 Skipped: 25

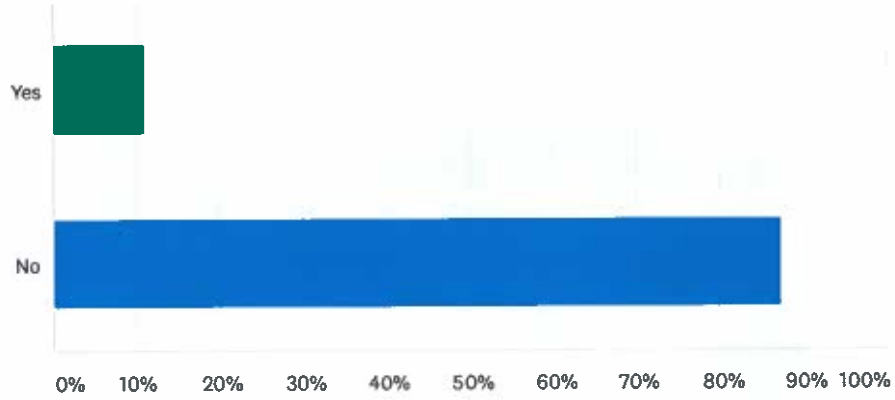

**ANSWER CHOICES**

**RESPONSES**

|              |        |            |
|--------------|--------|------------|
| Yes          | 11.19% | 47         |
| No           | 87.38% | 367        |
| <b>TOTAL</b> |        | <b>420</b> |

Almaguin Community Safety and Well Being Plan Survey 2020

| #  | IF YES, PLEASE SPECIFY WHY                                                                                                                                                                                       | DATE               |
|----|------------------------------------------------------------------------------------------------------------------------------------------------------------------------------------------------------------------|--------------------|
| 1  | Don't know                                                                                                                                                                                                       | 6/7/2020 12:41 PM  |
| 2  | Bullies                                                                                                                                                                                                          | 5/27/2020 8:33 PM  |
| 3  | Not much police presence when there should be                                                                                                                                                                    | 5/27/2020 6:21 PM  |
| 4  | I feel safe in my house and on my property                                                                                                                                                                       | 5/26/2020 5:29 PM  |
| 5  | Theft and illicit drug abuse                                                                                                                                                                                     | 5/26/2020 11:57 AM |
| 6  | Very high no one works for a living so they steal!                                                                                                                                                               | 5/26/2020 9:59 AM  |
| 7  | High speed driving on Eagle Lake Rd. Weekends and evening hours until 1:30 amish                                                                                                                                 | 5/26/2020 8:35 AM  |
| 8  | for break and enters/stolen property and more recently drug busts                                                                                                                                                | 5/26/2020 7:25 AM  |
| 9  | \$15k damage to my property                                                                                                                                                                                      | 5/26/2020 7:22 AM  |
| 10 | Petty crime, yes...no consequences for these                                                                                                                                                                     | 5/25/2020 7:07 PM  |
| 11 | I have ZERO confidence in any aspect local municipal governance                                                                                                                                                  | 5/25/2020 10:04 AM |
| 12 | Drugs, poverty.                                                                                                                                                                                                  | 5/25/2020 9:54 AM  |
| 13 | unsure                                                                                                                                                                                                           | 5/19/2020 7:35 PM  |
| 14 | Alot of break-ins and speeders on town streets                                                                                                                                                                   | 5/17/2020 2:04 PM  |
| 15 | More reactive than proactive                                                                                                                                                                                     | 5/16/2020 6:49 PM  |
| 16 | Drugs are everywhere and nothing is done about it.                                                                                                                                                               | 5/15/2020 6:10 PM  |
| 17 | Unsure                                                                                                                                                                                                           | 5/15/2020 12:59 PM |
| 18 | a lot of break and enters, lots of DUI's, drug busts                                                                                                                                                             | 5/15/2020 12:47 PM |
| 19 | I have ZERO confidence in any aspect of municipal governance                                                                                                                                                     | 5/14/2020 11:07 AM |
| 20 | Drug trafficking                                                                                                                                                                                                 | 5/13/2020 6:39 PM  |
| 21 | don't know                                                                                                                                                                                                       | 5/13/2020 6:36 PM  |
| 22 | Unsure                                                                                                                                                                                                           | 5/13/2020 6:33 PM  |
| 23 | We don't hear about it as we have no tv                                                                                                                                                                          | 5/13/2020 5:43 PM  |
| 24 | more and more reports of crimes in our small towns being reported                                                                                                                                                | 5/13/2020 3:47 PM  |
| 25 | Don't know                                                                                                                                                                                                       | 5/13/2020 12:43 PM |
| 26 | My home has been broken into on one occasion, my car broken into on another occasion and my son's expensive brand new bike stolen on a third occasion. Vehicles speed constantly up Albert street                | 5/13/2020 12:06 PM |
| 27 | Rarely hear statistics but there is a concern                                                                                                                                                                    | 5/13/2020 10:12 AM |
| 28 | Our street has been vandalized separate properties to many times                                                                                                                                                 | 5/13/2020 10:07 AM |
| 29 | Lots of cottage break ins                                                                                                                                                                                        | 5/12/2020 7:09 PM  |
| 30 | Because i see it every day                                                                                                                                                                                       | 5/12/2020 2:01 PM  |
| 31 | Only yes, was when Pub was open                                                                                                                                                                                  | 5/12/2020 1:13 PM  |
| 32 | Takes a considerable amount of time for police to arrive.                                                                                                                                                        | 5/12/2020 12:34 PM |
| 33 | Thefts constantly, kids breaking glass in the road at night, have had multiple things stolen from my property. Have had many things happen that police don't get called to because they don't take it seriously. | 5/12/2020 11:06 AM |
| 34 | poverty, generation abuse, childhood trauma and drug use                                                                                                                                                         | 5/12/2020 8:53 AM  |
| 35 | Drug use                                                                                                                                                                                                         | 5/11/2020 7:51 PM  |

Almaguin Community Safety and Well Being Plan Survey 2020

|    |                                                                                                                                                                                                                                                                |                   |
|----|----------------------------------------------------------------------------------------------------------------------------------------------------------------------------------------------------------------------------------------------------------------|-------------------|
| 36 | Drug grow op in Kearney and police don't do anything                                                                                                                                                                                                           | 5/11/2020 4:59 PM |
| 37 | Even though I said no, I do find at certain times crime rises. Not sure why but just seems that way.                                                                                                                                                           | 5/11/2020 4:52 PM |
| 38 | .                                                                                                                                                                                                                                                              | 5/11/2020 4:43 PM |
| 39 | I love Burk's Falls, and I believe it is a safe community.... however, there is a huge substance abuse problem in our region that I feel is not being taken seriously enough. I think our community is in desperate need of more funding for support services. | 5/11/2020 4:29 PM |
| 40 | Look through social media and you'll see the unreported thefts and vandalism                                                                                                                                                                                   | 5/11/2020 4:06 PM |
| 41 | Prescription drug use is very high, and many low income families                                                                                                                                                                                               | 5/11/2020 3:39 PM |

### Q10 What are the top 5 most important safety and well-being priorities to you?

Answered: 416 Skipped: 29

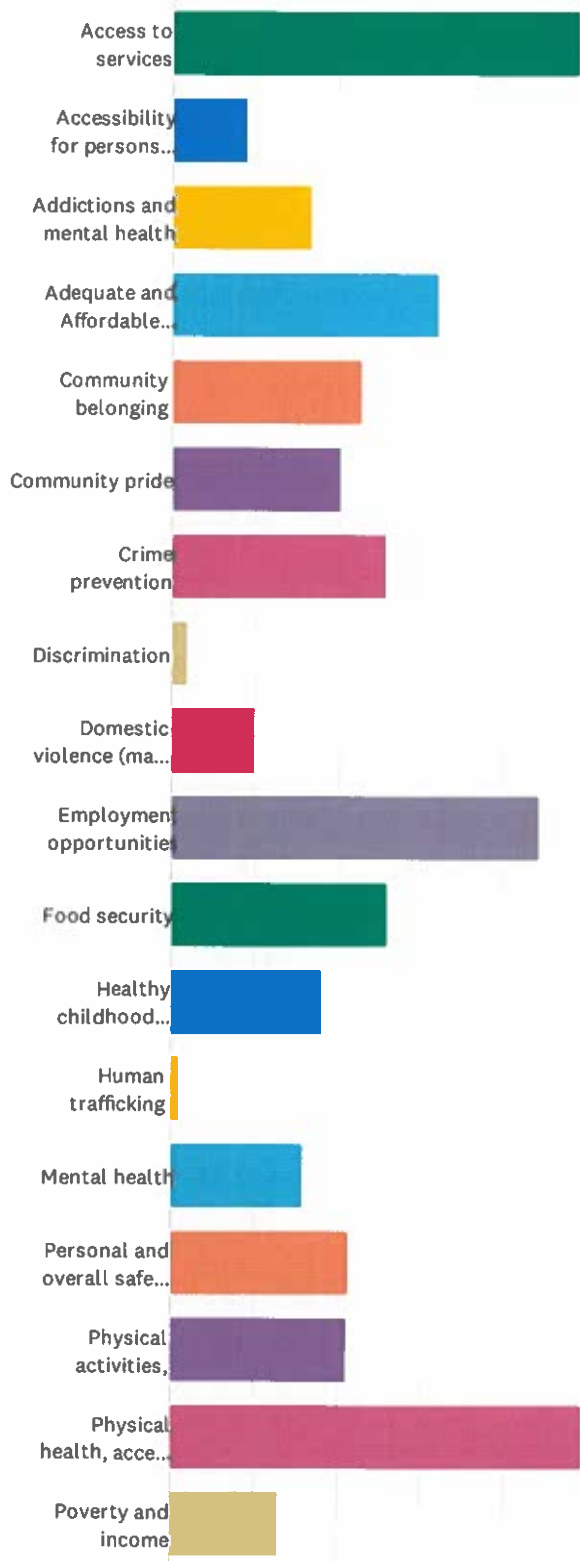

Almaguin Community Safety and Well Being Plan Survey 2020

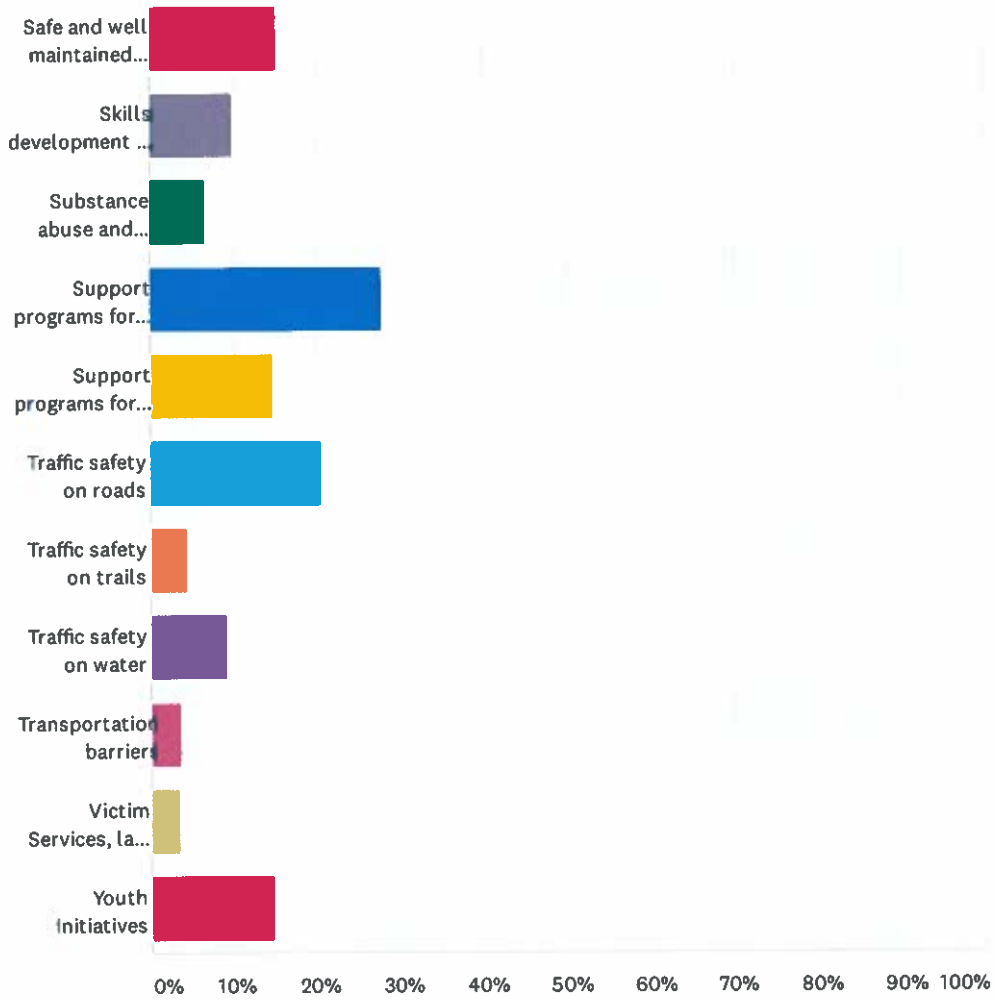



Almaguin Community Safety and Well Being Plan Survey 2020

| ANSWER CHOICES                                                | RESPONSES |     |
|---------------------------------------------------------------|-----------|-----|
| Access to services                                            | 49.04%    | 204 |
| Accessibility for persons with disabilities                   | 8.89%     | 37  |
| Addictions and mental health                                  | 16.83%    | 70  |
| Adequate and Affordable housing                               | 31.97%    | 133 |
| Community belonging                                           | 22.84%    | 95  |
| Community pride                                               | 20.19%    | 84  |
| Crime prevention                                              | 25.72%    | 107 |
| Discrimination                                                | 1.92%     | 8   |
| Domestic violence (male or female)                            | 10.10%    | 42  |
| Employment opportunities                                      | 44.23%    | 184 |
| Food security                                                 | 25.96%    | 108 |
| Healthy childhood development                                 | 18.27%    | 76  |
| Human trafficking                                             | 0.96%     | 4   |
| Mental health                                                 | 15.87%    | 66  |
| Personal and overall safety and security                      | 21.39%    | 89  |
| Physical activities,                                          | 21.15%    | 88  |
| Physical health, access to health care                        | 49.28%    | 205 |
| Poverty and income                                            | 12.98%    | 54  |
| Safe and well maintained walking areas with adequate lighting | 15.14%    | 63  |
| Skills development for employment                             | 9.86%     | 41  |
| Substance abuse and addiction                                 | 6.49%     | 27  |
| Support programs for seniors                                  | 27.88%    | 116 |
| Support programs for youth                                    | 14.66%    | 61  |
| Traffic safety on roads                                       | 20.43%    | 85  |
| Traffic safety on trails                                      | 4.09%     | 17  |
| Traffic safety on water                                       | 8.89%     | 37  |
| Transportation barriers                                       | 3.61%     | 15  |
| Victim Services, lack of                                      | 3.37%     | 14  |
| Youth Initiatives                                             | 14.66%    | 61  |
| Total Respondents: 416                                        |           |     |

### Q11 Overall my physical health is

Answered: 384 Skipped: 61

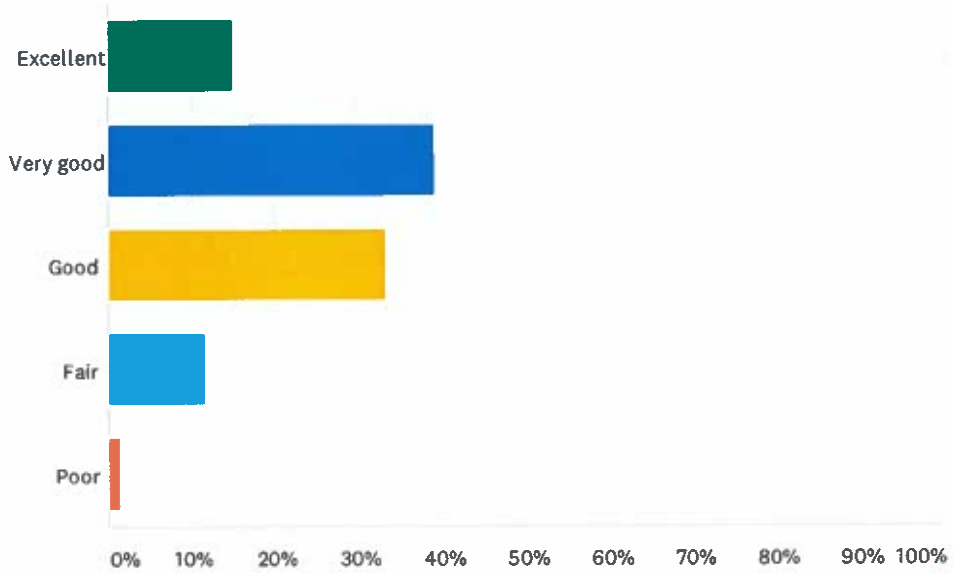

| ANSWER CHOICES | RESPONSES |            |
|----------------|-----------|------------|
| Excellent      | 14.84%    | 57         |
| Very good      | 39.06%    | 150        |
| Good           | 33.33%    | 128        |
| Fair           | 11.46%    | 44         |
| Poor           | 1.30%     | 5          |
| <b>TOTAL</b>   |           | <b>384</b> |

### Q12 I feel I can access adequate health care in my community, including supports for physical health and well being

Answered: 385 Skipped: 60

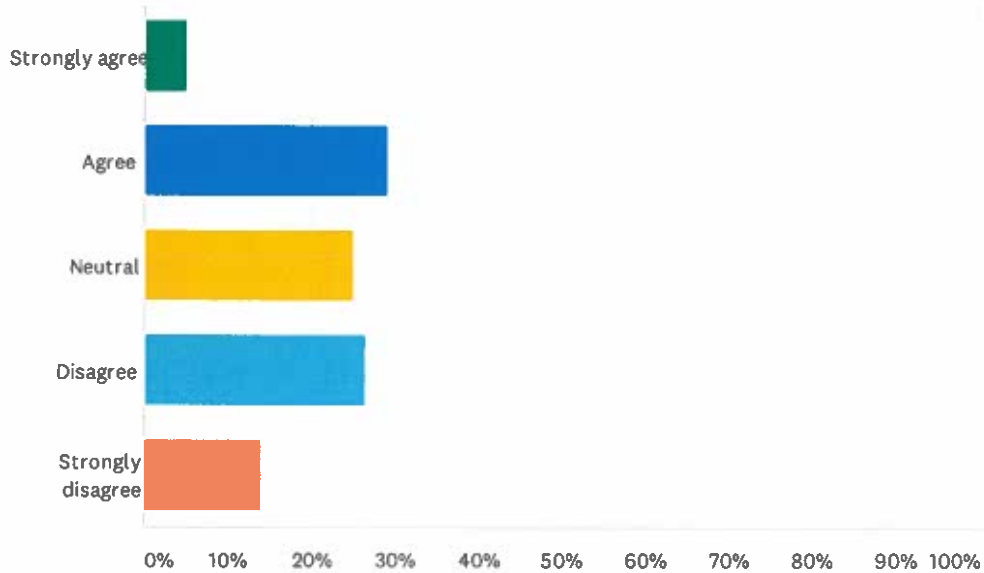

| ANSWER CHOICES    | RESPONSES |            |
|-------------------|-----------|------------|
| Strongly agree    | 4.94%     | 19         |
| Agree             | 29.35%    | 113        |
| Neutral           | 25.19%    | 97         |
| Disagree          | 26.49%    | 102        |
| Strongly disagree | 14.03%    | 54         |
| <b>TOTAL</b>      |           | <b>385</b> |

**Q13 Any supports or services you wish you had access to:**

Answered: 218 Skipped: 227

Almaguin Community Safety and Well Being Plan Survey 2020

| #  | RESPONSES                                                                                                                                                                                                                                                                                                                                                                          | DATE               |
|----|------------------------------------------------------------------------------------------------------------------------------------------------------------------------------------------------------------------------------------------------------------------------------------------------------------------------------------------------------------------------------------|--------------------|
| 1  | High speed internet                                                                                                                                                                                                                                                                                                                                                                | 6/7/2020 1:51 PM   |
| 2  | No                                                                                                                                                                                                                                                                                                                                                                                 | 6/6/2020 5:26 PM   |
| 3  | None that I can think of                                                                                                                                                                                                                                                                                                                                                           | 6/6/2020 10:24 AM  |
| 4  | there are no local doctors or walk in clinics                                                                                                                                                                                                                                                                                                                                      | 6/5/2020 4:59 PM   |
| 5  | Walk in clinic hours                                                                                                                                                                                                                                                                                                                                                               | 6/5/2020 3:28 PM   |
| 6  | No                                                                                                                                                                                                                                                                                                                                                                                 | 6/3/2020 3:53 PM   |
| 7  | Walk in clinic or better virtual internet access to health care.                                                                                                                                                                                                                                                                                                                   | 6/3/2020 2:01 PM   |
| 8  | Access to childcare for disabled parents                                                                                                                                                                                                                                                                                                                                           | 6/3/2020 1:02 AM   |
| 9  | Closer emergency services                                                                                                                                                                                                                                                                                                                                                          | 5/31/2020 10:58 PM |
| 10 | emergency health care                                                                                                                                                                                                                                                                                                                                                              | 5/29/2020 5:41 PM  |
| 11 | CPR / AED program due to long EMS response times; increased hospital ER capacity; access to helpful Telehealth in emergencies (Ontario just tells you to go to hospital after asking ten minutes of questions); better hiking / gym programs; bike paths.                                                                                                                          | 5/29/2020 9:02 AM  |
| 12 | local nursing station                                                                                                                                                                                                                                                                                                                                                              | 5/28/2020 8:29 PM  |
| 13 | We lack family doctors and nurse practitioners.                                                                                                                                                                                                                                                                                                                                    | 5/28/2020 12:46 PM |
| 14 | Fitness centre                                                                                                                                                                                                                                                                                                                                                                     | 5/28/2020 11:13 AM |
| 15 | Doctor nurse practitioner med lab                                                                                                                                                                                                                                                                                                                                                  | 5/28/2020 9:07 AM  |
| 16 | A doctor                                                                                                                                                                                                                                                                                                                                                                           | 5/27/2020 10:35 PM |
| 17 | A family dr!! Please hire a replacement for Dr Z.                                                                                                                                                                                                                                                                                                                                  | 5/27/2020 9:02 PM  |
| 18 | Family doctor which we pay tax's for but are not getting!!!!!!!!!!!!                                                                                                                                                                                                                                                                                                               | 5/27/2020 8:38 PM  |
| 19 | Family doctor                                                                                                                                                                                                                                                                                                                                                                      | 5/27/2020 6:41 PM  |
| 20 | Doctor, Speech pathologist ,                                                                                                                                                                                                                                                                                                                                                       | 5/27/2020 6:27 PM  |
| 21 | Better senior housing!                                                                                                                                                                                                                                                                                                                                                             | 5/27/2020 6:25 PM  |
| 22 | Doctor/ hospital                                                                                                                                                                                                                                                                                                                                                                   | 5/27/2020 6:08 PM  |
| 23 | A doctor would be good start                                                                                                                                                                                                                                                                                                                                                       | 5/27/2020 4:29 PM  |
| 24 | mental health care                                                                                                                                                                                                                                                                                                                                                                 | 5/26/2020 5:34 PM  |
| 25 | A doctor                                                                                                                                                                                                                                                                                                                                                                           | 5/26/2020 4:59 PM  |
| 26 | Should have more Doctors                                                                                                                                                                                                                                                                                                                                                           | 5/26/2020 4:55 PM  |
| 27 | As a seasonal resident (July to Oct) paying very high taxes, I would like access to the clinic in South River. Now I have to go to emerg at either NB or Huntsville for something that doesn't require emerg but those are my only options. Should be a walk in clinic or something that provides health services to seasonal residents--even a Nurse Practitioner would be great! | 5/26/2020 4:02 PM  |
| 28 | Medical clinic nearby                                                                                                                                                                                                                                                                                                                                                              | 5/26/2020 3:10 PM  |
| 29 | An indoor gym with classes                                                                                                                                                                                                                                                                                                                                                         | 5/26/2020 2:14 PM  |
| 30 | Sundridge needs another Family Doctor "IMMEDIATELY". I feel that there is not enough being done to attract a doctor. It has been almost one year since one was available permanently. Please get on this before people start dying!                                                                                                                                                | 5/26/2020 2:12 PM  |
| 31 | doctor, nurse, blood services                                                                                                                                                                                                                                                                                                                                                      | 5/26/2020 12:59 PM |
| 32 | Walk in doctors, doctors offices                                                                                                                                                                                                                                                                                                                                                   | 5/26/2020 11:51 AM |
| 33 | Counselling services. Lab access                                                                                                                                                                                                                                                                                                                                                   | 5/26/2020 11:17 AM |

## Almaguin Community Safety and Well Being Plan Survey 2020

|    |                                                                                                                                                                 |                    |
|----|-----------------------------------------------------------------------------------------------------------------------------------------------------------------|--------------------|
| 34 | Family Doctor or Nurse Practitioner led clinic                                                                                                                  | 5/26/2020 11:15 AM |
| 35 | More health care places and doctors                                                                                                                             | 5/26/2020 10:07 AM |
| 36 | More doctors. More mental health workers                                                                                                                        | 5/26/2020 10:01 AM |
| 37 | Walk in clinic                                                                                                                                                  | 5/26/2020 9:43 AM  |
| 38 | Better family doctor that listens to problems/concerns instead of making sure you have 8-12 months supply of medications!                                       | 5/26/2020 8:48 AM  |
| 39 | Doctor, dentist, nurse practitioner                                                                                                                             | 5/26/2020 7:37 AM  |
| 40 | I go to Huntsville to access a doctor, chiropractor.                                                                                                            | 5/26/2020 7:29 AM  |
| 41 | I would like to see community based health programming offering health and fitness classes for all ages                                                         | 5/26/2020 7:15 AM  |
| 42 | No                                                                                                                                                              | 5/25/2020 11:51 PM |
| 43 | Larger pharmacy & walk in clinic all year round                                                                                                                 | 5/25/2020 10:51 PM |
| 44 | no                                                                                                                                                              | 5/25/2020 10:30 PM |
| 45 | Physician                                                                                                                                                       | 5/25/2020 10:15 PM |
| 46 | More available health care. More public transportation                                                                                                          | 5/25/2020 8:20 PM  |
| 47 | Dentist, More Doctors, hearing Tests.                                                                                                                           | 5/25/2020 7:51 PM  |
| 48 | Physiotherapy, occupational therapy, chiropody, naturopathy, search & rescue, walk in clinic, community fitness/exercise programs, transportation services      | 5/25/2020 7:17 PM  |
| 49 | A permanent local doctor                                                                                                                                        | 5/25/2020 7:12 PM  |
| 50 | muskoka travel services —pick up from south river guided walking group ..trails                                                                                 | 5/25/2020 5:02 PM  |
| 51 | Physical therapy                                                                                                                                                | 5/25/2020 4:51 PM  |
| 52 | More extensive health resources without going out of town                                                                                                       | 5/25/2020 12:14 PM |
| 53 | gym                                                                                                                                                             | 5/25/2020 11:15 AM |
| 54 | Physiotherapist, dietitian, dentist, optometrist                                                                                                                | 5/25/2020 10:54 AM |
| 55 | Pool                                                                                                                                                            | 5/25/2020 10:36 AM |
| 56 | Doctor, dentist. even a Nurse Practitioner. ZERO healthcare.                                                                                                    | 5/25/2020 10:15 AM |
| 57 | More mental health and addiction services are needed.                                                                                                           | 5/25/2020 10:00 AM |
| 58 | therapists, specialists                                                                                                                                         | 5/25/2020 9:58 AM  |
| 59 | A family physician.                                                                                                                                             | 5/25/2020 8:48 AM  |
| 60 | A doctor! Or at least let us access the nurse practitioner! This is ridiculous seniors with no doctor.                                                          | 5/21/2020 1:53 PM  |
| 61 | More special services at the local Hospital. I hate having to drive to Toronto, Barrie, or Orillia for a ten minute consult Perhaps more telehealth would help. | 5/20/2020 11:12 AM |
| 62 | Closer to specialist doctors                                                                                                                                    | 5/19/2020 4:45 PM  |
| 63 | More access to medical specialists                                                                                                                              | 5/19/2020 4:03 PM  |
| 64 | doctor                                                                                                                                                          | 5/19/2020 12:21 PM |
| 65 | Walk-in clinic                                                                                                                                                  | 5/19/2020 10:58 AM |
| 66 | Mental Health                                                                                                                                                   | 5/19/2020 7:43 AM  |
| 67 | No                                                                                                                                                              | 5/18/2020 11:47 PM |
| 68 | Family physician                                                                                                                                                | 5/18/2020 9:19 PM  |

## Almaguin Community Safety and Well Being Plan Survey 2020

|    |                                                                                                                                                                                                                                                                                                                                                                                                                                                                                                                                          |                    |
|----|------------------------------------------------------------------------------------------------------------------------------------------------------------------------------------------------------------------------------------------------------------------------------------------------------------------------------------------------------------------------------------------------------------------------------------------------------------------------------------------------------------------------------------------|--------------------|
| 69 | I feel I have adequate access to most necessary health services                                                                                                                                                                                                                                                                                                                                                                                                                                                                          | 5/18/2020 7:28 PM  |
| 70 | No                                                                                                                                                                                                                                                                                                                                                                                                                                                                                                                                       | 5/18/2020 10:29 AM |
| 71 | Walk in health clinic                                                                                                                                                                                                                                                                                                                                                                                                                                                                                                                    | 5/17/2020 7:20 PM  |
| 72 | Internet services for home residence is needed.                                                                                                                                                                                                                                                                                                                                                                                                                                                                                          | 5/17/2020 4:01 PM  |
| 73 | live close to Huntsville with access to services there                                                                                                                                                                                                                                                                                                                                                                                                                                                                                   | 5/17/2020 3:13 PM  |
| 74 | Doctors appointment within 2 weeks instead of 2 months                                                                                                                                                                                                                                                                                                                                                                                                                                                                                   | 5/17/2020 2:07 PM  |
| 75 | Family dr                                                                                                                                                                                                                                                                                                                                                                                                                                                                                                                                | 5/16/2020 11:48 PM |
| 76 | Not at present                                                                                                                                                                                                                                                                                                                                                                                                                                                                                                                           | 5/16/2020 6:53 PM  |
| 77 | This area needs ologists, gynecologists, cardiologists, etc. etc. etc. There are none in Huntsville.                                                                                                                                                                                                                                                                                                                                                                                                                                     | 5/16/2020 5:32 PM  |
| 78 | MRI, specialists, sleep apnea clinic                                                                                                                                                                                                                                                                                                                                                                                                                                                                                                     | 5/16/2020 5:21 PM  |
| 79 | A doctor closer than North Bay.                                                                                                                                                                                                                                                                                                                                                                                                                                                                                                          | 5/16/2020 12:35 PM |
| 80 | Doctor, Nurse Practitioner                                                                                                                                                                                                                                                                                                                                                                                                                                                                                                               | 5/16/2020 12:23 PM |
| 81 | Indoor pool                                                                                                                                                                                                                                                                                                                                                                                                                                                                                                                              | 5/16/2020 9:21 AM  |
| 82 | Walk in Clinic, better roads, dump open all week (again) but we have a great fire department!                                                                                                                                                                                                                                                                                                                                                                                                                                            | 5/16/2020 8:38 AM  |
| 83 | A family physician, presently without one at all                                                                                                                                                                                                                                                                                                                                                                                                                                                                                         | 5/16/2020 6:17 AM  |
| 84 | Family doctor                                                                                                                                                                                                                                                                                                                                                                                                                                                                                                                            | 5/15/2020 11:18 PM |
| 85 | Hospital funding needs to recognize the entire population of the area not just permanent residents. The so-called 'seasonal' residents are maybe better described as 'intermittent' as many use their properties year round as well as for extended periods. This will only increase moving forward as current building standards require most new dwellings to be constructed as four season. There is no 'off season' any longer.                                                                                                      | 5/15/2020 6:46 PM  |
| 86 | Waiting for a replacement for Doctor. Wish my family had access to Nurse Practitioner.                                                                                                                                                                                                                                                                                                                                                                                                                                                   | 5/15/2020 1:05 PM  |
| 87 | CHiropractic                                                                                                                                                                                                                                                                                                                                                                                                                                                                                                                             | 5/15/2020 12:12 PM |
| 88 | Family Doctor, Walk in Clinic                                                                                                                                                                                                                                                                                                                                                                                                                                                                                                            | 5/15/2020 10:33 AM |
| 89 | eventually people in this municipality will have to leave as the taxes that support services are unsustainable. So no more services,                                                                                                                                                                                                                                                                                                                                                                                                     | 5/15/2020 8:12 AM  |
| 90 | Physio therapy Many in the area do not have a family physician Programs for health, nutrition, physical fitness Need mental health support in our area.                                                                                                                                                                                                                                                                                                                                                                                  | 5/15/2020 1:32 AM  |
| 91 | I have a family doctor but my husband and stepsons do not. This is a priority to address! The lack of urgent care is also a problem... Huntsville and North Bay don't have much either.                                                                                                                                                                                                                                                                                                                                                  | 5/14/2020 10:56 PM |
| 92 | A replacement for Dr. Zei dler is Obvious. With the aged population, disabled persons as well those caring for aged people are left out and seems nobody cares. There is no good reason why he has yet to be replaced and makes me wonder why he really left. When 8 moved my senior parents here he took them in . In a few short months later without enough notice he was gone and here we are, with nothing!! It is unbelievable to me this is acceptable. Community members are not happy!! Health care is a priority, make it one! | 5/14/2020 8:00 PM  |
| 93 | A family physician. I don't have a doctor nor does my husband. It's been almost 2 years and no doctor.                                                                                                                                                                                                                                                                                                                                                                                                                                   | 5/14/2020 6:52 PM  |
| 94 | Physiotherapy More Dr and nurse practitioners                                                                                                                                                                                                                                                                                                                                                                                                                                                                                            | 5/14/2020 12:02 PM |
| 95 | A family Doctor                                                                                                                                                                                                                                                                                                                                                                                                                                                                                                                          | 5/14/2020 12:02 PM |
| 96 | Nothing comes to mind                                                                                                                                                                                                                                                                                                                                                                                                                                                                                                                    | 5/14/2020 11:22 AM |
| 97 | Doctor, dentist, nurse practitioner; somebody with integrity.                                                                                                                                                                                                                                                                                                                                                                                                                                                                            | 5/14/2020 11:18 AM |
| 98 | I wish there were more access to doctors, nurse practitioners and community health mental                                                                                                                                                                                                                                                                                                                                                                                                                                                | 5/14/2020 9:09 AM  |

## Almaguin Community Safety and Well Being Plan Survey 2020

### health services

|     |                                                                                                                                                                                                                                                                                                                                                                                    |                    |
|-----|------------------------------------------------------------------------------------------------------------------------------------------------------------------------------------------------------------------------------------------------------------------------------------------------------------------------------------------------------------------------------------|--------------------|
| 99  | a full community center with activities                                                                                                                                                                                                                                                                                                                                            | 5/14/2020 9:03 AM  |
| 100 | Family Doctor                                                                                                                                                                                                                                                                                                                                                                      | 5/14/2020 7:44 AM  |
| 101 | Family Doctor would be nice                                                                                                                                                                                                                                                                                                                                                        | 5/14/2020 7:33 AM  |
| 102 | Medical clinic in magnetawan with a NP , that has a lab                                                                                                                                                                                                                                                                                                                            | 5/14/2020 7:24 AM  |
| 103 | General Practitioner Laboratory                                                                                                                                                                                                                                                                                                                                                    | 5/14/2020 1:03 AM  |
| 104 | Mental health supports - without being on a long wait list or having to travel far. Access to gym/training to be more physically healthy.                                                                                                                                                                                                                                          | 5/13/2020 10:22 PM |
| 105 | N/a                                                                                                                                                                                                                                                                                                                                                                                | 5/13/2020 9:51 PM  |
| 106 | Mental health                                                                                                                                                                                                                                                                                                                                                                      | 5/13/2020 9:03 PM  |
| 107 | Larger pharmacy                                                                                                                                                                                                                                                                                                                                                                    | 5/13/2020 8:45 PM  |
| 108 | Doctor                                                                                                                                                                                                                                                                                                                                                                             | 5/13/2020 8:38 PM  |
| 109 | General Practitioner                                                                                                                                                                                                                                                                                                                                                               | 5/13/2020 8:32 PM  |
| 110 | Urgent Care Clinic                                                                                                                                                                                                                                                                                                                                                                 | 5/13/2020 7:58 PM  |
| 111 | Swimming pool                                                                                                                                                                                                                                                                                                                                                                      | 5/13/2020 7:47 PM  |
| 112 | A community centre that was a hub with a playground and things for youth to do like a skate park, climbing wall, indoor pool with hot tub to enjoy during the winter time, banquet facilities to rent out, park like setting with outdoor campfire grills for daytime use, community gardens, multi-use trails, with a family restaurant, near the Sundridge arena would be great. | 5/13/2020 7:32 PM  |
| 113 | I have always gone to Huntsville, but still have my dentist in Toronto where I lived previously.                                                                                                                                                                                                                                                                                   | 5/13/2020 7:21 PM  |
| 114 | After hours clinics. More physicians.                                                                                                                                                                                                                                                                                                                                              | 5/13/2020 7:14 PM  |
| 115 | activity groups/clubs/events                                                                                                                                                                                                                                                                                                                                                       | 5/13/2020 6:42 PM  |
| 116 | A family Dr                                                                                                                                                                                                                                                                                                                                                                        | 5/13/2020 6:41 PM  |
| 117 | Mental health                                                                                                                                                                                                                                                                                                                                                                      | 5/13/2020 6:41 PM  |
| 118 | Family doctor, more physical activity/recreation programs for children/families year round                                                                                                                                                                                                                                                                                         | 5/13/2020 6:39 PM  |
| 119 | Better PSW accessibility. Chiropody service, physiotherapy. Therapy pool                                                                                                                                                                                                                                                                                                           | 5/13/2020 6:20 PM  |
| 120 | Better internet services                                                                                                                                                                                                                                                                                                                                                           | 5/13/2020 5:45 PM  |
| 121 | Doctor Walking and Bike Trails                                                                                                                                                                                                                                                                                                                                                     | 5/13/2020 5:37 PM  |
| 122 | there needs to a walk in clinic in the area                                                                                                                                                                                                                                                                                                                                        | 5/13/2020 4:13 PM  |
| 123 | Doctor or rpn                                                                                                                                                                                                                                                                                                                                                                      | 5/13/2020 4:04 PM  |
| 124 | Doctor, dentist, walk-in clinic                                                                                                                                                                                                                                                                                                                                                    | 5/13/2020 4:01 PM  |
| 125 | community centre with pool and indoor walking/running track                                                                                                                                                                                                                                                                                                                        | 5/13/2020 3:49 PM  |
| 126 | Community based indoor recreation facility                                                                                                                                                                                                                                                                                                                                         | 5/13/2020 1:40 PM  |
| 127 | Pools, gyms, kids stuff                                                                                                                                                                                                                                                                                                                                                            | 5/13/2020 12:42 PM |
| 128 | More services geared to physical therapy and rehabilitation for individuals with long term injuries.                                                                                                                                                                                                                                                                               | 5/13/2020 12:08 PM |
| 129 | Xray, more doctors, Hospitals, home care for seniors,                                                                                                                                                                                                                                                                                                                              | 5/13/2020 11:42 AM |
| 130 | Recreational centre with pool and gym or board walk/walking trails                                                                                                                                                                                                                                                                                                                 | 5/13/2020 11:40 AM |
| 131 | A family physician or ability to access NP without a physician. Would be thrilled to have NP led clinic like many other locations have. We have excellent mental health support in the community for children.                                                                                                                                                                     | 5/13/2020 11:35 AM |



## Almaguin Community Safety and Well Being Plan Survey 2020

|     |                                                                                                                                                                                                                                                                                                                                                                                                         |                    |
|-----|---------------------------------------------------------------------------------------------------------------------------------------------------------------------------------------------------------------------------------------------------------------------------------------------------------------------------------------------------------------------------------------------------------|--------------------|
| 132 | A doctor would good, we have one doctor and nurse practitioner and can't use either, does that sound like good health care to you!                                                                                                                                                                                                                                                                      | 5/13/2020 10:37 AM |
| 133 | Family physician or Nurse Practitioner                                                                                                                                                                                                                                                                                                                                                                  | 5/13/2020 10:19 AM |
| 134 | easier access to doctor and nurse practitioner. Hours are not easy for working families. Need of a community hub with adult and student sports, arts.                                                                                                                                                                                                                                                   | 5/13/2020 10:16 AM |
| 135 | More mental                                                                                                                                                                                                                                                                                                                                                                                             | 5/13/2020 10:11 AM |
| 136 | A doctor                                                                                                                                                                                                                                                                                                                                                                                                | 5/13/2020 9:56 AM  |
| 137 | Doctor                                                                                                                                                                                                                                                                                                                                                                                                  | 5/13/2020 9:50 AM  |
| 138 | Sundridge needs a Family PHYSICIAN ASAP!!!!!!!!!!!!!!!                                                                                                                                                                                                                                                                                                                                                  | 5/13/2020 9:33 AM  |
| 139 | A walk-in clinic is needed.                                                                                                                                                                                                                                                                                                                                                                             | 5/13/2020 9:32 AM  |
| 140 | More sport activities for seniors to promote physical activity                                                                                                                                                                                                                                                                                                                                          | 5/13/2020 9:32 AM  |
| 141 | better access to Doctors in this area                                                                                                                                                                                                                                                                                                                                                                   | 5/13/2020 9:20 AM  |
| 142 | A doctor and/or a nurse practitioner who can see patients who do not have a doctor                                                                                                                                                                                                                                                                                                                      | 5/13/2020 9:00 AM  |
| 143 | Walk in medical                                                                                                                                                                                                                                                                                                                                                                                         | 5/13/2020 8:25 AM  |
| 144 | Medical care of any kind. Over a year now on the waiting list for a doctor.                                                                                                                                                                                                                                                                                                                             | 5/13/2020 7:03 AM  |
| 145 | Doctors                                                                                                                                                                                                                                                                                                                                                                                                 | 5/13/2020 6:01 AM  |
| 146 | Grants for seniors that are really accesible, and are true not just governement propaganda.                                                                                                                                                                                                                                                                                                             | 5/12/2020 11:24 PM |
| 147 | Walk in clinics                                                                                                                                                                                                                                                                                                                                                                                         | 5/12/2020 10:42 PM |
| 148 | easier access to a doctor                                                                                                                                                                                                                                                                                                                                                                               | 5/12/2020 9:57 PM  |
| 149 | Family Doctor - Local                                                                                                                                                                                                                                                                                                                                                                                   | 5/12/2020 9:29 PM  |
| 150 | access to skilled doctors, health care Nurse practionaires are impossible to access                                                                                                                                                                                                                                                                                                                     | 5/12/2020 9:25 PM  |
| 151 | Dental care.                                                                                                                                                                                                                                                                                                                                                                                            | 5/12/2020 8:38 PM  |
| 152 | Wish health center had cray dept.                                                                                                                                                                                                                                                                                                                                                                       | 5/12/2020 6:26 PM  |
| 153 | Doctors                                                                                                                                                                                                                                                                                                                                                                                                 | 5/12/2020 5:19 PM  |
| 154 | Would love to see a walk in clinic reinstated. We are 30 mins away from a hospital. A walk in would also reduce the burden on local hospitals for minor ailments.                                                                                                                                                                                                                                       | 5/12/2020 3:27 PM  |
| 155 | Emergency medical care                                                                                                                                                                                                                                                                                                                                                                                  | 5/12/2020 2:29 PM  |
| 156 | n/a                                                                                                                                                                                                                                                                                                                                                                                                     | 5/12/2020 2:05 PM  |
| 157 | None                                                                                                                                                                                                                                                                                                                                                                                                    | 5/12/2020 2:01 PM  |
| 158 | local medical clinic/ nurse practitioner like we used to have at Burks Falls                                                                                                                                                                                                                                                                                                                            | 5/12/2020 1:37 PM  |
| 159 | Xarys at health centre in Burk's Falls                                                                                                                                                                                                                                                                                                                                                                  | 5/12/2020 1:19 PM  |
| 160 | Doctors or nurse practitioners. Emergency clinic. Huntsville is too far and not adequate.                                                                                                                                                                                                                                                                                                               | 5/12/2020 1:05 PM  |
| 161 | I don't personally need support at the present time but we live in a black hole when it comes to health care. -- ie no hospital, shortage of doctors, those who control Ontario's health system don't even know where we are and make no effort to find out. On attending a recent meeting on the new Ontario Health Teams, it became obvious that no contiguous part of the area wants any part of us. | 5/12/2020 12:47 PM |
| 162 | Doctor or nursing station, our was taken away a few years ago.                                                                                                                                                                                                                                                                                                                                          | 5/12/2020 12:42 PM |
| 163 | Family doctor.                                                                                                                                                                                                                                                                                                                                                                                          | 5/12/2020 12:39 PM |
| 164 | Doctor. Dentist. Alternative Medicine.                                                                                                                                                                                                                                                                                                                                                                  | 5/12/2020 11:33 AM |
| 165 | A doctor, a counsellor,                                                                                                                                                                                                                                                                                                                                                                                 | 5/12/2020 11:09 AM |

## Almaguin Community Safety and Well Being Plan Survey 2020

|     |                                                                                                                                                                                                                                                                                          |                    |
|-----|------------------------------------------------------------------------------------------------------------------------------------------------------------------------------------------------------------------------------------------------------------------------------------------|--------------------|
| 166 | AN URGENT CARE OR CLINIC AVAILABLE, TO FAR TO HOSPITALS IF URGENT CARE IS NEEDED                                                                                                                                                                                                         | 5/12/2020 10:36 AM |
| 167 | n/a                                                                                                                                                                                                                                                                                      | 5/12/2020 10:19 AM |
| 168 | IVF, urgent care                                                                                                                                                                                                                                                                         | 5/12/2020 9:42 AM  |
| 169 | I dont have a doctor yet. Still on waiting list                                                                                                                                                                                                                                          | 5/12/2020 9:01 AM  |
| 170 | the wait list for mental health are long and wait lists for doctors its hard for people to access services when they need it                                                                                                                                                             | 5/12/2020 8:58 AM  |
| 171 | family doctor, eye doctor, massage therapist, family therapy                                                                                                                                                                                                                             | 5/12/2020 8:53 AM  |
| 172 | No                                                                                                                                                                                                                                                                                       | 5/12/2020 6:20 AM  |
| 173 | a gym with equipment                                                                                                                                                                                                                                                                     | 5/11/2020 11:35 PM |
| 174 | a doctor in Almaguin.                                                                                                                                                                                                                                                                    | 5/11/2020 11:21 PM |
| 175 | Better access to and follow up with mental health services/councillors                                                                                                                                                                                                                   | 5/11/2020 11:04 PM |
| 176 | hi speed internet                                                                                                                                                                                                                                                                        | 5/11/2020 10:30 PM |
| 177 | Better access to health care and family doctors                                                                                                                                                                                                                                          | 5/11/2020 10:27 PM |
| 178 | Local health nurse Maybe once a week at the community centre or at the township office no blood pressure monitoring stuff like that                                                                                                                                                      | 5/11/2020 10:09 PM |
| 179 | More gym access at an affordable rate                                                                                                                                                                                                                                                    | 5/11/2020 9:47 PM  |
| 180 | Sidewalks and street lights to allow ability to walk safely in the community                                                                                                                                                                                                             | 5/11/2020 9:33 PM  |
| 181 | Health group activities including nutrition and physical activities                                                                                                                                                                                                                      | 5/11/2020 9:16 PM  |
| 182 | better mental health suport                                                                                                                                                                                                                                                              | 5/11/2020 9:09 PM  |
| 183 | I have a doctor but it takes several weeks waiting for an appointment.                                                                                                                                                                                                                   | 5/11/2020 8:55 PM  |
| 184 | Health care. Better mental health. Walk in clinic.                                                                                                                                                                                                                                       | 5/11/2020 8:38 PM  |
| 185 | Urgent care centre                                                                                                                                                                                                                                                                       | 5/11/2020 8:37 PM  |
| 186 | None                                                                                                                                                                                                                                                                                     | 5/11/2020 8:37 PM  |
| 187 | Walk in clinic                                                                                                                                                                                                                                                                           | 5/11/2020 8:24 PM  |
| 188 | Gym to workout                                                                                                                                                                                                                                                                           | 5/11/2020 7:54 PM  |
| 189 | Mental health being an x Perry firefighter                                                                                                                                                                                                                                               | 5/11/2020 7:05 PM  |
| 190 | A doctor                                                                                                                                                                                                                                                                                 | 5/11/2020 5:47 PM  |
| 191 | More physical activities for children and adults.                                                                                                                                                                                                                                        | 5/11/2020 5:30 PM  |
| 192 | family doctor for husband                                                                                                                                                                                                                                                                | 5/11/2020 5:20 PM  |
| 193 | doctor                                                                                                                                                                                                                                                                                   | 5/11/2020 5:12 PM  |
| 194 | A Hospital in Almaguin                                                                                                                                                                                                                                                                   | 5/11/2020 5:06 PM  |
| 195 | doctor, dog parks                                                                                                                                                                                                                                                                        | 5/11/2020 5:03 PM  |
| 196 | I dont know of any supports in my community.                                                                                                                                                                                                                                             | 5/11/2020 5:01 PM  |
| 197 | All medical supports are not available in Almaguin, we must go to Muskoka or Northbay or Parry Sound to get any medical support                                                                                                                                                          | 5/11/2020 5:01 PM  |
| 198 | Health care 7 days a week. It's so wrong that our Dr. Offices are only open a few days a week, and then having to go to Huntsville if something really is wrong. People who work have to take time off of work when we eventually have a doctors appointment. Longer hours or something. | 5/11/2020 4:59 PM  |
| 199 | Easier access to long term care, and home care support                                                                                                                                                                                                                                   | 5/11/2020 4:47 PM  |
| 200 | Would love to have a walk-in clinic available.                                                                                                                                                                                                                                           | 5/11/2020 4:37 PM  |

## Almaguin Community Safety and Well Being Plan Survey 2020

|     |                                                                                                                                                                                                                                                                                                                                                                                     |                   |
|-----|-------------------------------------------------------------------------------------------------------------------------------------------------------------------------------------------------------------------------------------------------------------------------------------------------------------------------------------------------------------------------------------|-------------------|
| 201 | Dental                                                                                                                                                                                                                                                                                                                                                                              | 5/11/2020 4:35 PM |
| 202 | more access to mental health counselling services especially during this pandemic.                                                                                                                                                                                                                                                                                                  | 5/11/2020 4:33 PM |
| 203 | Programs for toddler aged 2+ Food program with grocery stores and/or restaurants                                                                                                                                                                                                                                                                                                    | 5/11/2020 4:24 PM |
| 204 | Summer camp/activities for the kids                                                                                                                                                                                                                                                                                                                                                 | 5/11/2020 4:14 PM |
| 205 | dental, therapists, masseurs                                                                                                                                                                                                                                                                                                                                                        | 5/11/2020 4:13 PM |
| 206 | Walk-in clinic to avoid spending hours waiting in the huntsville hospital                                                                                                                                                                                                                                                                                                           | 5/11/2020 4:11 PM |
| 207 | Literally anything besides a lab                                                                                                                                                                                                                                                                                                                                                    | 5/11/2020 4:08 PM |
| 208 | Gym's, dentist, clothing stores                                                                                                                                                                                                                                                                                                                                                     | 5/11/2020 4:06 PM |
| 209 | Physio and counselling.                                                                                                                                                                                                                                                                                                                                                             | 5/11/2020 4:04 PM |
| 210 | I wish I had a doctor. I'm on a list and was told, me and 1,000 people then tje girl smiled at me.                                                                                                                                                                                                                                                                                  | 5/11/2020 4:03 PM |
| 211 | More mental health                                                                                                                                                                                                                                                                                                                                                                  | 5/11/2020 4:02 PM |
| 212 | Now that Provincial Parks are open to day use for walking trails, Burk's Falls should officially reopen the River Walk trails to public use to benefit physical and mental wellness and health. People should be encouraged to physical distance but the bulk of the research indicates that there is a very low risk of infection to Covid-19 in outdoor scenarios of this nature. | 5/11/2020 4:02 PM |
| 213 | More access to walk in clinics, gym facilities, walking paths, pharmacy services                                                                                                                                                                                                                                                                                                    | 5/11/2020 3:49 PM |
| 214 | Doctors, mental health services                                                                                                                                                                                                                                                                                                                                                     | 5/11/2020 3:45 PM |
| 215 | Closer to Hospital and Still waiting for selection of a personal physician                                                                                                                                                                                                                                                                                                          | 5/11/2020 3:45 PM |
| 216 | Doctors                                                                                                                                                                                                                                                                                                                                                                             | 5/11/2020 3:38 PM |
| 217 | Urgent care/ walk in clinic, nurse practioner, optometrist.                                                                                                                                                                                                                                                                                                                         | 5/11/2020 3:34 PM |
| 218 | gym                                                                                                                                                                                                                                                                                                                                                                                 | 5/11/2020 3:31 PM |

### Q14 Overall my mental health is

Answered: 383 Skipped: 62

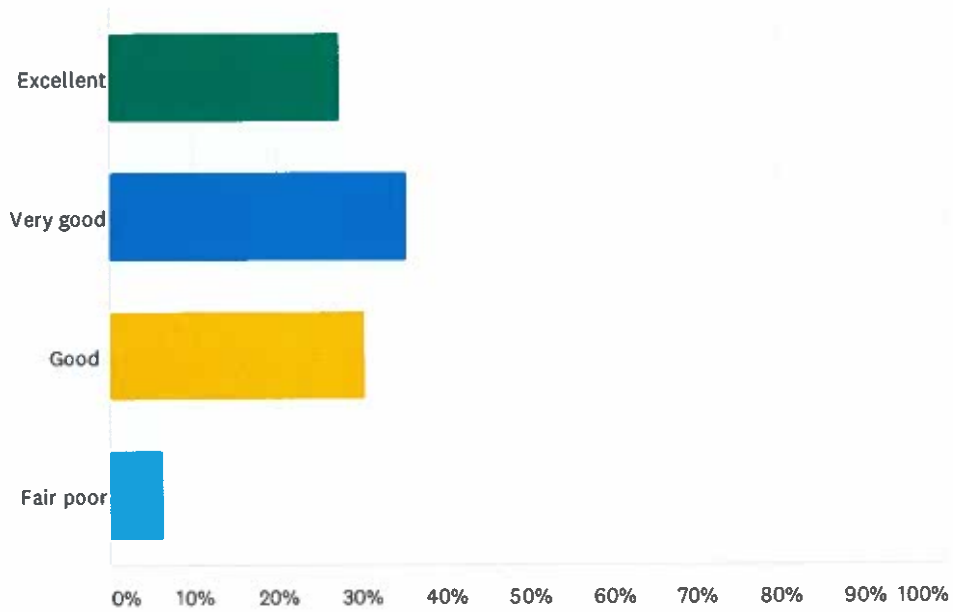

| ANSWER CHOICES | RESPONSES |            |
|----------------|-----------|------------|
| Excellent      | 27.68%    | 106        |
| Very good      | 35.51%    | 136        |
| Good           | 30.55%    | 117        |
| Fair poor      | 6.27%     | 24         |
| <b>TOTAL</b>   |           | <b>383</b> |

### Q15 Do you have access to healthcare benefits for physical or mental health supports?

Answered: 382 Skipped: 63

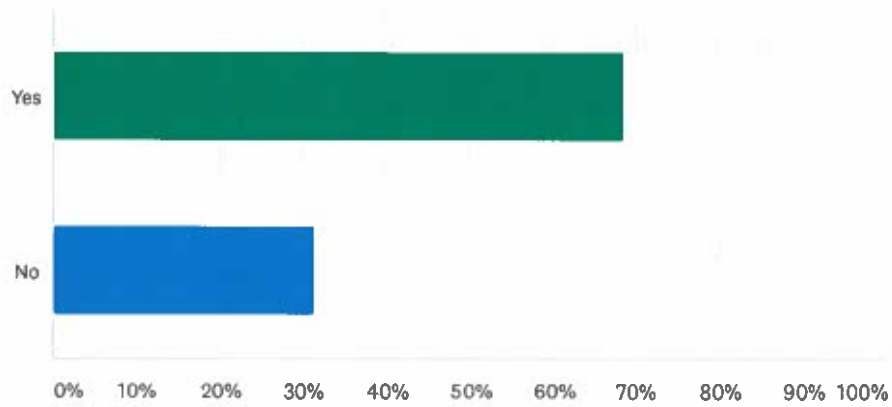

| ANSWER CHOICES | RESPONSES |     |
|----------------|-----------|-----|
| Yes            | 68.59%    | 262 |
| No             | 31.41%    | 120 |
| TOTAL          |           | 382 |

**Q16 In the past 12 months, have you experienced negative impacts (emotional, physical, financial tec.) due to any of the following:**

Answered: 384 Skipped: 61

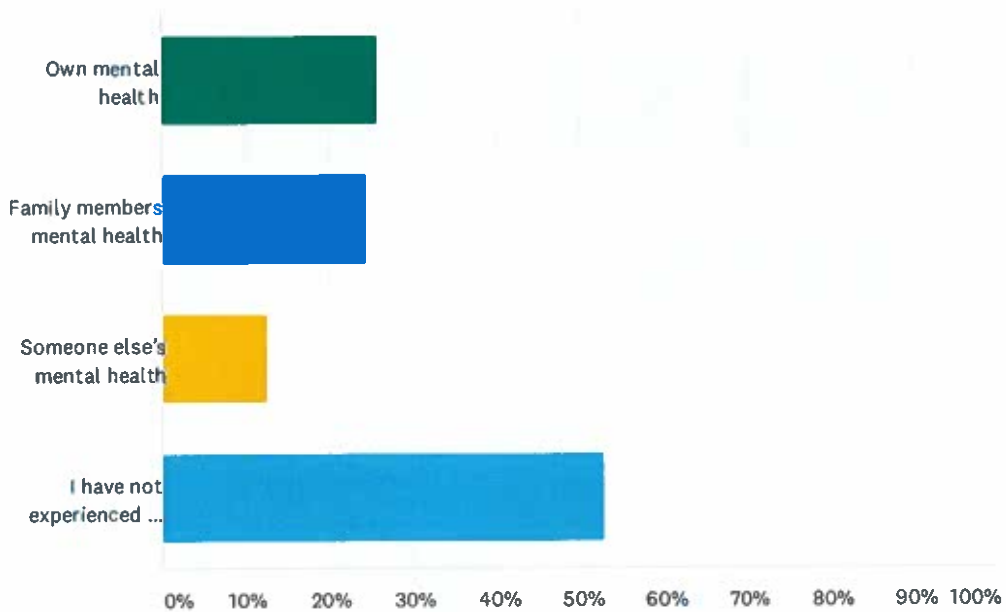

| ANSWER CHOICES                              | RESPONSES |     |
|---------------------------------------------|-----------|-----|
| Own mental health                           | 26.04%    | 100 |
| Family members mental health                | 24.48%    | 94  |
| Someone else's mental health                | 12.50%    | 48  |
| I have not experienced any negative impacts | 52.86%    | 203 |
| Total Respondents: 384                      |           |     |

### Q17 The following factors have impacted my ability to receive proper physical or mental health supports:

Answered: 377 Skipped: 68

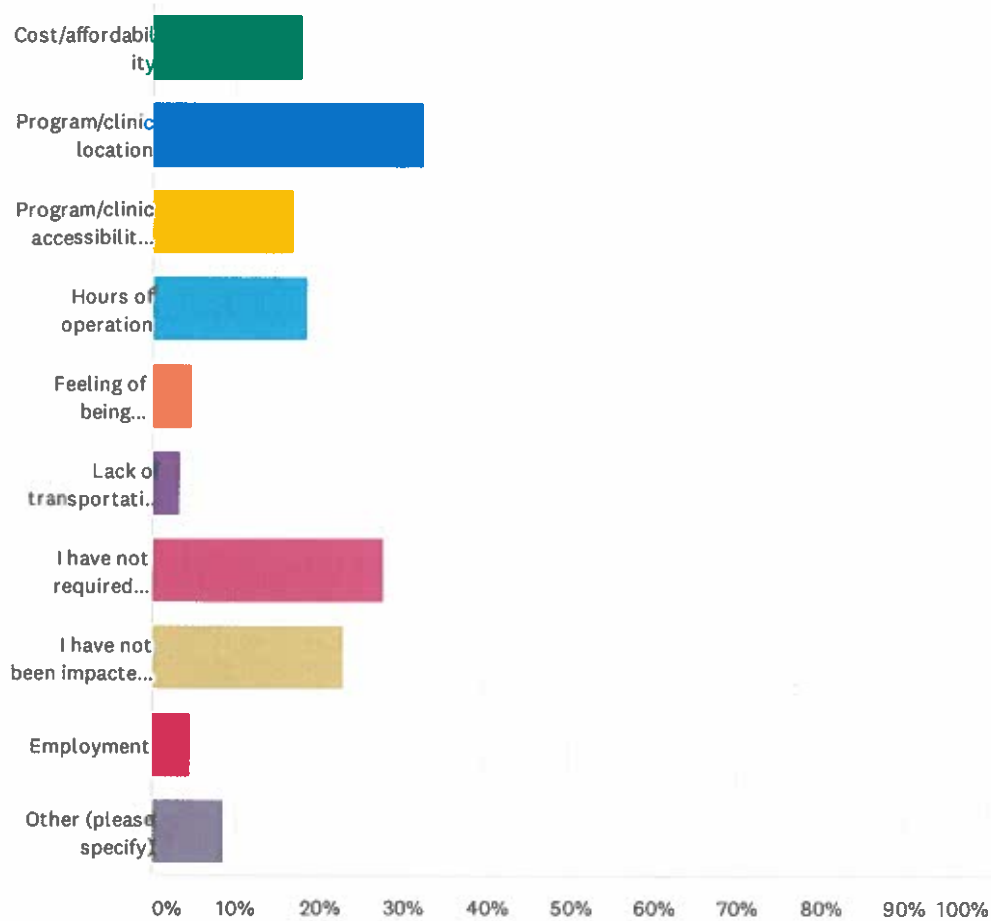

Almaguin Community Safety and Well Being Plan Survey 2020

| ANSWER CHOICES                                 | RESPONSES |     |
|------------------------------------------------|-----------|-----|
| Cost/affordability                             | 18.04%    | 68  |
| Program/clinic location                        | 32.63%    | 123 |
| Program/clinic accessibility                   | 16.98%    | 64  |
| Hours of operation                             | 18.57%    | 70  |
| Feeling of being unwelcome/judged in a program | 4.77%     | 18  |
| Lack of transportation to program              | 3.45%     | 13  |
| I have not required supports                   | 27.85%    | 105 |
| I have not been impacted by these factors      | 23.08%    | 87  |
| Employment                                     | 4.51%     | 17  |
| Other (please specify)                         | 8.49%     | 32  |
| Total Respondents: 377                         |           |     |



## Almaguin Community Safety and Well Being Plan Survey 2020

| #  | OTHER (PLEASE SPECIFY)                                                                                                                                                                                                                      | DATE               |
|----|---------------------------------------------------------------------------------------------------------------------------------------------------------------------------------------------------------------------------------------------|--------------------|
| 1  | Luckily I have a doctor in Huntsville however, my parents do not have a doctor.                                                                                                                                                             | 5/28/2020 12:46 PM |
| 2  | lack of doctor                                                                                                                                                                                                                              | 5/27/2020 4:29 PM  |
| 3  | I have been able to receive and afford care required from Port Hope, Ontario my primary residence                                                                                                                                           | 5/26/2020 4:02 PM  |
| 4  | Need a permanent Doctor to care for the other half of the population of Sundridge. We have the haves and the have nots here! Can not even access the Nurse Practitioner for health care!                                                    | 5/26/2020 2:12 PM  |
| 5  | I am on a waiting list with Healthcare connect. Still waiting to find health care provider within 100KM                                                                                                                                     | 5/26/2020 7:37 AM  |
| 6  | None                                                                                                                                                                                                                                        | 5/25/2020 11:51 PM |
| 7  | Pandemic                                                                                                                                                                                                                                    | 5/25/2020 6:53 PM  |
| 8  | None of these apply as of now but could very well happen down the road so I have marked those.                                                                                                                                              | 5/25/2020 12:14 PM |
| 9  | There are no doctors available. Healthcare Connect has been working on it for THREE YEARS.                                                                                                                                                  | 5/25/2020 10:15 AM |
| 10 | There is No doctor to go to. No one to refer us to specialists or mental or physical specialists. My dentist cancelled my appointment because my blood pressure was high and I do not have a doctor. So now I dont have dental care either! | 5/21/2020 1:53 PM  |
| 11 | Shortage of physicians - not taking new patients.                                                                                                                                                                                           | 5/18/2020 9:19 PM  |
| 12 | no personal need                                                                                                                                                                                                                            | 5/16/2020 2:52 PM  |
| 13 | Cannot roster and no close by emergency department                                                                                                                                                                                          | 5/16/2020 8:38 AM  |
| 14 | No available, local family physician                                                                                                                                                                                                        | 5/16/2020 6:17 AM  |
| 15 | Covid19 nurses or doctors can't see us in person                                                                                                                                                                                            | 5/15/2020 1:05 PM  |
| 16 | Have to travel to Huntsville for Physiotherapist                                                                                                                                                                                            | 5/15/2020 1:32 AM  |
| 17 | My husband and I do not have a doctor.                                                                                                                                                                                                      | 5/14/2020 6:52 PM  |
| 18 | We're very busy so it's quite difficult to schedule appointments                                                                                                                                                                            | 5/14/2020 11:22 AM |
| 19 | Quality of life                                                                                                                                                                                                                             | 5/13/2020 5:45 PM  |
| 20 | Unaware of what is available in my community                                                                                                                                                                                                | 5/13/2020 4:55 PM  |
| 21 | We don't have a doctor                                                                                                                                                                                                                      | 5/13/2020 11:35 AM |
| 22 | lack of doctor                                                                                                                                                                                                                              | 5/13/2020 10:37 AM |
| 23 | Have NO doctor period! I am 69-years-old and in need of a local doctor.                                                                                                                                                                     | 5/13/2020 9:33 AM  |
| 24 | No sports available for seniors                                                                                                                                                                                                             | 5/13/2020 9:32 AM  |
| 25 | Local mental health support is not available locally.                                                                                                                                                                                       | 5/12/2020 1:55 PM  |
| 26 | My current health needs are covered locally or by travelling to a specialist in Sudbury.                                                                                                                                                    | 5/12/2020 12:47 PM |
| 27 | No clinic                                                                                                                                                                                                                                   | 5/12/2020 12:42 PM |
| 28 | Being too busy                                                                                                                                                                                                                              | 5/12/2020 9:42 AM  |
| 29 | Was dropped without explanation from program/no follow up                                                                                                                                                                                   | 5/11/2020 11:04 PM |
| 30 | there is a large waiting time for mental health                                                                                                                                                                                             | 5/11/2020 9:09 PM  |
| 31 | There is a long wait time to get into Counselling services                                                                                                                                                                                  | 5/11/2020 4:33 PM  |
| 32 | The lack of promptly being referred to specialists                                                                                                                                                                                          | 5/11/2020 4:06 PM  |

**Q18 In the past 12 months did drinking alcohol negatively impact any of the following (select all that apply):**

Answered: 352 Skipped: 93

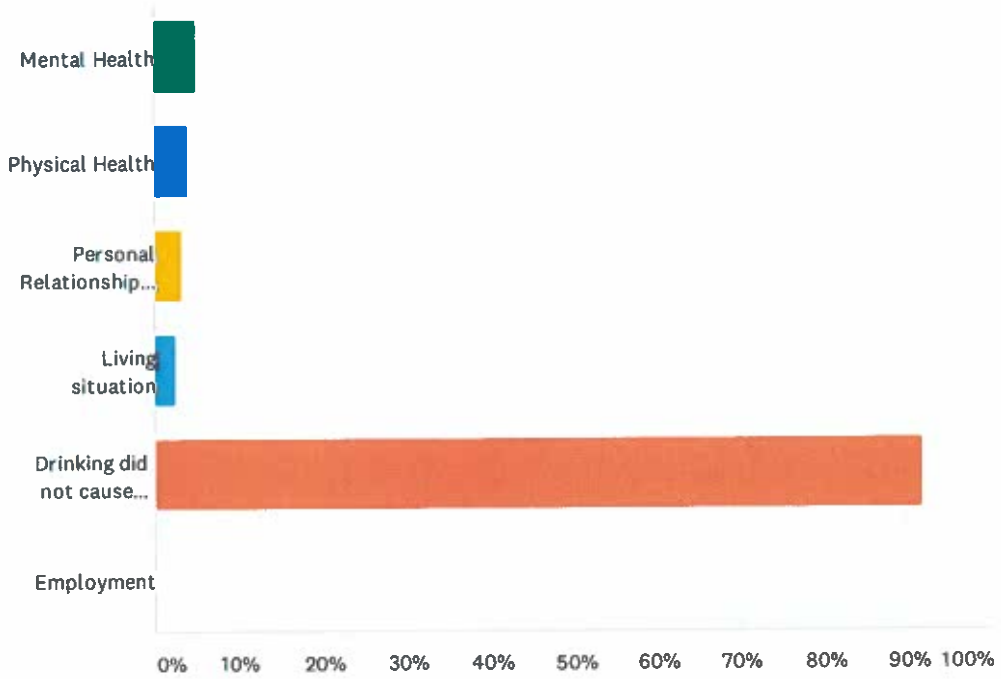

| ANSWER CHOICES                           | RESPONSES |     |
|------------------------------------------|-----------|-----|
| Mental Health                            | 5.11%     | 18  |
| Physical Health                          | 3.98%     | 14  |
| Personal Relationship Employment         | 3.41%     | 12  |
| Living situation                         | 2.56%     | 9   |
| Drinking did not cause issues in my life | 92.05%    | 324 |
| Employment                               | 0.00%     | 0   |
| Total Respondents: 352                   |           |     |

**Q19 In the past 12 months did the use of drugs or other substance negatively impact any of the following (select all that apply):**

Answered: 355 Skipped: 90

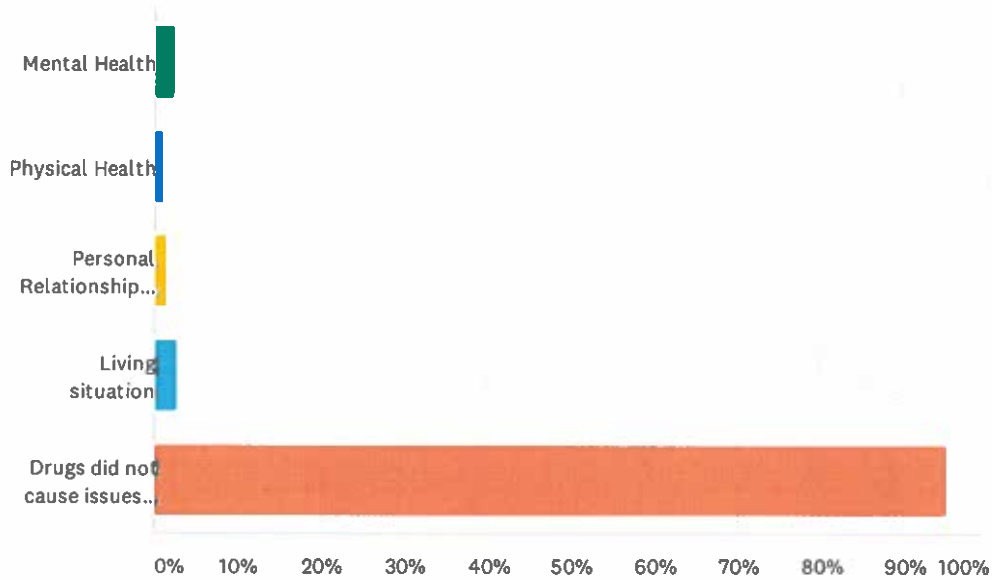

| ANSWER CHOICES                        | RESPONSES |     |
|---------------------------------------|-----------|-----|
| Mental Health                         | 2.25%     | 8   |
| Physical Health                       | 1.13%     | 4   |
| Personal Relationship Employment      | 1.41%     | 5   |
| Living situation                      | 2.82%     | 10  |
| Drugs did not cause issues in my life | 95.21%    | 338 |
| Total Respondents: 355                |           |     |

### Q20 In the past 12 months, have you experienced negative impacts (emotional, physical, financial etc.) due to any of the following:

Answered: 365 Skipped: 80

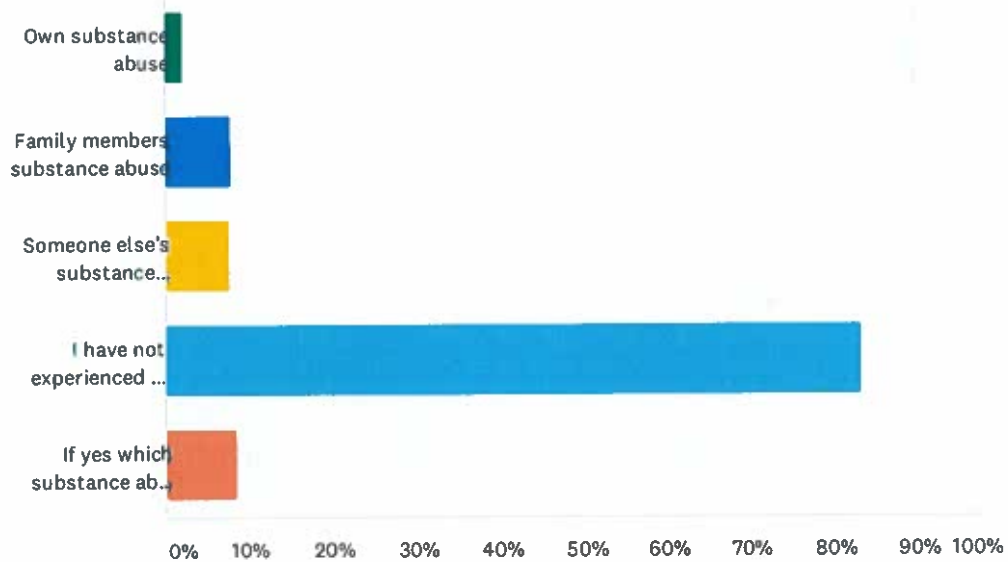

| ANSWER CHOICES                                                                             | RESPONSES |     |
|--------------------------------------------------------------------------------------------|-----------|-----|
| Own substance abuse                                                                        | 2.19%     | 8   |
| Family members substance abuse                                                             | 7.95%     | 29  |
| Someone else's substance abuse                                                             | 7.67%     | 28  |
| I have not experienced any negative impacts                                                | 83.56%    | 305 |
| If yes which substance abuse alcohol, tobacco, cannabis, opioid, prescription drugs, other | 8.49%     | 31  |
| <b>Total Respondents: 365</b>                                                              |           |     |

Almaguin Community Safety and Well Being Plan Survey 2020

| #  | IF YES WHICH SUBSTANCE ABUSE ALCOHOL, TOBACCO, CANNABIS, OPIOID, PRESCRIPTION DRUGS, OTHER | DATE               |
|----|--------------------------------------------------------------------------------------------|--------------------|
| 1  | alcohol and Crack Cocaine                                                                  | 5/26/2020 5:34 PM  |
| 2  | Opiod abuse                                                                                | 5/26/2020 11:17 AM |
| 3  | alcohol, drugs,                                                                            | 5/26/2020 7:37 AM  |
| 4  | Alcohol and cannabis                                                                       | 5/25/2020 10:15 PM |
| 5  | alcohol, tobacco                                                                           | 5/25/2020 9:06 PM  |
| 6  | Other                                                                                      | 5/25/2020 8:20 PM  |
| 7  | Alcohol                                                                                    | 5/25/2020 7:17 PM  |
| 8  | alcohol                                                                                    | 5/19/2020 4:03 PM  |
| 9  | Oxycontin                                                                                  | 5/16/2020 8:38 AM  |
| 10 | Alcohol, opioid                                                                            | 5/15/2020 6:14 PM  |
| 11 | Alcohol                                                                                    | 5/14/2020 11:22 AM |
| 12 | alcohol, drugs                                                                             | 5/14/2020 11:18 AM |
| 13 | Alcohol                                                                                    | 5/14/2020 10:47 AM |
| 14 | all of the above                                                                           | 5/13/2020 8:52 PM  |
| 15 | neighbor's use of alcohol and/or drugs                                                     | 5/13/2020 6:42 PM  |
| 16 | Alcohol                                                                                    | 5/13/2020 6:41 PM  |
| 17 | weight gain from alcohol                                                                   | 5/13/2020 4:01 PM  |
| 18 | Cannabis use by under aged youth                                                           | 5/13/2020 3:14 PM  |
| 19 | tobacco                                                                                    | 5/13/2020 1:11 PM  |
| 20 | Alcohol                                                                                    | 5/13/2020 12:42 PM |
| 21 | Alcohol                                                                                    | 5/13/2020 9:01 AM  |
| 22 | Alcohol                                                                                    | 5/13/2020 8:55 AM  |
| 23 | Alcohol , tobacco ,                                                                        | 5/12/2020 10:42 PM |
| 24 | Canabis                                                                                    | 5/12/2020 8:38 PM  |
| 25 | Alcohol                                                                                    | 5/12/2020 6:26 PM  |
| 26 | Alcohol and prescription meds                                                              | 5/12/2020 9:42 AM  |
| 27 | alcohol                                                                                    | 5/11/2020 10:30 PM |
| 28 | Cannabis                                                                                   | 5/11/2020 8:12 PM  |
| 29 | Alcohol                                                                                    | 5/11/2020 6:30 PM  |
| 30 | All the above excluding tobacco                                                            | 5/11/2020 5:06 PM  |
| 31 | Alcohol                                                                                    | 5/11/2020 3:49 PM  |

### Q21 Overall I feel I have family and friends I can rely on.

Answered: 381 Skipped: 64

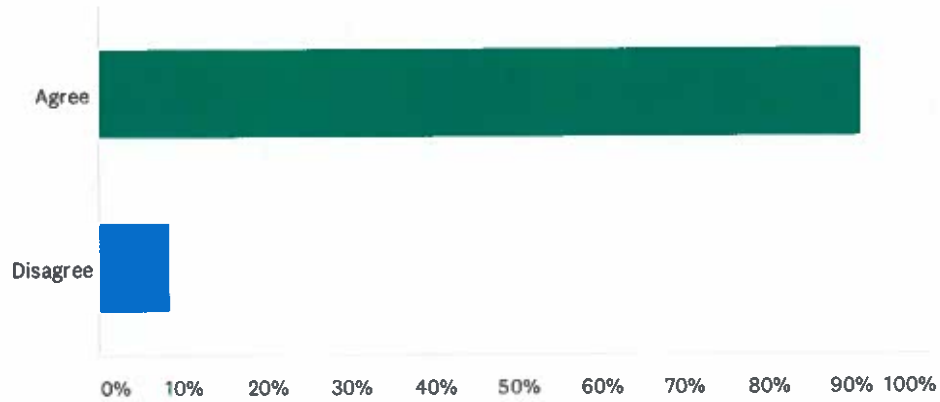

| ANSWER CHOICES | RESPONSES |     |
|----------------|-----------|-----|
| Agree          | 91.60%    | 349 |
| Disagree       | 8.40%     | 32  |
| TOTAL          |           | 381 |

## Q22 How do you prefer to socialize?

Answered: 384 Skipped: 61

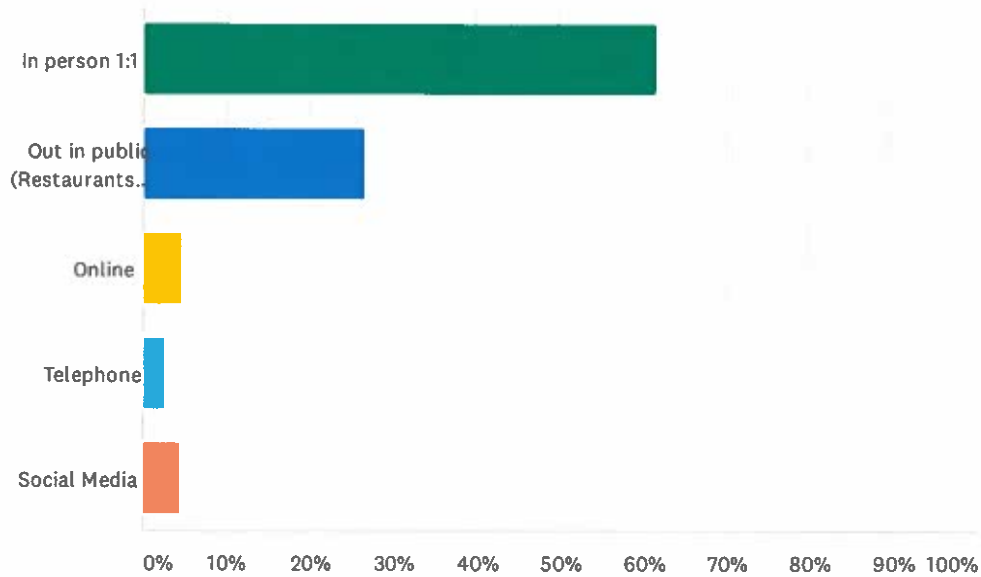

| ANSWER CHOICES                                       | RESPONSES |            |
|------------------------------------------------------|-----------|------------|
| In person 1:1                                        | 61.72%    | 237        |
| Out in public (Restaurants, events, activities etc.) | 26.56%    | 102        |
| Online                                               | 4.69%     | 18         |
| Telephone                                            | 2.60%     | 10         |
| Social Media                                         | 4.43%     | 17         |
| <b>TOTAL</b>                                         |           | <b>384</b> |

### Q23 Are there any programs, supports or services you wish were available in Almaguin for:

Answered: 264 Skipped: 181

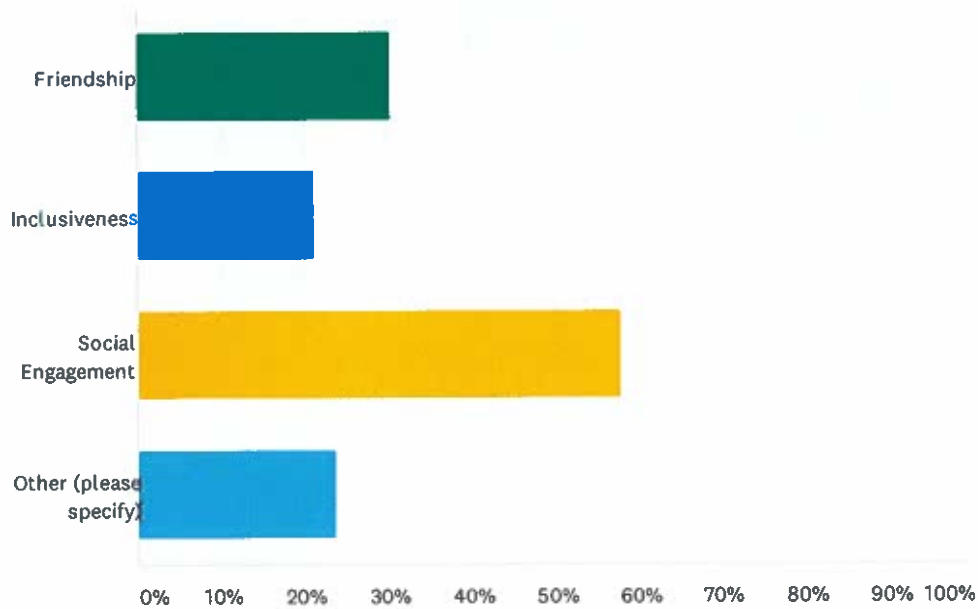

| ANSWER CHOICES         | RESPONSES |     |
|------------------------|-----------|-----|
| Friendship             | 30.30%    | 80  |
| Inclusiveness          | 21.21%    | 56  |
| Social Engagement      | 57.95%    | 153 |
| Other (please specify) | 23.86%    | 63  |
| Total Respondents: 264 |           |     |



## Almaguin Community Safety and Well Being Plan Survey 2020

| #  | OTHER (PLEASE SPECIFY)                                                                                                                                                                                                                                                                                                                                                                                                     | DATE               |
|----|----------------------------------------------------------------------------------------------------------------------------------------------------------------------------------------------------------------------------------------------------------------------------------------------------------------------------------------------------------------------------------------------------------------------------|--------------------|
| 1  | No                                                                                                                                                                                                                                                                                                                                                                                                                         | 6/6/2020 5:26 PM   |
| 2  | can't think of any at the moment                                                                                                                                                                                                                                                                                                                                                                                           | 5/29/2020 5:41 PM  |
| 3  | Something for children to build confidence and connect with other kids                                                                                                                                                                                                                                                                                                                                                     | 5/27/2020 6:27 PM  |
| 4  | Festivals, more accessible medical centre                                                                                                                                                                                                                                                                                                                                                                                  | 5/27/2020 6:08 PM  |
| 5  | A doctor                                                                                                                                                                                                                                                                                                                                                                                                                   | 5/27/2020 4:29 PM  |
| 6  | no                                                                                                                                                                                                                                                                                                                                                                                                                         | 5/26/2020 10:41 PM |
| 7  | more organized fitness classes during the summer for seniors besides golfing and walking: yoga, zumba                                                                                                                                                                                                                                                                                                                      | 5/26/2020 4:02 PM  |
| 8  | Nothing specific                                                                                                                                                                                                                                                                                                                                                                                                           | 5/26/2020 3:10 PM  |
| 9  | Something that addresses and improves seasonal vs local sentiment.                                                                                                                                                                                                                                                                                                                                                         | 5/26/2020 2:14 PM  |
| 10 | Integrity Commissioner                                                                                                                                                                                                                                                                                                                                                                                                     | 5/26/2020 7:37 AM  |
| 11 | more programs for kids. especially toddlers and babies and not during typical working hours for those parents who do work                                                                                                                                                                                                                                                                                                  | 5/26/2020 7:29 AM  |
| 12 | No                                                                                                                                                                                                                                                                                                                                                                                                                         | 5/25/2020 11:51 PM |
| 13 | Seniors                                                                                                                                                                                                                                                                                                                                                                                                                    | 5/25/2020 10:51 PM |
| 14 | Opportunities to learn new things/skills                                                                                                                                                                                                                                                                                                                                                                                   | 5/25/2020 7:17 PM  |
| 15 | gym                                                                                                                                                                                                                                                                                                                                                                                                                        | 5/25/2020 11:15 AM |
| 16 | Human Rights Tribunal; Integrity Commissioner; Credible Building Commission Officials                                                                                                                                                                                                                                                                                                                                      | 5/25/2020 10:15 AM |
| 17 | Community based volunteering                                                                                                                                                                                                                                                                                                                                                                                               | 5/25/2020 8:15 AM  |
| 18 | Special events such as Lobster Fest, air shows                                                                                                                                                                                                                                                                                                                                                                             | 5/19/2020 10:58 AM |
| 19 | More sports related activities                                                                                                                                                                                                                                                                                                                                                                                             | 5/18/2020 7:28 PM  |
| 20 | No                                                                                                                                                                                                                                                                                                                                                                                                                         | 5/18/2020 10:29 AM |
| 21 | Low impact aerobics for seniors / gardening info programs                                                                                                                                                                                                                                                                                                                                                                  | 5/18/2020 9:16 AM  |
| 22 | None                                                                                                                                                                                                                                                                                                                                                                                                                       | 5/17/2020 7:20 PM  |
| 23 | No                                                                                                                                                                                                                                                                                                                                                                                                                         | 5/17/2020 2:07 PM  |
| 24 | None of the above                                                                                                                                                                                                                                                                                                                                                                                                          | 5/17/2020 8:55 AM  |
| 25 | No                                                                                                                                                                                                                                                                                                                                                                                                                         | 5/16/2020 11:48 PM |
| 26 | a Gym                                                                                                                                                                                                                                                                                                                                                                                                                      | 5/16/2020 12:35 PM |
| 27 | Supportive housing with accessibility and LTC home.                                                                                                                                                                                                                                                                                                                                                                        | 5/16/2020 8:38 AM  |
| 28 | Available Family Physician                                                                                                                                                                                                                                                                                                                                                                                                 | 5/16/2020 6:17 AM  |
| 29 | more activities for young children (toddler age) that is not during the day, some parents do work                                                                                                                                                                                                                                                                                                                          | 5/15/2020 12:52 PM |
| 30 | None                                                                                                                                                                                                                                                                                                                                                                                                                       | 5/15/2020 11:14 AM |
| 31 | Evening fitness exercise classes, evening craft events, recreation activities during evening or weekends. Personal interest classes or courses like photography maybe even offered through a college, but held in Magnetawan. Night school programs for adults for learning and social interaction. There is very little recreation in Magnetawan for working people as most things are held during regular working hours. | 5/15/2020 1:32 AM  |
| 32 | continuing education programs                                                                                                                                                                                                                                                                                                                                                                                              | 5/14/2020 6:52 PM  |
| 33 | No                                                                                                                                                                                                                                                                                                                                                                                                                         | 5/14/2020 11:51 AM |
| 34 | Integrity Commissioner                                                                                                                                                                                                                                                                                                                                                                                                     | 5/14/2020 11:18 AM |

## Almaguin Community Safety and Well Being Plan Survey 2020

|    |                                                                                                                                                                                                                                                                                                                                                         |                    |
|----|---------------------------------------------------------------------------------------------------------------------------------------------------------------------------------------------------------------------------------------------------------------------------------------------------------------------------------------------------------|--------------------|
| 35 | Create a functional, accessible, secure volunteer information network for all of the programs, clubs and organizations that already exist.                                                                                                                                                                                                              | 5/13/2020 8:32 PM  |
| 36 | Swimming pool senior housing with balconies                                                                                                                                                                                                                                                                                                             | 5/13/2020 7:47 PM  |
| 37 | More of a community centre hub somewhere                                                                                                                                                                                                                                                                                                                | 5/13/2020 7:32 PM  |
| 38 | I don't really need anything at my age.                                                                                                                                                                                                                                                                                                                 | 5/13/2020 7:21 PM  |
| 39 | physical activity groups/clubs                                                                                                                                                                                                                                                                                                                          | 5/13/2020 6:42 PM  |
| 40 | Children/youth programs year round                                                                                                                                                                                                                                                                                                                      | 5/13/2020 6:39 PM  |
| 41 | Less of the "not from here" attitude                                                                                                                                                                                                                                                                                                                    | 5/13/2020 6:20 PM  |
| 42 | youth programs-basketball camp etc.                                                                                                                                                                                                                                                                                                                     | 5/13/2020 3:50 PM  |
| 43 | D.A.R.E., Police reaching out to youth programs                                                                                                                                                                                                                                                                                                         | 5/13/2020 3:14 PM  |
| 44 | Medical                                                                                                                                                                                                                                                                                                                                                 | 5/13/2020 11:35 AM |
| 45 | Entertainment                                                                                                                                                                                                                                                                                                                                           | 5/12/2020 10:42 PM |
| 46 | better ON-LINE service and access                                                                                                                                                                                                                                                                                                                       | 5/12/2020 9:57 PM  |
| 47 | I was very upset and disappointed on the messages on Downtown Magnetawan as well as some who live up there in terms of feeling unwelcome during COVID 19 even though I had been very cautious and had not been out of house in Brampton but unwelcome to come to my summer home where spend 6 months of the year. I do not live in the united states!!! | 5/12/2020 9:25 PM  |
| 48 | No                                                                                                                                                                                                                                                                                                                                                      | 5/12/2020 7:14 PM  |
| 49 | None                                                                                                                                                                                                                                                                                                                                                    | 5/12/2020 2:01 PM  |
| 50 | Not all problems are caused by substance abuse, yet, there are no mental health supports for those who were emotionally, mentally abused, or suffer PTSD from anything else.                                                                                                                                                                            | 5/12/2020 1:55 PM  |
| 51 | Ladies Hiking Group, Ladies Baseball League - guys have hockey                                                                                                                                                                                                                                                                                          | 5/12/2020 1:45 PM  |
| 52 | At the present time, I believe we need more help for mental health problems. Most of our physical needs can be met but much of it requires travel, or Ontario Telemedicine.                                                                                                                                                                             | 5/12/2020 12:47 PM |
| 53 | Medical                                                                                                                                                                                                                                                                                                                                                 | 5/12/2020 12:42 PM |
| 54 | Human Rights Tribunal                                                                                                                                                                                                                                                                                                                                   | 5/12/2020 11:33 AM |
| 55 | None                                                                                                                                                                                                                                                                                                                                                    | 5/12/2020 11:16 AM |
| 56 | More kids/youth programs.                                                                                                                                                                                                                                                                                                                               | 5/11/2020 11:21 PM |
| 57 | More postpartum supports                                                                                                                                                                                                                                                                                                                                | 5/11/2020 11:04 PM |
| 58 | more activities for children and young people                                                                                                                                                                                                                                                                                                           | 5/11/2020 8:55 PM  |
| 59 | Fitness centre                                                                                                                                                                                                                                                                                                                                          | 5/11/2020 7:54 PM  |
| 60 | Physical activities                                                                                                                                                                                                                                                                                                                                     | 5/11/2020 6:40 PM  |
| 61 | Adult sports                                                                                                                                                                                                                                                                                                                                            | 5/11/2020 5:20 PM  |
| 62 | Toddler 2+ programs                                                                                                                                                                                                                                                                                                                                     | 5/11/2020 4:24 PM  |
| 63 | Things for kids besides indoor sports                                                                                                                                                                                                                                                                                                                   | 5/11/2020 4:08 PM  |

### Q24 Do any of the following factors affect your ability to participate in recreation and leisure activities within your community?

Answered: 374 Skipped: 71

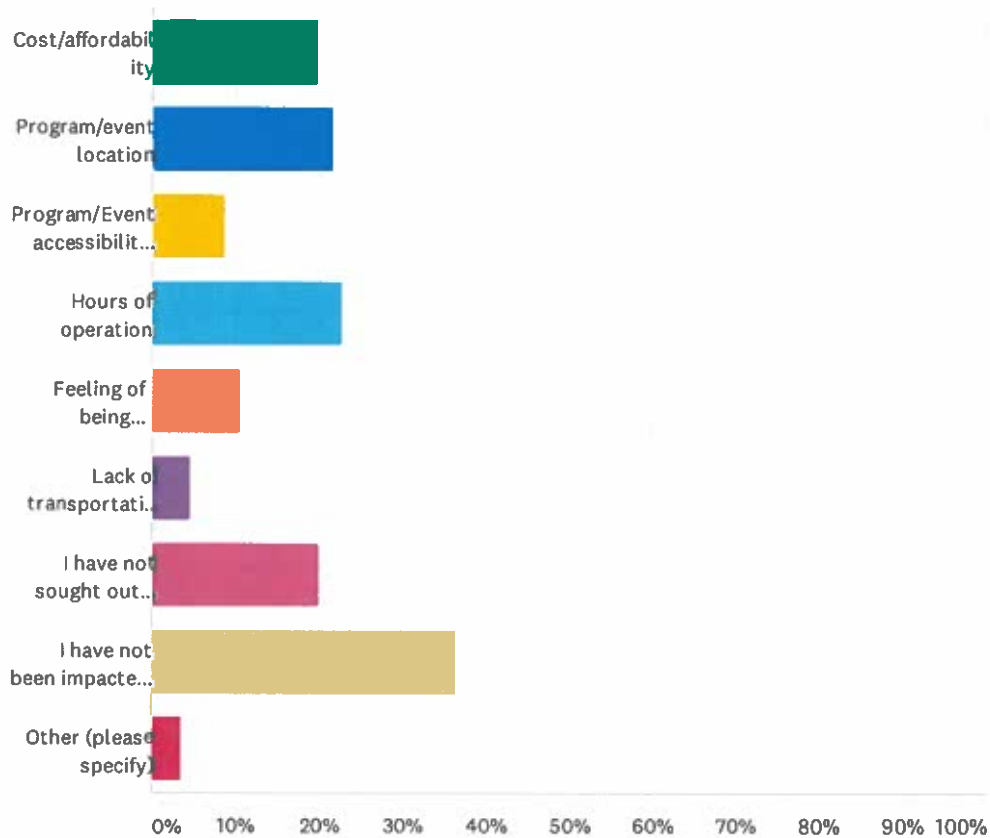

| ANSWER CHOICES                                 | RESPONSES |     |
|------------------------------------------------|-----------|-----|
| Cost/affordability                             | 19.79%    | 74  |
| Program/event location                         | 21.66%    | 81  |
| Program/Event accessibility                    | 8.82%     | 33  |
| Hours of operation                             | 22.73%    | 85  |
| Feeling of being unwelcome/judged in a program | 10.70%    | 40  |
| Lack of transportation to program              | 4.55%     | 17  |
| I have not sought out these programs           | 20.05%    | 75  |
| I have not been impacted by these factors      | 36.63%    | 137 |
| Other (please specify)                         | 3.48%     | 13  |
| Total Respondents: 374                         |           |     |

Almaguin Community Safety and Well Being Plan Survey 2020

| #  | OTHER (PLEASE SPECIFY)                                                                                                                                                                 | DATE               |
|----|----------------------------------------------------------------------------------------------------------------------------------------------------------------------------------------|--------------------|
| 1  | Shy and anxious                                                                                                                                                                        | 5/26/2020 11:51 AM |
| 2  | Lack of programs                                                                                                                                                                       | 5/25/2020 8:20 PM  |
| 3  | Awareness about where &when programs ate offered                                                                                                                                       | 5/25/2020 7:17 PM  |
| 4  | Our community doesn't offer programs                                                                                                                                                   | 5/25/2020 10:36 AM |
| 5  | Recreation programs are mostly in North Bay or Huntsville, something central would be great.                                                                                           | 5/25/2020 10:00 AM |
| 6  | No interest in offered activities                                                                                                                                                      | 5/18/2020 7:28 PM  |
| 7  | Knowledge of programs.                                                                                                                                                                 | 5/17/2020 4:01 PM  |
| 8  | Other than a few library events the recreation is always scheduled m-f during regular work hours so I can not participate due to working out of town. Very little for adults to join . | 5/15/2020 1:32 AM  |
| 9  | The lack of recreation and leisure activities in our area                                                                                                                              | 5/14/2020 12:02 PM |
| 10 | not available                                                                                                                                                                          | 5/13/2020 3:50 PM  |
| 11 | There aren't really an activities offered, if there are they are not advertised at all                                                                                                 | 5/13/2020 11:40 AM |
| 12 | covin 19 isolation                                                                                                                                                                     | 5/12/2020 12:47 PM |
| 13 | Being unaware when events are being held. Need a central place to look at to know of events happening.                                                                                 | 5/11/2020 11:21 PM |

**Q25 Are there any recreation or leisure programs supports or services you wish were available in your community?**

Answered: 180 Skipped: 265

## Almaguin Community Safety and Well Being Plan Survey 2020

| #  | RESPONSES                                                                                                                                                                                                                                                               | DATE               |
|----|-------------------------------------------------------------------------------------------------------------------------------------------------------------------------------------------------------------------------------------------------------------------------|--------------------|
| 1  | I know there are some short distance walking trails, but I would really appreciate some trails that are longer. While it's nice to go to Algonquin Park to hike, my first preference would be to stay local. Perhaps some outdoor fitness classes during summer months. | 6/7/2020 5:01 AM   |
| 2  | No                                                                                                                                                                                                                                                                      | 6/6/2020 5:26 PM   |
| 3  | Cycling programs                                                                                                                                                                                                                                                        | 6/6/2020 10:24 AM  |
| 4  | There has been a great amount of new programs in Burk's Falls over the last few years. I am always open to new opportunities for active lifestyle though.                                                                                                               | 6/5/2020 11:35 AM  |
| 5  | Choir                                                                                                                                                                                                                                                                   | 6/4/2020 11:01 AM  |
| 6  | Yes                                                                                                                                                                                                                                                                     | 6/3/2020 3:53 PM   |
| 7  | More sports events, festivals or community building events.                                                                                                                                                                                                             | 6/3/2020 2:01 PM   |
| 8  | More recreation programs for young children. Information more readily available about program dates and sign ups on village website or fb page                                                                                                                          | 6/3/2020 1:02 AM   |
| 9  | swimming lessons                                                                                                                                                                                                                                                        | 6/1/2020 8:59 PM   |
| 10 | A 24 hours fitness facility would be great. Very hard to stay in shape in the winter months in Kearney aside from walking.                                                                                                                                              | 5/31/2020 10:58 PM |
| 11 | No                                                                                                                                                                                                                                                                      | 5/31/2020 10:33 PM |
| 12 | not at the moment                                                                                                                                                                                                                                                       | 5/29/2020 5:41 PM  |
| 13 | Bike paths; gym classes (circuit, etc.); better hiking; community fitness centre.                                                                                                                                                                                       | 5/29/2020 9:02 AM  |
| 14 | family fun nights including games movies etc                                                                                                                                                                                                                            | 5/28/2020 8:29 PM  |
| 15 | Beach access re parking and amenities around town beaches could be improved to attract tourism                                                                                                                                                                          | 5/28/2020 9:07 AM  |
| 16 | Not that I can think of right now                                                                                                                                                                                                                                       | 5/27/2020 9:02 PM  |
| 17 | Adult soccer, adult hockey                                                                                                                                                                                                                                              | 5/27/2020 6:41 PM  |
| 18 | Swim lessons in the winter and better hours in the summer , soccer for adults and kids                                                                                                                                                                                  | 5/27/2020 6:27 PM  |
| 19 | No                                                                                                                                                                                                                                                                      | 5/27/2020 6:25 PM  |
| 20 | Old-timers' hockey, gym                                                                                                                                                                                                                                                 | 5/27/2020 10:20 AM |
| 21 | no                                                                                                                                                                                                                                                                      | 5/26/2020 10:41 PM |
| 22 | Tennis                                                                                                                                                                                                                                                                  | 5/26/2020 5:34 PM  |
| 23 | Indoor kids playground                                                                                                                                                                                                                                                  | 5/26/2020 4:55 PM  |
| 24 | require summer season accessibility for seasonal residents. Programs tend to end in June and begin in Sept                                                                                                                                                              | 5/26/2020 4:02 PM  |
| 25 | Not at this time                                                                                                                                                                                                                                                        | 5/26/2020 3:10 PM  |
| 26 | Swimming lessons for grandchild.                                                                                                                                                                                                                                        | 5/26/2020 2:51 PM  |
| 27 | Gym / classes                                                                                                                                                                                                                                                           | 5/26/2020 2:14 PM  |
| 28 | more children sports, such as martial arts. More swimming lessons, etc.                                                                                                                                                                                                 | 5/26/2020 12:59 PM |
| 29 | Maybe little classes for different things everyday and making it known to the community. Advertising it more                                                                                                                                                            | 5/26/2020 11:51 AM |
| 30 | More activities of every kind and age group                                                                                                                                                                                                                             | 5/26/2020 10:01 AM |
| 31 | SWIMMING!! We need a swimming pool and gym in Burks falls!!                                                                                                                                                                                                             | 5/26/2020 9:43 AM  |
| 32 | Yes it would be great if we had a public pool and activity building. I'm sure a lot of people would access this from around the area.                                                                                                                                   | 5/26/2020 8:48 AM  |

## Almaguin Community Safety and Well Being Plan Survey 2020

|    |                                                                                                                                                                                                                                                                                                                                                                                                                                                                                                                                                                                                                                                                                          |                    |
|----|------------------------------------------------------------------------------------------------------------------------------------------------------------------------------------------------------------------------------------------------------------------------------------------------------------------------------------------------------------------------------------------------------------------------------------------------------------------------------------------------------------------------------------------------------------------------------------------------------------------------------------------------------------------------------------------|--------------------|
| 33 | There is nothing available here due to the abuse of the equipment and facilities. The leadership in the community is not there and the level of understanding of basic common law is completely lost. The rudeness of people towards the disabled, the elderly or the mentally challenged is absolutely disgusting. As if they were better than anyone else. The bullies - just a bunch of low class drunks who grew up to be just a bunch of low class drunks and had a bunch of kids who are just like them. Once upon a time a really wonderful place is now a disgusting pile of festering scum heaped in corruption, deceit, fraud and two-faced liars hooked on drugs and alcohol. | 5/26/2020 7:37 AM  |
| 34 | activities for toddlers and babies at a time not during typical working hours                                                                                                                                                                                                                                                                                                                                                                                                                                                                                                                                                                                                            | 5/26/2020 7:29 AM  |
| 35 | No                                                                                                                                                                                                                                                                                                                                                                                                                                                                                                                                                                                                                                                                                       | 5/25/2020 11:51 PM |
| 36 | Walking track, paved bicycle trails                                                                                                                                                                                                                                                                                                                                                                                                                                                                                                                                                                                                                                                      | 5/25/2020 10:51 PM |
| 37 | Fitness in Fitness studio                                                                                                                                                                                                                                                                                                                                                                                                                                                                                                                                                                                                                                                                | 5/25/2020 10:15 PM |
| 38 | There are not many social recreation programs at all                                                                                                                                                                                                                                                                                                                                                                                                                                                                                                                                                                                                                                     | 5/25/2020 8:20 PM  |
| 39 | Fitness/exercise, yoga, walking/running, swim, crafting, book club, dance, cooking, tai chi, meditation chi gong, community garden, young and old groups                                                                                                                                                                                                                                                                                                                                                                                                                                                                                                                                 | 5/25/2020 7:17 PM  |
| 40 | None that I can think of at the moment                                                                                                                                                                                                                                                                                                                                                                                                                                                                                                                                                                                                                                                   | 5/25/2020 7:12 PM  |
| 41 | Anything! There's hardly any leisure programs available.                                                                                                                                                                                                                                                                                                                                                                                                                                                                                                                                                                                                                                 | 5/25/2020 6:54 PM  |
| 42 | hiking group one stop information access to this type of services                                                                                                                                                                                                                                                                                                                                                                                                                                                                                                                                                                                                                        | 5/25/2020 5:02 PM  |
| 43 | Swimming pool in the winter                                                                                                                                                                                                                                                                                                                                                                                                                                                                                                                                                                                                                                                              | 5/25/2020 12:14 PM |
| 44 | gym                                                                                                                                                                                                                                                                                                                                                                                                                                                                                                                                                                                                                                                                                      | 5/25/2020 11:15 AM |
| 45 | More community programs for children and youth                                                                                                                                                                                                                                                                                                                                                                                                                                                                                                                                                                                                                                           | 5/25/2020 10:54 AM |
| 46 | A recreation centre year round with a pool and workout area                                                                                                                                                                                                                                                                                                                                                                                                                                                                                                                                                                                                                              | 5/25/2020 10:36 AM |
| 47 | Need proper organization and qualified program leaders and developers.                                                                                                                                                                                                                                                                                                                                                                                                                                                                                                                                                                                                                   | 5/25/2020 10:15 AM |
| 48 | Any programs available in the community would be great, most recreation or leisure programs are only available in the larger urban areas like North Bay or Huntsville.                                                                                                                                                                                                                                                                                                                                                                                                                                                                                                                   | 5/25/2020 10:00 AM |
| 49 | Better dressing rooms at the S.S.J. Arena.                                                                                                                                                                                                                                                                                                                                                                                                                                                                                                                                                                                                                                               | 5/19/2020 6:40 PM  |
| 50 | Programs are available but sometimes I and others do not access them as much as we should                                                                                                                                                                                                                                                                                                                                                                                                                                                                                                                                                                                                | 5/19/2020 4:03 PM  |
| 51 | Youth and Senior programs.                                                                                                                                                                                                                                                                                                                                                                                                                                                                                                                                                                                                                                                               | 5/19/2020 12:21 PM |
| 52 | Tennis courts,                                                                                                                                                                                                                                                                                                                                                                                                                                                                                                                                                                                                                                                                           | 5/19/2020 10:58 AM |
| 53 | exercise classes in the evening                                                                                                                                                                                                                                                                                                                                                                                                                                                                                                                                                                                                                                                          | 5/19/2020 7:43 AM  |
| 54 | No                                                                                                                                                                                                                                                                                                                                                                                                                                                                                                                                                                                                                                                                                       | 5/18/2020 11:47 PM |
| 55 | Gym or sports activities                                                                                                                                                                                                                                                                                                                                                                                                                                                                                                                                                                                                                                                                 | 5/18/2020 7:28 PM  |
| 56 | Boat launches                                                                                                                                                                                                                                                                                                                                                                                                                                                                                                                                                                                                                                                                            | 5/18/2020 10:29 AM |
| 57 | any programs would help someone in my community .                                                                                                                                                                                                                                                                                                                                                                                                                                                                                                                                                                                                                                        | 5/18/2020 9:16 AM  |
| 58 | No                                                                                                                                                                                                                                                                                                                                                                                                                                                                                                                                                                                                                                                                                       | 5/17/2020 7:20 PM  |
| 59 | Archery, cards, darts, yoga, fitness, etc.                                                                                                                                                                                                                                                                                                                                                                                                                                                                                                                                                                                                                                               | 5/17/2020 4:01 PM  |
| 60 | adult baseball/ softball                                                                                                                                                                                                                                                                                                                                                                                                                                                                                                                                                                                                                                                                 | 5/17/2020 3:13 PM  |
| 61 | No                                                                                                                                                                                                                                                                                                                                                                                                                                                                                                                                                                                                                                                                                       | 5/17/2020 2:07 PM  |
| 62 | No                                                                                                                                                                                                                                                                                                                                                                                                                                                                                                                                                                                                                                                                                       | 5/17/2020 8:55 AM  |
| 63 | continue the excercise program at Kearney Community Center More walking trails                                                                                                                                                                                                                                                                                                                                                                                                                                                                                                                                                                                                           | 5/17/2020 8:12 AM  |
| 64 | No                                                                                                                                                                                                                                                                                                                                                                                                                                                                                                                                                                                                                                                                                       | 5/16/2020 6:53 PM  |
| 65 | Indoor swimming pool.                                                                                                                                                                                                                                                                                                                                                                                                                                                                                                                                                                                                                                                                    | 5/16/2020 5:32 PM  |

## Almaguin Community Safety and Well Being Plan Survey 2020

|    |                                                                                                                                                                                                                                                                   |                    |
|----|-------------------------------------------------------------------------------------------------------------------------------------------------------------------------------------------------------------------------------------------------------------------|--------------------|
| 66 | Perhaps a drop in centre for socializing.                                                                                                                                                                                                                         | 5/16/2020 2:52 PM  |
| 67 | Guided hikes,                                                                                                                                                                                                                                                     | 5/16/2020 9:21 AM  |
| 68 | Better library and public transportation to Sundridge, Huntsville and North Bay.                                                                                                                                                                                  | 5/16/2020 8:38 AM  |
| 69 | I think there is some of all of the above available                                                                                                                                                                                                               | 5/16/2020 6:17 AM  |
| 70 | Swimming lessons                                                                                                                                                                                                                                                  | 5/15/2020 1:05 PM  |
| 71 | programs for toddlers and smaller that are not during working hours (singing, yoga, dance, sports, art class ect) as a lot of parents work, and or more of these programs for small kids                                                                          | 5/15/2020 12:52 PM |
| 72 | No                                                                                                                                                                                                                                                                | 5/15/2020 11:14 AM |
| 73 | karate, basketball, swimming lessons                                                                                                                                                                                                                              | 5/15/2020 10:33 AM |
| 74 | No                                                                                                                                                                                                                                                                | 5/15/2020 8:12 AM  |
| 75 | College courses, craft classes, photography courses, dancing, evening exercise or Zumba, yoga, fitness classes, evening badminton, volleyball, for adults Evening or weekend sports for children like soccer, lacrosse, pick up hockey, dance, anything, baseball | 5/15/2020 1:32 AM  |
| 76 | yoga                                                                                                                                                                                                                                                              | 5/14/2020 10:56 PM |
| 77 | Wheelchair access to beachfront at Lake Bernard.                                                                                                                                                                                                                  | 5/14/2020 8:00 PM  |
| 78 | Bridge.                                                                                                                                                                                                                                                           | 5/14/2020 6:52 PM  |
| 79 | Work out classes for women                                                                                                                                                                                                                                        | 5/14/2020 12:02 PM |
| 80 | I wish we had a place like 25o Clark that ran all different programs for adults, seniors and children.                                                                                                                                                            | 5/14/2020 12:02 PM |
| 81 | More programming for kids                                                                                                                                                                                                                                         | 5/14/2020 11:22 AM |
| 82 | We need law and order and proper enforcement before we waste any more tax payer dollars to introduce leisure programs and support.                                                                                                                                | 5/14/2020 11:18 AM |
| 83 | Clearly marked walking trails for seniors.                                                                                                                                                                                                                        | 5/14/2020 10:51 AM |
| 84 | Swimming                                                                                                                                                                                                                                                          | 5/14/2020 10:47 AM |
| 85 | More access to services for all ages                                                                                                                                                                                                                              | 5/14/2020 9:09 AM  |
| 86 | community pool                                                                                                                                                                                                                                                    | 5/14/2020 9:03 AM  |
| 87 | no                                                                                                                                                                                                                                                                | 5/14/2020 7:33 AM  |
| 88 | More need to be in evening                                                                                                                                                                                                                                        | 5/14/2020 7:24 AM  |
| 89 | Afternoon exercise, yoga or maybe tai chi class. A keep moving/stay healthy program type thing.                                                                                                                                                                   | 5/14/2020 1:03 AM  |
| 90 | Gym to workout and physical training classes. Indoor pool.                                                                                                                                                                                                        | 5/13/2020 10:22 PM |
| 91 | No                                                                                                                                                                                                                                                                | 5/13/2020 9:51 PM  |
| 92 | Nothing we don't already have                                                                                                                                                                                                                                     | 5/13/2020 9:17 PM  |
| 93 | Walking trails and parks.                                                                                                                                                                                                                                         | 5/13/2020 8:58 PM  |
| 94 | Tai Chi, but not on a weekday morning, something that acknowledges not everyone in this town is a senior citizen. Family yoga would also be cool. Keep up the softball league...                                                                                  | 5/13/2020 8:32 PM  |
| 95 | Yoga. Taichi. Euchre. Book Club. Pole Walking. Guided Walks. Swimming. Canoeing, Kayaking. Cooking.                                                                                                                                                               | 5/13/2020 7:58 PM  |
| 96 | Swimming pool heated                                                                                                                                                                                                                                              | 5/13/2020 7:47 PM  |
| 97 | Baseball for the kids                                                                                                                                                                                                                                             | 5/13/2020 7:46 PM  |
| 98 | More recreational programs                                                                                                                                                                                                                                        | 5/13/2020 7:32 PM  |
| 99 | none thanks                                                                                                                                                                                                                                                       | 5/13/2020 7:21 PM  |



## Almaguin Community Safety and Well Being Plan Survey 2020

|     |                                                                                                                                                                                                                                                                           |                    |
|-----|---------------------------------------------------------------------------------------------------------------------------------------------------------------------------------------------------------------------------------------------------------------------------|--------------------|
| 100 | physical activity: walking, hiking, cycling, healthy cooking                                                                                                                                                                                                              | 5/13/2020 6:42 PM  |
| 101 | Skiing cross country, outdoor skating, tennis, swimming lessons                                                                                                                                                                                                           | 5/13/2020 6:39 PM  |
| 102 | Youth sports programs                                                                                                                                                                                                                                                     | 5/13/2020 6:22 PM  |
| 103 | Indoor pool, indoor walking track a clearer way of knowing about programs offered in the community- eg dedicated monthly bulletin board notices                                                                                                                           | 5/13/2020 6:20 PM  |
| 104 | A safe safe place to swim                                                                                                                                                                                                                                                 | 5/13/2020 5:45 PM  |
| 105 | Bike Trails, walking trails, outdoor rec area                                                                                                                                                                                                                             | 5/13/2020 5:37 PM  |
| 106 | More exercise classes or a gym like Good Life that offers classes to all ages                                                                                                                                                                                             | 5/13/2020 3:59 PM  |
| 107 | youth camps or events                                                                                                                                                                                                                                                     | 5/13/2020 3:50 PM  |
| 108 | Music, Martial Arts                                                                                                                                                                                                                                                       | 5/13/2020 3:14 PM  |
| 109 | The kids in this town need something to go to or do, there's nothing for teenagers                                                                                                                                                                                        | 5/13/2020 12:41 PM |
| 110 | More walking trails                                                                                                                                                                                                                                                       | 5/13/2020 11:47 AM |
| 111 | We would like to have a proper gym and pool, a centre that can be used for sports (indoor/outdoor) a long boardwalk along the lake would be nice to walk on, or just more trails or safer road ways so we don't have to walk on the road just to get into town            | 5/13/2020 11:40 AM |
| 112 | Activities for our arena area. Pickle ball, badminton, basketball nets, tennis court. After school activities for school age children                                                                                                                                     | 5/13/2020 10:16 AM |
| 113 | Drop in centre                                                                                                                                                                                                                                                            | 5/13/2020 9:56 AM  |
| 114 | Yes.....programs like 250 Clark Street in Powassan has. They have amazing intellectual, cultural, and physical activities for ALL ages.                                                                                                                                   | 5/13/2020 9:50 AM  |
| 115 | More programming for middle aged women                                                                                                                                                                                                                                    | 5/13/2020 9:32 AM  |
| 116 | More senior programs and activities to keep fitness up and hobbies and crafts                                                                                                                                                                                             | 5/13/2020 9:32 AM  |
| 117 | more senior activities                                                                                                                                                                                                                                                    | 5/13/2020 9:20 AM  |
| 118 | Pickel ball, hiking, photo club                                                                                                                                                                                                                                           | 5/13/2020 8:25 AM  |
| 119 | Community gardening , hiking trail , Health Spa , Spiritual Centre for arts crafts , Dances for teens , Baseball etc . Spiritual group for teens focusing on mental health implementing arts crafts , Community picnics for seniors . Transportation to and from events . | 5/12/2020 10:42 PM |
| 120 | N/A                                                                                                                                                                                                                                                                       | 5/12/2020 9:29 PM  |
| 121 | Not sure                                                                                                                                                                                                                                                                  | 5/12/2020 8:38 PM  |
| 122 | No                                                                                                                                                                                                                                                                        | 5/12/2020 7:14 PM  |
| 123 | I would love to see a work out space that is affordable and available to all in my community. A safe option that could be utilized all year long, especially our lengthy winter season. Great for mental and physical well being.                                         | 5/12/2020 3:27 PM  |
| 124 | No                                                                                                                                                                                                                                                                        | 5/12/2020 2:29 PM  |
| 125 | Biking events                                                                                                                                                                                                                                                             | 5/12/2020 2:10 PM  |
| 126 | more team sport leagues                                                                                                                                                                                                                                                   | 5/12/2020 2:05 PM  |
| 127 | None                                                                                                                                                                                                                                                                      | 5/12/2020 2:01 PM  |
| 128 | Tai Chi, Photography, Genealogy                                                                                                                                                                                                                                           | 5/12/2020 1:55 PM  |
| 129 | Activities for ladies - i.e. hiking, baseball                                                                                                                                                                                                                             | 5/12/2020 1:45 PM  |
| 130 | Public gym.                                                                                                                                                                                                                                                               | 5/12/2020 1:44 PM  |
| 131 | more recreational programs on weekends. It seems all the rec programs are during the week only. That's a problem for those who work                                                                                                                                       | 5/12/2020 1:37 PM  |

## Almaguin Community Safety and Well Being Plan Survey 2020

|     |                                                                                                                                                                                                                |                    |
|-----|----------------------------------------------------------------------------------------------------------------------------------------------------------------------------------------------------------------|--------------------|
| 132 | Exercise classes to be continued at the community centre                                                                                                                                                       | 5/12/2020 1:05 PM  |
| 133 | My needs are covered by what's here.                                                                                                                                                                           | 5/12/2020 12:47 PM |
| 134 | no                                                                                                                                                                                                             | 5/12/2020 12:47 PM |
| 135 | More programs for seniors and more activities for teenagers                                                                                                                                                    | 5/12/2020 12:39 PM |
| 136 | Fitness centre                                                                                                                                                                                                 | 5/12/2020 12:39 PM |
| 137 | Yes, but the substance abuse in this Village makes it impossible to even be able to enjoy 5 minutes of peace in your own backyard.                                                                             | 5/12/2020 11:33 AM |
| 138 | Ball room dance                                                                                                                                                                                                | 5/12/2020 11:16 AM |
| 139 | Any?                                                                                                                                                                                                           | 5/12/2020 11:09 AM |
| 140 | Gym - workout facility.                                                                                                                                                                                        | 5/12/2020 10:19 AM |
| 141 | Dunno                                                                                                                                                                                                          | 5/12/2020 9:01 AM  |
| 142 | yoga, table tennis, dodge ball                                                                                                                                                                                 | 5/12/2020 8:53 AM  |
| 143 | gym                                                                                                                                                                                                            | 5/12/2020 8:17 AM  |
| 144 | alot more                                                                                                                                                                                                      | 5/11/2020 11:35 PM |
| 145 | Exercise equipment                                                                                                                                                                                             | 5/11/2020 10:27 PM |
| 146 | Exercise program properly marked walking trails social parties get-togethers utilizing our community centres more                                                                                              | 5/11/2020 10:09 PM |
| 147 | better space or small room to rent for social events like birthdays etc                                                                                                                                        | 5/11/2020 9:33 PM  |
| 148 | Exercise class Nutrition class assistance                                                                                                                                                                      | 5/11/2020 9:16 PM  |
| 149 | More kids events                                                                                                                                                                                               | 5/11/2020 9:09 PM  |
| 150 | walking trails without atv use                                                                                                                                                                                 | 5/11/2020 9:09 PM  |
| 151 | Swimming lessons                                                                                                                                                                                               | 5/11/2020 8:37 PM  |
| 152 | None                                                                                                                                                                                                           | 5/11/2020 8:37 PM  |
| 153 | No                                                                                                                                                                                                             | 5/11/2020 8:24 PM  |
| 154 | Adult fitness programs                                                                                                                                                                                         | 5/11/2020 8:12 PM  |
| 155 | Fitness centre                                                                                                                                                                                                 | 5/11/2020 7:54 PM  |
| 156 | I lived in Ottawa for many years and one of the best resources there would be their dog parks (Bruce Pit, Conroy). I got exercise and I was able to socialize without becoming overwhelmed by cost, time, etc. | 5/11/2020 5:47 PM  |
| 157 | More public skating hour options, base ball, t ball, swimming lessons                                                                                                                                          | 5/11/2020 5:30 PM  |
| 158 | Adult hockey Adult soccer                                                                                                                                                                                      | 5/11/2020 5:20 PM  |
| 159 | Multi cultural inclusion. Neighbours fly confederate flags on the 518.                                                                                                                                         | 5/11/2020 5:12 PM  |
| 160 | A gym, fitness centre, pool would be nice                                                                                                                                                                      | 5/11/2020 5:06 PM  |
| 161 | dog parks, family dances and or events                                                                                                                                                                         | 5/11/2020 5:03 PM  |
| 162 | I find most are geared towards seniors or seasonal people but I have a 8-4 monday - Friday job so for the most part I cant participate in anything because things are usually scheduled during the day.        | 5/11/2020 5:01 PM  |
| 163 | Activities for ages 45 to 60                                                                                                                                                                                   | 5/11/2020 5:01 PM  |
| 164 | More space/ options for children's physical activity                                                                                                                                                           | 5/11/2020 5:00 PM  |
| 165 | ,                                                                                                                                                                                                              | 5/11/2020 4:47 PM  |
| 166 | I was told Archery was previously available in Burk's Falls, I would love to attend if it becomes                                                                                                              | 5/11/2020 4:37 PM  |

Almaguin Community Safety and Well Being Plan Survey 2020

|     |                                                                                                                                                                                         |                   |
|-----|-----------------------------------------------------------------------------------------------------------------------------------------------------------------------------------------|-------------------|
|     | available again. :)                                                                                                                                                                     |                   |
| 167 | Yoga. Craft group                                                                                                                                                                       | 5/11/2020 4:35 PM |
| 168 | Art classes for beginners, fitness classes                                                                                                                                              | 5/11/2020 4:33 PM |
| 169 | Toddler 2+ years old More mom 2 mom groups                                                                                                                                              | 5/11/2020 4:24 PM |
| 170 | physical                                                                                                                                                                                | 5/11/2020 4:13 PM |
| 171 | Gym's                                                                                                                                                                                   | 5/11/2020 4:06 PM |
| 172 | No - these programs are not a factor unless you have a thriving downtown and businesses otherwise I would rather see my tax dollar go to ventures that economically support the Village | 5/11/2020 4:06 PM |
| 173 | Gym                                                                                                                                                                                     | 5/11/2020 4:04 PM |
| 174 | It would be nice to have a salt-water public pool available as I am allergic to Chlorine and miss swimming as an exercise.                                                              | 5/11/2020 4:02 PM |
| 175 | Court games (tennis, squash), clubs                                                                                                                                                     | 5/11/2020 3:49 PM |
| 176 | anything would be good                                                                                                                                                                  | 5/11/2020 3:45 PM |
| 177 | Adult recreation programs after 7 pm at night                                                                                                                                           | 5/11/2020 3:43 PM |
| 178 | No                                                                                                                                                                                      | 5/11/2020 3:38 PM |
| 179 | pool, splash pad, improved baseball field, improved skate park,                                                                                                                         | 5/11/2020 3:34 PM |
| 180 | gym                                                                                                                                                                                     | 5/11/2020 3:31 PM |

**Q26 Have you ever avoided seeking help or obtaining support in your community for any of the following due to embarrassment, fear or presumed stigma (select all that apply):**

Answered: 361 Skipped: 84

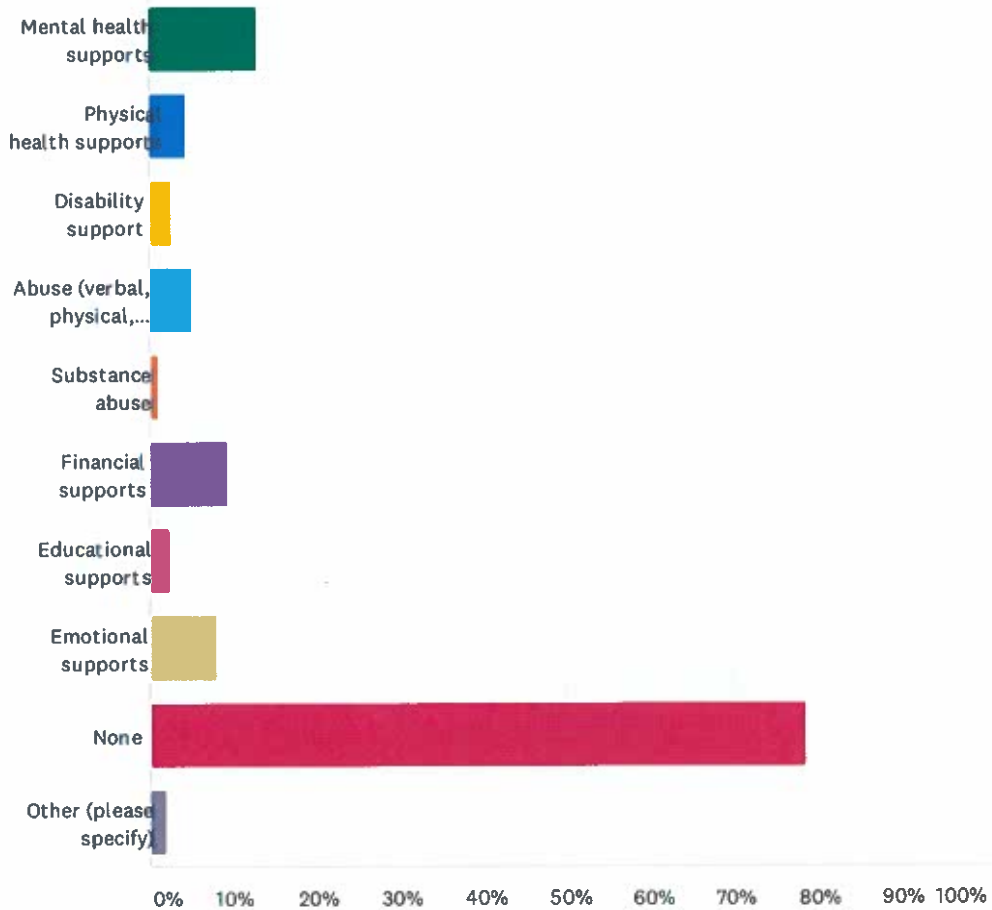

Almaguin Community Safety and Well Being Plan Survey 2020

| ANSWER CHOICES                   | RESPONSES |     |
|----------------------------------|-----------|-----|
| Mental health supports           | 13.02%    | 47  |
| Physical health supports         | 4.43%     | 16  |
| Disability support               | 2.49%     | 9   |
| Abuse (verbal, physical, sexual) | 4.99%     | 18  |
| Substance abuse                  | 1.11%     | 4   |
| Financial supports               | 9.14%     | 33  |
| Educational supports             | 2.22%     | 8   |
| Emotional supports               | 8.03%     | 29  |
| None                             | 78.67%    | 284 |
| Other (please specify)           | 1.94%     | 7   |
| Total Respondents: 361           |           |     |

| # | OTHER (PLEASE SPECIFY)                                                                                                                                                                                                                                               | DATE               |
|---|----------------------------------------------------------------------------------------------------------------------------------------------------------------------------------------------------------------------------------------------------------------------|--------------------|
| 1 | I do not seek any support in the community as I feel completely unwelcome, and a great deal of discrimination because of my age, and gender.                                                                                                                         | 5/26/2020 7:37 AM  |
| 2 | ZERO confidence in municipal governance - lack of integrity; due diligence; racism; discrimination; misogynistic; aggressive, rude behaviour; screaming and yelling at people; threatening physical harm; elderly abuse. Drug abuse, alcohol abuse on display daily. | 5/25/2020 10:15 AM |
| 3 | Outsider                                                                                                                                                                                                                                                             | 5/18/2020 10:29 AM |
| 4 | Corruption; deceit, fraud. Vandalism. Character defamation.                                                                                                                                                                                                          | 5/14/2020 11:18 AM |
| 5 | Anonymity                                                                                                                                                                                                                                                            | 5/13/2020 6:39 PM  |
| 6 | H                                                                                                                                                                                                                                                                    | 5/13/2020 4:04 PM  |
| 7 | Corruption; deceit, fraud. Vandalism. Character defamation.                                                                                                                                                                                                          | 5/12/2020 11:33 AM |

### Q27 Which statement best describe your current work situation (prior to COVID)?

Answered: 360 Skipped: 85

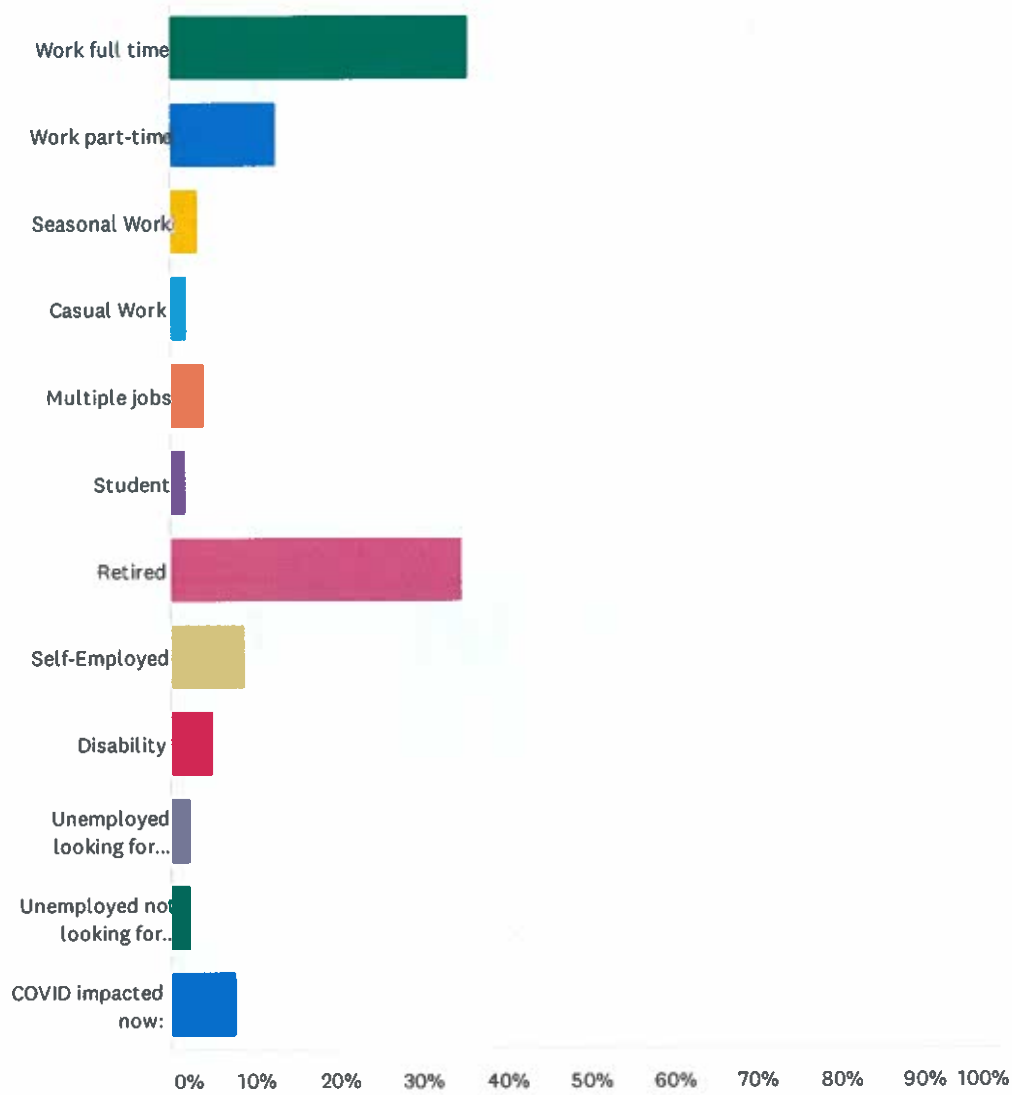

Almaguin Community Safety and Well Being Plan Survey 2020

| ANSWER CHOICES                  | RESPONSES |     |
|---------------------------------|-----------|-----|
| Work full time                  | 35.83%    | 129 |
| Work part-time                  | 12.78%    | 46  |
| Seasonal Work                   | 3.33%     | 12  |
| Casual Work                     | 1.94%     | 7   |
| Multiple jobs                   | 3.89%     | 14  |
| Student                         | 1.67%     | 6   |
| Retired                         | 35.00%    | 126 |
| Self-Employed                   | 8.89%     | 32  |
| Disability                      | 5.00%     | 18  |
| Unemployed looking for work     | 2.22%     | 8   |
| Unemployed not looking for work | 2.22%     | 8   |
| COVID impacted now:             | 7.78%     | 28  |
| Total Respondents: 360          |           |     |

Almaguin Community Safety and Well Being Plan Survey 2020

| #  | COVID IMPACTED NOW:                                                                                   | DATE               |
|----|-------------------------------------------------------------------------------------------------------|--------------------|
| 1  | On CERB                                                                                               | 6/4/2020 11:04 AM  |
| 2  | Preexisting lung and breathing medical issues.                                                        | 6/1/2020 5:37 AM   |
| 3  | Working from home                                                                                     | 5/26/2020 5:02 PM  |
| 4  | Full Time at one job, Work from home at the other                                                     | 5/26/2020 12:08 PM |
| 5  | Will be taking leave at wnd of week                                                                   | 5/26/2020 11:56 AM |
| 6  | tempoary layoff                                                                                       | 5/25/2020 9:12 PM  |
| 7  | High risk                                                                                             | 5/25/2020 10:41 AM |
| 8  | Suspended due to COVID                                                                                | 5/16/2020 6:58 PM  |
| 9  | Took leave                                                                                            | 5/16/2020 5:33 PM  |
| 10 | work possibly not opening this year                                                                   | 5/16/2020 5:27 PM  |
| 11 | I am a homemaker that was not an option in the list                                                   | 5/15/2020 1:09 PM  |
| 12 | closed                                                                                                | 5/15/2020 12:23 PM |
| 13 | Dental hygienist so laid off until further notice                                                     | 5/15/2020 1:40 AM  |
| 14 | Need to stay home with kids                                                                           | 5/14/2020 11:25 AM |
| 15 | Not working                                                                                           | 5/14/2020 10:52 AM |
| 16 | no income                                                                                             | 5/13/2020 6:47 PM  |
| 17 | ?                                                                                                     | 5/13/2020 1:05 PM  |
| 18 | Bumped up to full time                                                                                | 5/13/2020 9:14 AM  |
| 19 | Laid off                                                                                              | 5/12/2020 3:51 PM  |
| 20 | volunteer work changed                                                                                | 5/12/2020 2:12 PM  |
| 21 | On maternity leave/not sure of return to work now                                                     | 5/11/2020 11:10 PM |
| 22 | Unemployment                                                                                          | 5/11/2020 9:20 PM  |
| 23 | Maternity leave                                                                                       | 5/11/2020 5:33 PM  |
| 24 | I worked full time until the end of March, at which point I was temporarily laid off due to Covid-19. | 5/11/2020 4:46 PM  |
| 25 | no support                                                                                            | 5/11/2020 4:15 PM  |
| 26 | I have an immunocompromised child                                                                     | 5/11/2020 4:15 PM  |
| 27 | Not working                                                                                           | 5/11/2020 3:52 PM  |
| 28 | Not working at present                                                                                | 5/11/2020 3:35 PM  |



Q28 I feel as though my job/work is stable and reliable.

Answered: 318 Skipped: 127

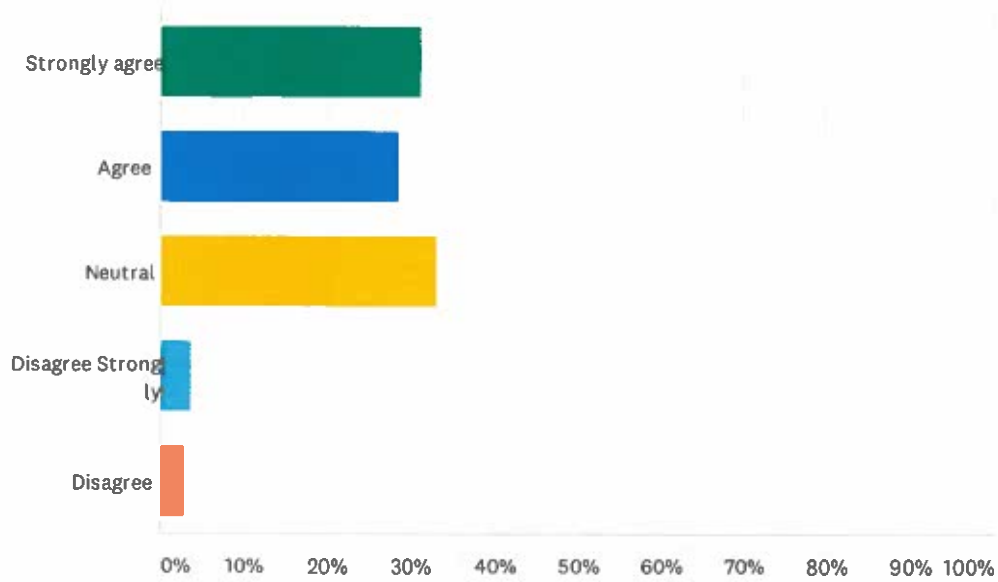

| ANSWER CHOICES    | RESPONSES |            |
|-------------------|-----------|------------|
| Strongly agree    | 31.45%    | 100        |
| Agree             | 28.62%    | 91         |
| Neutral           | 33.33%    | 106        |
| Disagree Strongly | 3.77%     | 12         |
| Disagree          | 2.83%     | 9          |
| <b>TOTAL</b>      |           | <b>318</b> |

### Q29 If you currently are, or ever been unemployed in your community, what factors prevented you from finding a job?

Answered: 230 Skipped: 215

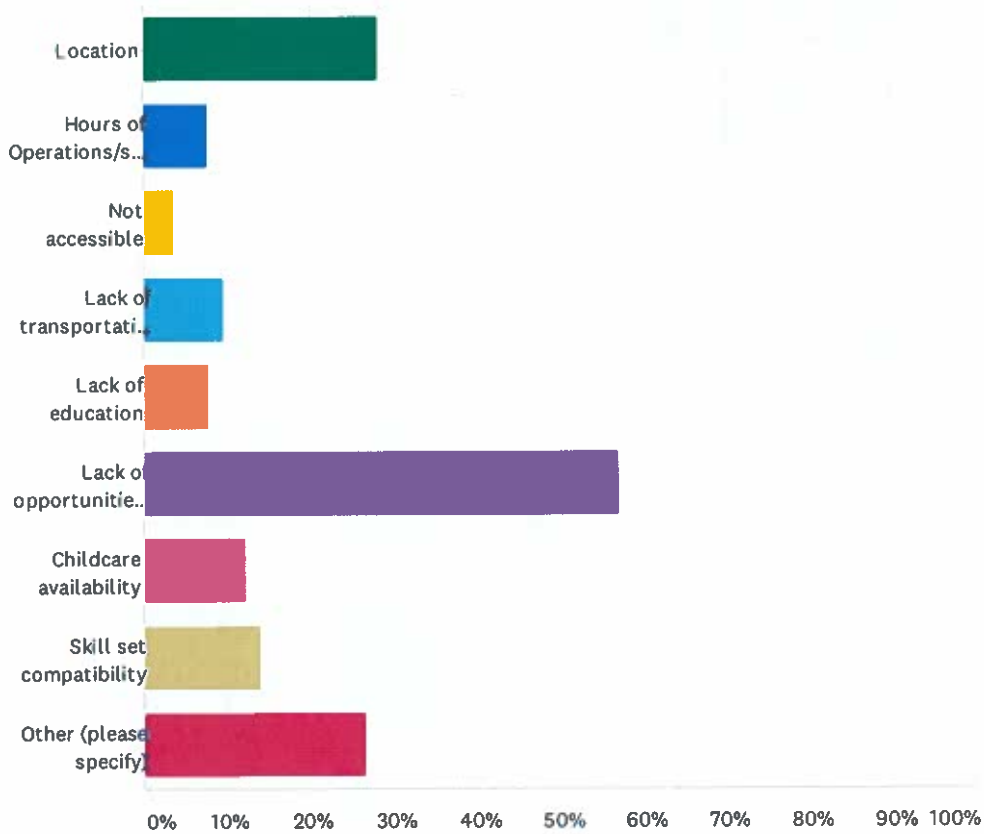

| ANSWER CHOICES                          | RESPONSES |     |
|-----------------------------------------|-----------|-----|
| Location                                | 28.26%    | 65  |
| Hours of Operations/shift               | 7.83%     | 18  |
| Not accessible                          | 3.48%     | 8   |
| Lack of transportation to job           | 9.57%     | 22  |
| Lack of education                       | 7.83%     | 18  |
| Lack of opportunities in your community | 56.96%    | 131 |
| Childcare availability                  | 12.17%    | 28  |
| Skill set compatibility                 | 13.91%    | 32  |
| Other (please specify)                  | 26.52%    | 61  |
| Total Respondents: 230                  |           |     |

Almaguin Community Safety and Well Being Plan Survey 2020

| #  | OTHER (PLEASE SPECIFY)                                                                                                                      | DATE               |
|----|---------------------------------------------------------------------------------------------------------------------------------------------|--------------------|
| 1  | Reliable and high speed Internet connection                                                                                                 | 6/7/2020 10:37 AM  |
| 2  | None                                                                                                                                        | 6/6/2020 10:36 PM  |
| 3  | None                                                                                                                                        | 6/6/2020 5:29 PM   |
| 4  | Poor health                                                                                                                                 | 6/3/2020 1:04 AM   |
| 5  | N/A                                                                                                                                         | 5/29/2020 9:10 AM  |
| 6  | Never been unemployed                                                                                                                       | 5/28/2020 8:51 PM  |
| 7  | N/a                                                                                                                                         | 5/28/2020 9:11 AM  |
| 8  | Not affected by this                                                                                                                        | 5/27/2020 9:04 PM  |
| 9  | Low pay for same job half hour away                                                                                                         | 5/27/2020 8:42 PM  |
| 10 | Always had a job                                                                                                                            | 5/27/2020 6:28 PM  |
| 11 | none                                                                                                                                        | 5/26/2020 10:45 PM |
| 12 | Not personally, but I sense a "who you know" is very prevalent.                                                                             | 5/26/2020 2:19 PM  |
| 13 | Retired                                                                                                                                     | 5/26/2020 11:22 AM |
| 14 | Retired                                                                                                                                     | 5/26/2020 10:44 AM |
| 15 | N/A                                                                                                                                         | 5/26/2020 7:45 AM  |
| 16 | before I became a stay at home mother, I travelled outside of the community for work, because there is a lack of jobs available in the area | 5/26/2020 7:33 AM  |
| 17 | Non of the above                                                                                                                            | 5/25/2020 10:55 PM |
| 18 | Lack of incentive/motivation                                                                                                                | 5/25/2020 7:22 PM  |
| 19 | retired                                                                                                                                     | 5/25/2020 5:16 PM  |
| 20 | neither apply                                                                                                                               | 5/25/2020 11:19 AM |
| 21 | Quality of living is important, good, decent paying jobs are important.                                                                     | 5/25/2020 10:06 AM |
| 22 | not applicable                                                                                                                              | 5/22/2020 6:02 PM  |
| 23 | Looking for younger people                                                                                                                  | 5/21/2020 1:57 PM  |
| 24 | Have always been employed in this community.                                                                                                | 5/19/2020 6:45 PM  |
| 25 | i have never been unemployed                                                                                                                | 5/19/2020 4:08 PM  |
| 26 | Does not apply to us                                                                                                                        | 5/19/2020 11:06 AM |
| 27 | No                                                                                                                                          | 5/18/2020 10:31 AM |
| 28 | physical disability                                                                                                                         | 5/18/2020 12:23 AM |
| 29 | Retired                                                                                                                                     | 5/17/2020 7:25 PM  |
| 30 | none                                                                                                                                        | 5/17/2020 3:22 PM  |
| 31 | Never been unemployed                                                                                                                       | 5/17/2020 8:59 AM  |
| 32 | N/A                                                                                                                                         | 5/16/2020 6:58 PM  |
| 33 | NA                                                                                                                                          | 5/16/2020 2:58 PM  |
| 34 | covid 19                                                                                                                                    | 5/15/2020 12:23 PM |
| 35 | Retired                                                                                                                                     | 5/15/2020 8:16 AM  |
| 36 | Not applicable                                                                                                                              | 5/15/2020 1:40 AM  |
| 37 | Physical disabilities, and lack of health care follow up to be well                                                                         | 5/14/2020 8:05 PM  |

Almaguin Community Safety and Well Being Plan Survey 2020

|    |                                                                                                                                                                                                                                                                                                                                                                                          |                    |
|----|------------------------------------------------------------------------------------------------------------------------------------------------------------------------------------------------------------------------------------------------------------------------------------------------------------------------------------------------------------------------------------------|--------------------|
| 38 | never unemployed.                                                                                                                                                                                                                                                                                                                                                                        | 5/14/2020 7:03 PM  |
| 39 | never been unemployed                                                                                                                                                                                                                                                                                                                                                                    | 5/14/2020 11:52 AM |
| 40 | Covid                                                                                                                                                                                                                                                                                                                                                                                    | 5/14/2020 10:52 AM |
| 41 | I haven't been unemployed while living here, but I was trapped in a job with a terrible supervisor that I needed to get away from for longer than I should have been because I couldn't find anything comparable in this area. I now work from home for a Toronto company that requires me to travel to Toronto twice per month for 3-4 days at a time. Not ideal but it pays the bills. | 5/13/2020 8:43 PM  |
| 42 | retired                                                                                                                                                                                                                                                                                                                                                                                  | 5/13/2020 7:29 PM  |
| 43 | Never been unemployed                                                                                                                                                                                                                                                                                                                                                                    | 5/13/2020 6:43 PM  |
| 44 | Health                                                                                                                                                                                                                                                                                                                                                                                   | 5/13/2020 5:49 PM  |
| 45 | i am employed                                                                                                                                                                                                                                                                                                                                                                            | 5/13/2020 4:14 PM  |
| 46 | N/A                                                                                                                                                                                                                                                                                                                                                                                      | 5/13/2020 10:20 AM |
| 47 | n/a                                                                                                                                                                                                                                                                                                                                                                                      | 5/13/2020 9:03 AM  |
| 48 | none of above                                                                                                                                                                                                                                                                                                                                                                            | 5/12/2020 10:00 PM |
| 49 | Retired                                                                                                                                                                                                                                                                                                                                                                                  | 5/12/2020 6:28 PM  |
| 50 | None                                                                                                                                                                                                                                                                                                                                                                                     | 5/12/2020 2:07 PM  |
| 51 | Not applicable                                                                                                                                                                                                                                                                                                                                                                           | 5/12/2020 1:08 PM  |
| 52 | I was always employed and am now retired.                                                                                                                                                                                                                                                                                                                                                | 5/12/2020 1:02 PM  |
| 53 | Does not apply                                                                                                                                                                                                                                                                                                                                                                           | 5/12/2020 12:46 PM |
| 54 | Does not apply.                                                                                                                                                                                                                                                                                                                                                                          | 5/12/2020 11:43 AM |
| 55 | Racial discrimination                                                                                                                                                                                                                                                                                                                                                                    | 5/12/2020 11:21 AM |
| 56 | Always been employed                                                                                                                                                                                                                                                                                                                                                                     | 5/12/2020 9:46 AM  |
| 57 | Lack of jobs where advancement is available                                                                                                                                                                                                                                                                                                                                              | 5/11/2020 11:10 PM |
| 58 | always had job                                                                                                                                                                                                                                                                                                                                                                           | 5/11/2020 5:06 PM  |
| 59 | Not applicable                                                                                                                                                                                                                                                                                                                                                                           | 5/11/2020 5:04 PM  |
| 60 | I have been lucky to always have work. And look forward to going back as soon as Covid-19 is under control.                                                                                                                                                                                                                                                                              | 5/11/2020 4:46 PM  |
| 61 | have no reason on why I can not find work locally                                                                                                                                                                                                                                                                                                                                        | 5/11/2020 3:48 PM  |

### Q30 Total income annually for your household

Answered: 337 Skipped: 108

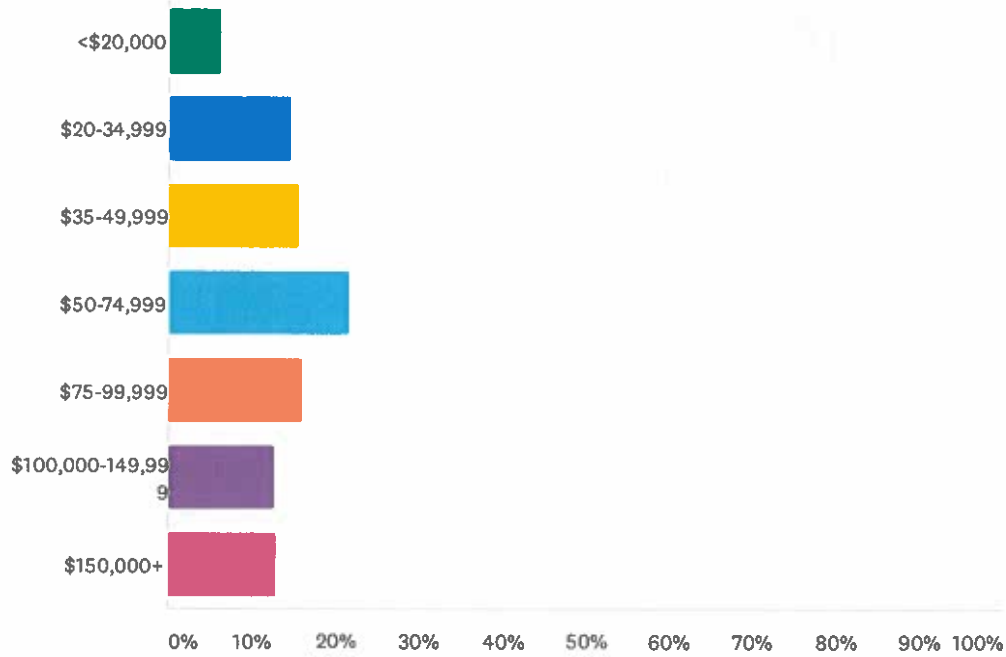

| ANSWER CHOICES    | RESPONSES |            |
|-------------------|-----------|------------|
| <\$20,000         | 6.23%     | 21         |
| \$20-34,999       | 14.54%    | 49         |
| \$35-49,999       | 15.73%    | 53         |
| \$50-74,999       | 21.66%    | 73         |
| \$75-99,999       | 16.02%    | 54         |
| \$100,000-149,999 | 12.76%    | 43         |
| \$150,000+        | 13.06%    | 44         |
| <b>TOTAL</b>      |           | <b>337</b> |

### Q31 Overall, how do you feel about your personal finances?

Answered: 360 Skipped: 85

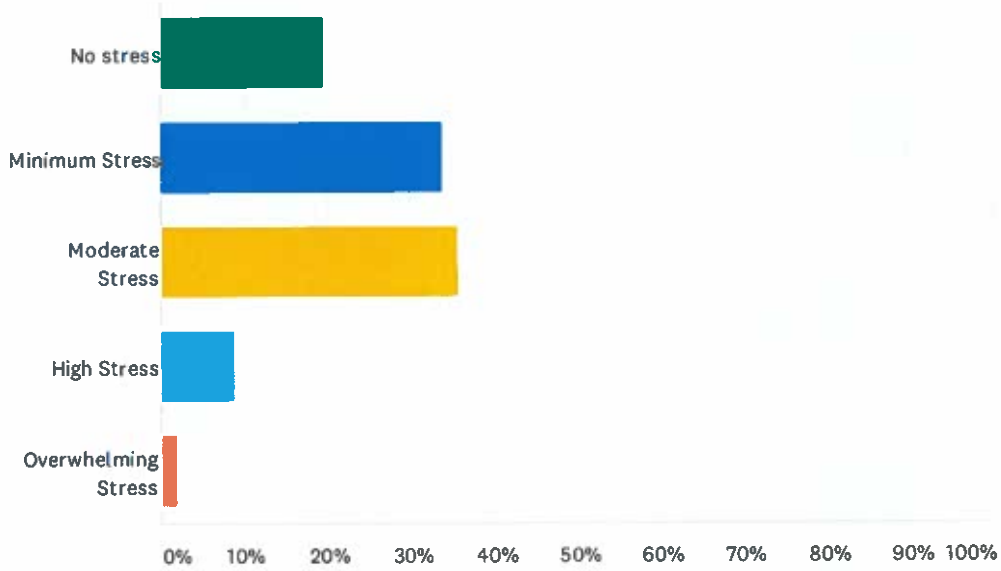

| ANSWER CHOICES      | RESPONSES |            |
|---------------------|-----------|------------|
| No stress           | 19.44%    | 70         |
| Minimum Stress      | 33.89%    | 122        |
| Moderate Stress     | 35.83%    | 129        |
| High Stress         | 8.89%     | 32         |
| Overwhelming Stress | 1.94%     | 7          |
| <b>TOTAL</b>        |           | <b>360</b> |

**Q32 What are your suggestions for improving living standards in your community?**

Answered: 194 Skipped: 251

## Almaguin Community Safety and Well Being Plan Survey 2020

| #  | RESPONSES                                                                                                                                                                                                         | DATE               |
|----|-------------------------------------------------------------------------------------------------------------------------------------------------------------------------------------------------------------------|--------------------|
| 1  | Reliable and high speed internet connection                                                                                                                                                                       | 6/7/2020 10:37 AM  |
| 2  | We like the Sand Lake area and hope the current level of activity on the lake remains the same. Certainly no more.                                                                                                | 6/6/2020 10:28 AM  |
| 3  | Improved downtown- more shops for tourists. More sit-down restaurants.                                                                                                                                            | 6/5/2020 3:30 PM   |
| 4  | Bringing permanent and seasonal residents together to form a common bond.                                                                                                                                         | 6/4/2020 11:58 AM  |
| 5  | Maintain our road (West Bay Rd S) in the winter. This would make the year round residents on this Road safer.                                                                                                     | 6/4/2020 11:04 AM  |
| 6  | More community events during winter, like a winter parade through town                                                                                                                                            | 6/3/2020 3:55 PM   |
| 7  | Further efforts to promote the small businesses and efforts to improve internet access.                                                                                                                           | 6/3/2020 2:05 PM   |
| 8  | Encouraging more physical activity, events for whole community                                                                                                                                                    | 6/2/2020 11:14 PM  |
| 9  | jobs brought to the area. affordable housing                                                                                                                                                                      | 5/29/2020 5:45 PM  |
| 10 | Better local recreation; in-town doctor or clinic; better local kids' programming; economic development - especially hospitality.                                                                                 | 5/29/2020 9:10 AM  |
| 11 | More affordable housing for seniors and less fortunate                                                                                                                                                            | 5/28/2020 8:51 PM  |
| 12 | we need more doctors                                                                                                                                                                                              | 5/28/2020 12:47 PM |
| 13 | Keeping taxes at a reasonable rate of increase without severe reduction of services.                                                                                                                              | 5/28/2020 9:11 AM  |
| 14 | Reduce property tax rates, and provide incentives for business / young people to come back to small towns                                                                                                         | 5/28/2020 6:45 AM  |
| 15 | Creating more jobs                                                                                                                                                                                                | 5/27/2020 10:39 PM |
| 16 | NA                                                                                                                                                                                                                | 5/27/2020 9:04 PM  |
| 17 | Family doctor !!!!!!!!!!!!! Lower tax's Actually get something out of how much we pay !!!!!                                                                                                                       | 5/27/2020 8:42 PM  |
| 18 | Focus on full time residency. Too much tourism and cottage build up. Environmental stress in green spaces. Unclean water ways                                                                                     | 5/27/2020 6:44 PM  |
| 19 | Better paying jobs . Attract more work                                                                                                                                                                            | 5/27/2020 6:30 PM  |
| 20 | Caring about our problems and acting on them!                                                                                                                                                                     | 5/27/2020 6:28 PM  |
| 21 | Get a doctor would be the best start and go from there                                                                                                                                                            | 5/27/2020 4:32 PM  |
| 22 | More inclusion for ALL members of the community                                                                                                                                                                   | 5/27/2020 10:23 AM |
| 23 | more rental property required                                                                                                                                                                                     | 5/26/2020 10:45 PM |
| 24 | I would like to see more community events that encourage social activities                                                                                                                                        | 5/26/2020 5:37 PM  |
| 25 | More jobs. Keep property tax low.                                                                                                                                                                                 | 5/26/2020 5:04 PM  |
| 26 | more restaurants                                                                                                                                                                                                  | 5/26/2020 4:03 PM  |
| 27 | Adequate medical supports                                                                                                                                                                                         | 5/26/2020 3:12 PM  |
| 28 | Investing in property clean-up near downtown Improving communication with the council<br>Diversity on the council A business / infrastructure investment initiative Businesses and council supporting one another | 5/26/2020 2:19 PM  |
| 29 | Get us a doctor, please!                                                                                                                                                                                          | 5/26/2020 2:16 PM  |
| 30 | 15.00 min. wage                                                                                                                                                                                                   | 5/26/2020 1:01 PM  |
| 31 | Maybe having more community involvement                                                                                                                                                                           | 5/26/2020 11:56 AM |
| 32 | Right now , during the cover 19 crisis I am very impressed with our local businesses and our mayor . I am concerned about the going forward with the local rodeo at this time . I wish that the                   | 5/26/2020 11:22 AM |



## Almaguin Community Safety and Well Being Plan Survey 2020

|    |                                                                                                                                                                                                                                                                                                                                                                                                                                                                                                                                                                                                                                                                                                                                                                                                                                                        |                    |
|----|--------------------------------------------------------------------------------------------------------------------------------------------------------------------------------------------------------------------------------------------------------------------------------------------------------------------------------------------------------------------------------------------------------------------------------------------------------------------------------------------------------------------------------------------------------------------------------------------------------------------------------------------------------------------------------------------------------------------------------------------------------------------------------------------------------------------------------------------------------|--------------------|
|    | people who put it on would keep the locals informed of their plans and responsibly whose to cancel                                                                                                                                                                                                                                                                                                                                                                                                                                                                                                                                                                                                                                                                                                                                                     |                    |
| 33 | Having enough family doctors or nurse practitioners who can operate independently.                                                                                                                                                                                                                                                                                                                                                                                                                                                                                                                                                                                                                                                                                                                                                                     | 5/26/2020 11:19 AM |
| 34 | Recruiting more businesses to area                                                                                                                                                                                                                                                                                                                                                                                                                                                                                                                                                                                                                                                                                                                                                                                                                     | 5/26/2020 10:44 AM |
| 35 | More job opportunities. More medical personnel More activities for young people                                                                                                                                                                                                                                                                                                                                                                                                                                                                                                                                                                                                                                                                                                                                                                        | 5/26/2020 10:03 AM |
| 36 | Improving some infrastructure (specifically the public dock/boat launch in Burks Falls) and building a recreation facility with a pool to provide more extracurricular activities in the community                                                                                                                                                                                                                                                                                                                                                                                                                                                                                                                                                                                                                                                     | 5/26/2020 9:50 AM  |
| 37 | We pay high rent with a landlord that doesn't worry about getting things done very quickly if at all. We do everything ourselves.                                                                                                                                                                                                                                                                                                                                                                                                                                                                                                                                                                                                                                                                                                                      | 5/26/2020 8:53 AM  |
| 38 | Not my place. It is the decision of the Minister of Municipal Affairs. A review has been conducted and a report has been filed and remains confidential. I assume the Minister will make the best decisions as he himself is the author and drafter of the best by-laws in the Province and all in accordance with the Municipal Act. Each employee of a municipality MUST meet the academic requirements and must achieve the accreditation through provincial examinations to be in a position of extreme privacy with respect to the information of taxpayers. The Code of Conduct needs to be ENFORCED and a great deal of integrity and transparency and openness needs to be applied in every aspect of local municipalities' governance. These individuals work FOR us; this is a concept that seems to have become confused with Dictatorship. | 5/26/2020 7:45 AM  |
| 39 | bring small businesses to the downtown core, fill up the very empty store front, maybe the government can offer incentives, which will create jobs, and building the community, more housing created.                                                                                                                                                                                                                                                                                                                                                                                                                                                                                                                                                                                                                                                  | 5/26/2020 7:33 AM  |
| 40 | Have geared to income apartments and allow smaller homes, like tiny homes.                                                                                                                                                                                                                                                                                                                                                                                                                                                                                                                                                                                                                                                                                                                                                                             | 5/26/2020 3:12 AM  |
| 41 | More support for food bank, re-training services. Free daycare for those retraining and visiting food bank                                                                                                                                                                                                                                                                                                                                                                                                                                                                                                                                                                                                                                                                                                                                             | 5/25/2020 10:55 PM |
| 42 | Better job opportunities                                                                                                                                                                                                                                                                                                                                                                                                                                                                                                                                                                                                                                                                                                                                                                                                                               | 5/25/2020 10:17 PM |
| 43 | Economic growth is the best way to raise living standards                                                                                                                                                                                                                                                                                                                                                                                                                                                                                                                                                                                                                                                                                                                                                                                              | 5/25/2020 7:21 PM  |
| 44 | above average affordable restaurant small hardware store improve the look of our village ..eg more gardens, resident clean up programs / enforced bylaws more benches ,gardens etc in beautiful tom thomson park                                                                                                                                                                                                                                                                                                                                                                                                                                                                                                                                                                                                                                       | 5/25/2020 5:16 PM  |
| 45 | We need programs for all age groups. We only have the arena and hockey and figure skating doesn't cut it for year round and kids baseball and soccer is ruined by bug season                                                                                                                                                                                                                                                                                                                                                                                                                                                                                                                                                                                                                                                                           | 5/25/2020 10:41 AM |
| 46 | Fully review my Minister Clark; he knows best.                                                                                                                                                                                                                                                                                                                                                                                                                                                                                                                                                                                                                                                                                                                                                                                                         | 5/25/2020 10:20 AM |
| 47 | Increase monthly social assistance benefits, increase access to affordable, safe housing, access to affordable, regular transportation, lower internet costs & increase access                                                                                                                                                                                                                                                                                                                                                                                                                                                                                                                                                                                                                                                                         | 5/25/2020 10:18 AM |
| 48 | We need employers that value their employees and pay them fairly, everyone deserves a quality of life. We need employers that will train/apprentice their staff. We NEED affordable housing.                                                                                                                                                                                                                                                                                                                                                                                                                                                                                                                                                                                                                                                           | 5/25/2020 10:06 AM |
| 49 | Municipal investment in infrastructure similar to South River building the Highland Centre                                                                                                                                                                                                                                                                                                                                                                                                                                                                                                                                                                                                                                                                                                                                                             | 5/25/2020 8:18 AM  |
| 50 | More affordable housing support for seniors                                                                                                                                                                                                                                                                                                                                                                                                                                                                                                                                                                                                                                                                                                                                                                                                            | 5/20/2020 11:18 AM |
| 51 | more seniors programs, tai chi, yoga, etc..                                                                                                                                                                                                                                                                                                                                                                                                                                                                                                                                                                                                                                                                                                                                                                                                            | 5/19/2020 7:39 PM  |
| 52 | Better paying jobs in our area.                                                                                                                                                                                                                                                                                                                                                                                                                                                                                                                                                                                                                                                                                                                                                                                                                        | 5/19/2020 6:45 PM  |
| 53 | we need to attract and support more businesses and industry, and we are an aging community (as is the rest of Almaguin) that needs to attract more young couples to our community                                                                                                                                                                                                                                                                                                                                                                                                                                                                                                                                                                                                                                                                      | 5/19/2020 4:08 PM  |
| 54 | more affordable homes                                                                                                                                                                                                                                                                                                                                                                                                                                                                                                                                                                                                                                                                                                                                                                                                                                  | 5/19/2020 12:25 PM |
| 55 | Clean up properties                                                                                                                                                                                                                                                                                                                                                                                                                                                                                                                                                                                                                                                                                                                                                                                                                                    | 5/19/2020 11:06 AM |
| 56 | More community events                                                                                                                                                                                                                                                                                                                                                                                                                                                                                                                                                                                                                                                                                                                                                                                                                                  | 5/19/2020 7:47 AM  |

## Almaguin Community Safety and Well Being Plan Survey 2020

|    |                                                                                                                                                                                                                                                         |                    |
|----|---------------------------------------------------------------------------------------------------------------------------------------------------------------------------------------------------------------------------------------------------------|--------------------|
| 57 | High speed internet.                                                                                                                                                                                                                                    | 5/18/2020 11:50 PM |
| 58 | I think living standards are acceptable. Perhaps more opportunities for physical exercise closer to where we live.                                                                                                                                      | 5/18/2020 7:34 PM  |
| 59 | None                                                                                                                                                                                                                                                    | 5/18/2020 10:31 AM |
| 60 | Jobs /community pride and beautification /post office / bank restaurant /activities in community centers /                                                                                                                                              | 5/18/2020 9:25 AM  |
| 61 | Attract commercial/industrial employers                                                                                                                                                                                                                 | 5/17/2020 7:25 PM  |
| 62 | employment                                                                                                                                                                                                                                              | 5/17/2020 3:18 PM  |
| 63 | We need well paying jobs in this area. Not North bay and Huntsville. Affordable grocery stores. Night classes                                                                                                                                           | 5/17/2020 2:10 PM  |
| 64 | Community safety is most important. Police presence is important.                                                                                                                                                                                       | 5/17/2020 8:59 AM  |
| 65 | monitor boat traffic on the water ways more activities to participate in physical fitness                                                                                                                                                               | 5/17/2020 8:19 AM  |
| 66 | Services                                                                                                                                                                                                                                                | 5/16/2020 5:33 PM  |
| 67 | raise minimum wage                                                                                                                                                                                                                                      | 5/16/2020 5:27 PM  |
| 68 | Perhaps more housing and some form of transit.                                                                                                                                                                                                          | 5/16/2020 2:58 PM  |
| 69 | More available well paying work for those that want it.                                                                                                                                                                                                 | 5/16/2020 12:39 PM |
| 70 | Public transportation (and much better roads!), more support for Fire Department, bring in some sort of senior housing or LTC home, better arena/community center and access to an emergency health care closer than North Bay or Huntsville hospitals. | 5/16/2020 8:49 AM  |
| 71 | I have no suggestions, however, remain hopeful for the presence of another doctor to fill the void left by departure of my previous family physician                                                                                                    | 5/16/2020 6:26 AM  |
| 72 | A harvest share program or more information about one if it all ready exists                                                                                                                                                                            | 5/15/2020 11:21 PM |
| 73 | More doctors. Transportation for those who cannot drive.Example to North Bay or Huntsville.                                                                                                                                                             | 5/15/2020 7:06 PM  |
| 74 | Need to find ways to support the economic rejuvenation of Burks Falls downtown businesses.                                                                                                                                                              | 5/15/2020 6:55 PM  |
| 75 | Get rid of the high density low rental housing! Stop building more!                                                                                                                                                                                     | 5/15/2020 6:17 PM  |
| 76 | Lower the taxes                                                                                                                                                                                                                                         | 5/15/2020 1:09 PM  |
| 77 | Hi speed internet, Broadband                                                                                                                                                                                                                            | 5/15/2020 12:23 PM |
| 78 | cost of living in a small town is very high, for single person with children. taxes are to high, but lack of housing that is affordable                                                                                                                 | 5/15/2020 12:15 PM |
| 79 | More industry                                                                                                                                                                                                                                           | 5/15/2020 11:18 AM |
| 80 | more industry to provide employment                                                                                                                                                                                                                     | 5/15/2020 10:53 AM |
| 81 | more services, more health care                                                                                                                                                                                                                         | 5/15/2020 10:34 AM |
| 82 | Accountability, transparency and responsibility by elected officials, police and government employees.                                                                                                                                                  | 5/15/2020 8:16 AM  |
| 83 | More community events for all ages, more social interactions. More doctors in area                                                                                                                                                                      | 5/15/2020 1:40 AM  |
| 84 | More employment opportunities, more housing such as apartments, not just for seniors. My stepsons both are adults and need affordable apartments or will move out of the community.                                                                     | 5/14/2020 10:58 PM |
| 85 | GET A DR. THE MOST PRESSING ISSUE ID LACK OF XOMMUNITY HEALTHCARE. WHEN THERE WAS WHEN EVERYONE MOVED HERE. It 8s actually Embarassing this has happened here, and continues.                                                                           | 5/14/2020 8:05 PM  |
| 86 | Education. Available courses/seminars for consumers to learn about buying/building/education.                                                                                                                                                           | 5/14/2020 7:03 PM  |
| 87 | More affordable housing for rent and seniors                                                                                                                                                                                                            | 5/14/2020 12:05 PM |
| 88 | none                                                                                                                                                                                                                                                    | 5/14/2020 11:52 AM |

## Almaguin Community Safety and Well Being Plan Survey 2020

|     |                                                                                                                                                                                                                                                                   |                    |
|-----|-------------------------------------------------------------------------------------------------------------------------------------------------------------------------------------------------------------------------------------------------------------------|--------------------|
| 89  | Don't know                                                                                                                                                                                                                                                        | 5/14/2020 11:25 AM |
| 90  | Higher hourly pay more opportunities                                                                                                                                                                                                                              | 5/14/2020 10:52 AM |
| 91  | Improve food bank                                                                                                                                                                                                                                                 | 5/14/2020 9:12 AM  |
| 92  | more affordable housing                                                                                                                                                                                                                                           | 5/14/2020 9:06 AM  |
| 93  | good paying jobs for young people                                                                                                                                                                                                                                 | 5/14/2020 7:36 AM  |
| 94  | Unsure                                                                                                                                                                                                                                                            | 5/14/2020 7:26 AM  |
| 95  | ?                                                                                                                                                                                                                                                                 | 5/14/2020 1:12 AM  |
| 96  | We need more jobs for local people who may not be able to travel for a job. Stop raising our ridiculous water prices when we can't even drink it - paying for town water and then have to buy bottled water to consume.                                           | 5/13/2020 10:26 PM |
| 97  | N/A                                                                                                                                                                                                                                                               | 5/13/2020 9:54 PM  |
| 98  | High speed internet at an affordable rate                                                                                                                                                                                                                         | 5/13/2020 9:07 PM  |
| 99  | Improved internet. More businesses and development. Emergerncy responce centre.                                                                                                                                                                                   | 5/13/2020 9:03 PM  |
| 100 | More jobs                                                                                                                                                                                                                                                         | 5/13/2020 8:47 PM  |
| 101 | I don't know where to begin. It is a complex, multi-faceted issue and the challenges people face are not uniform across the region. I think if you can create good jobs for people, this eventually gives them the ability to improve their own living standards. | 5/13/2020 8:43 PM  |
| 102 | Swimming pool lighted walking paths dog park                                                                                                                                                                                                                      | 5/13/2020 7:52 PM  |
| 103 | Higher paying jobs                                                                                                                                                                                                                                                | 5/13/2020 7:35 PM  |
| 104 | Maintaining a list of people who are willing to do odd jobs for seniors, for example snow shoveling, yard work, handyman duties, etc. that are willing to work for minimum wage.                                                                                  | 5/13/2020 7:29 PM  |
| 105 | promote healthy lifestyles, including diet, exercise and smoking-cessation                                                                                                                                                                                        | 5/13/2020 6:47 PM  |
| 106 | More recreation, improves access to health care (medical and mental health), subsidized housing                                                                                                                                                                   | 5/13/2020 6:43 PM  |
| 107 | Affordable housing and care supports for seniors. Care supports that will allow peopke to better age in place at home                                                                                                                                             | 5/13/2020 6:23 PM  |
| 108 | Better infrastructure, to encourage more businesses and opportunities for employment.                                                                                                                                                                             | 5/13/2020 5:39 PM  |
| 109 | Get rid of those two bastards at Pool lake boat launch Lea and Brandt Cook !                                                                                                                                                                                      | 5/13/2020 4:12 PM  |
| 110 | sidewalks, street lights, industry is needed for jobs                                                                                                                                                                                                             | 5/13/2020 4:03 PM  |
| 111 | transportation barrier                                                                                                                                                                                                                                            | 5/13/2020 3:53 PM  |
| 112 | Housing, Hotels, Restaurants, Improved OPP relations with community's youth                                                                                                                                                                                       | 5/13/2020 3:16 PM  |
| 113 | More job availabilities                                                                                                                                                                                                                                           | 5/13/2020 1:05 PM  |
| 114 | Make more jobs available for people, open up the downtown.                                                                                                                                                                                                        | 5/13/2020 12:45 PM |
| 115 | Be more supportive and inclusive of the permanent year round residents. Put us and our needs first over that of seasonal visitors.                                                                                                                                | 5/13/2020 12:19 PM |
| 116 | I live in a small village and love it. It's friendly, caring and helpful for everyone. Life is good                                                                                                                                                               | 5/13/2020 11:46 AM |
| 117 | None                                                                                                                                                                                                                                                              | 5/13/2020 11:43 AM |
| 118 | Grocery store prices and gas stations are for cottage country living they are too much expensive to shop at regularly so many leave town to shop, if prices were affordable more money would be kept in the community.                                            | 5/13/2020 11:39 AM |
| 119 | Get a doctor would be a great start.                                                                                                                                                                                                                              | 5/13/2020 10:41 AM |
| 120 | Expect low income families to keep homes, rentals properties clean. If low income families                                                                                                                                                                        | 5/13/2020 10:20 AM |

## Almaguin Community Safety and Well Being Plan Survey 2020

receive money to stay low income, they will rarely change outlook

|     |                                                                                                                                                                                                                                                                                                                                                                                                                                                                                                                                                                                                                                      |                    |
|-----|--------------------------------------------------------------------------------------------------------------------------------------------------------------------------------------------------------------------------------------------------------------------------------------------------------------------------------------------------------------------------------------------------------------------------------------------------------------------------------------------------------------------------------------------------------------------------------------------------------------------------------------|--------------------|
| 121 | Less dependence on government systems and more work programs                                                                                                                                                                                                                                                                                                                                                                                                                                                                                                                                                                         | 5/13/2020 10:15 AM |
| 122 | We need to have a community based hub like Powassan does. It will encourage young families to move into our village. Seniors residences are needed to free up homes for young families to move into. So many of my friends are hanging onto homes, they no longer want to live in, because they do not want to leave Sundridge.                                                                                                                                                                                                                                                                                                      | 5/13/2020 9:58 AM  |
| 123 | More places to rent for young and seniors that are affordable                                                                                                                                                                                                                                                                                                                                                                                                                                                                                                                                                                        | 5/13/2020 9:38 AM  |
| 124 | More job programs within community. I struggle to find a part-time job as I appear over qualified for most roles and feel that I am overlooked because of this. Most non-part time jobs in the community are dominated by males.                                                                                                                                                                                                                                                                                                                                                                                                     | 5/13/2020 9:34 AM  |
| 125 | create more employment opportunities in the Almaguin Highlands area                                                                                                                                                                                                                                                                                                                                                                                                                                                                                                                                                                  | 5/13/2020 9:33 AM  |
| 126 | None                                                                                                                                                                                                                                                                                                                                                                                                                                                                                                                                                                                                                                 | 5/13/2020 8:29 AM  |
| 127 | Affordable housing. An actual job market. Assistance with transportation to areas with jobs.                                                                                                                                                                                                                                                                                                                                                                                                                                                                                                                                         | 5/13/2020 7:06 AM  |
| 128 | This town seems to discourage new businesses from opening up, The mayor dictates what he wants and the rest of council are like sheep                                                                                                                                                                                                                                                                                                                                                                                                                                                                                                | 5/13/2020 6:10 AM  |
| 129 | Need for low rental , lower costs of food or compatibility , need for transportation, garbage pickup in katrine , need for local clothing store . Cheaper rental space for businesses, A giant Tiger or something ? A dollar store ?                                                                                                                                                                                                                                                                                                                                                                                                 | 5/12/2020 10:59 PM |
| 130 | Get ALL localities to share for the benefit of all                                                                                                                                                                                                                                                                                                                                                                                                                                                                                                                                                                                   | 5/12/2020 10:00 PM |
| 131 | N/A                                                                                                                                                                                                                                                                                                                                                                                                                                                                                                                                                                                                                                  | 5/12/2020 9:31 PM  |
| 132 | locals need to care about the people who come north for half the year and support locals but make us feel unwelcome. I had was very angry and very disappointed over the covid response. I have supported Magnetawan for over 40 years/                                                                                                                                                                                                                                                                                                                                                                                              | 5/12/2020 9:29 PM  |
| 133 | Not sure                                                                                                                                                                                                                                                                                                                                                                                                                                                                                                                                                                                                                             | 5/12/2020 8:40 PM  |
| 134 | Do not allow dogs to run loss, it takes away the enjoyment of walking for seniors.                                                                                                                                                                                                                                                                                                                                                                                                                                                                                                                                                   | 5/12/2020 7:46 PM  |
| 135 | Get some businesses on the main street, it looks like a ghost town                                                                                                                                                                                                                                                                                                                                                                                                                                                                                                                                                                   | 5/12/2020 7:19 PM  |
| 136 | I can see more housing options becoming available, however, these are usually fixed income units. We need to grow our industry options to coax more young families and individuals to the area, to invest here.                                                                                                                                                                                                                                                                                                                                                                                                                      | 5/12/2020 3:33 PM  |
| 137 | None                                                                                                                                                                                                                                                                                                                                                                                                                                                                                                                                                                                                                                 | 5/12/2020 2:35 PM  |
| 138 | encourage local businesses and provide opportunities for youth employment                                                                                                                                                                                                                                                                                                                                                                                                                                                                                                                                                            | 5/12/2020 2:12 PM  |
| 139 | i do not know                                                                                                                                                                                                                                                                                                                                                                                                                                                                                                                                                                                                                        | 5/12/2020 2:07 PM  |
| 140 | The regulatory environment, for example, building codes, is an impediment to business development as well as residential development. The standards may be relevant in larger communities, but are burdensome and a real hindrance in a community the size of Magnetawan and the surrounding communities                                                                                                                                                                                                                                                                                                                             | 5/12/2020 2:07 PM  |
| 141 | Focus on job opportunities and affordable housing to bring young adults back to the community. If we lose them we lose our community, history, culture, everything.                                                                                                                                                                                                                                                                                                                                                                                                                                                                  | 5/12/2020 2:05 PM  |
| 142 | Not sure. Better health care.                                                                                                                                                                                                                                                                                                                                                                                                                                                                                                                                                                                                        | 5/12/2020 1:08 PM  |
| 143 | We need better access to local Health Care and it would be nice if those who worked here; especially in good paying jobs lived here so the area would benefit form their pay. For instance, at one time almost all the police officers and teachers lived in the area. This meant that they shopped here and were a big part of the community. Currently I believe two teachers at the local school (Land of Lakes) live in the area. This means they spend their salaries; which they earn here, somewhere else. The same goes for police officers. I believe only two or three of them live in the area ; - - none in Burk's Falls | 5/12/2020 1:02 PM  |
| 144 | Stop the petty double standards between what the local residents can do, versus seasonal taxpayers. There is definitely an "old boys club mentality", and if you are in that group, you are                                                                                                                                                                                                                                                                                                                                                                                                                                          | 5/12/2020 12:50 PM |

## Almaguin Community Safety and Well Being Plan Survey 2020

|     |                                                                                                                                                                                                                                                                                                                                                                                                                                                                                                                                                                                                                                       |                    |
|-----|---------------------------------------------------------------------------------------------------------------------------------------------------------------------------------------------------------------------------------------------------------------------------------------------------------------------------------------------------------------------------------------------------------------------------------------------------------------------------------------------------------------------------------------------------------------------------------------------------------------------------------------|--------------------|
|     | ok. If not, look out! Very crooked.                                                                                                                                                                                                                                                                                                                                                                                                                                                                                                                                                                                                   |                    |
| 145 | More opportunities for employment for younger people.                                                                                                                                                                                                                                                                                                                                                                                                                                                                                                                                                                                 | 5/12/2020 12:46 PM |
| 146 | Doctors office                                                                                                                                                                                                                                                                                                                                                                                                                                                                                                                                                                                                                        | 5/12/2020 12:45 PM |
| 147 | Complete review and overhaul of entire Municipal books, records, by-laws and operations. There is too much fraud, out-of-date, badly drafted by-laws and by-laws that conflict with upper tier legislation and laws. Single tier needs to be brought into compliance in every aspect of its operation or relieved of its administration and transferred or amalgamated. Each member of council including the "mayor" must be reorganized and must be orientated to handle the role of councillor or mayor with the level of expertise necessary and be on an equal level with those in the same capacity in all other municipalities. | 5/12/2020 11:43 AM |
| 148 | Creation of better paying employment                                                                                                                                                                                                                                                                                                                                                                                                                                                                                                                                                                                                  | 5/12/2020 11:21 AM |
| 149 | counselling, doctors, events                                                                                                                                                                                                                                                                                                                                                                                                                                                                                                                                                                                                          | 5/12/2020 11:16 AM |
| 150 | n/a                                                                                                                                                                                                                                                                                                                                                                                                                                                                                                                                                                                                                                   | 5/12/2020 10:21 AM |
| 151 | Starting in the schools and inspiring the next generation to work hard and have an internal locus of control (not be a victim).                                                                                                                                                                                                                                                                                                                                                                                                                                                                                                       | 5/12/2020 9:46 AM  |
| 152 | Dunno                                                                                                                                                                                                                                                                                                                                                                                                                                                                                                                                                                                                                                 | 5/12/2020 9:03 AM  |
| 153 | townships to stop nickle and diming, respect, and have a gym with equipment to keep physical strong as fitness classes are not always available                                                                                                                                                                                                                                                                                                                                                                                                                                                                                       | 5/11/2020 11:39 PM |
| 154 | Always more affordable housing                                                                                                                                                                                                                                                                                                                                                                                                                                                                                                                                                                                                        | 5/11/2020 11:10 PM |
| 155 | affordable houseing                                                                                                                                                                                                                                                                                                                                                                                                                                                                                                                                                                                                                   | 5/11/2020 10:33 PM |
| 156 | Better infrastructure. Bus to surrounding larger towns.                                                                                                                                                                                                                                                                                                                                                                                                                                                                                                                                                                               | 5/11/2020 10:31 PM |
| 157 | Better access to high-speed Internet. Jobs closer to home. More community involvement.                                                                                                                                                                                                                                                                                                                                                                                                                                                                                                                                                | 5/11/2020 10:12 PM |
| 158 | Affordable housing                                                                                                                                                                                                                                                                                                                                                                                                                                                                                                                                                                                                                    | 5/11/2020 9:50 PM  |
| 159 | Sidewalks, streetlights and ditches in the main part of town.                                                                                                                                                                                                                                                                                                                                                                                                                                                                                                                                                                         | 5/11/2020 9:37 PM  |
| 160 | Affordable housing Allow people to build, live in smaller sq foot dwellings. Reduce municipal minimum sq foot requirements                                                                                                                                                                                                                                                                                                                                                                                                                                                                                                            | 5/11/2020 9:20 PM  |
| 161 | walking and bike trails                                                                                                                                                                                                                                                                                                                                                                                                                                                                                                                                                                                                               | 5/11/2020 9:15 PM  |
| 162 | More events that bring people together.                                                                                                                                                                                                                                                                                                                                                                                                                                                                                                                                                                                               | 5/11/2020 9:11 PM  |
| 163 | transportation to work places more doctors here, not in Huntsville                                                                                                                                                                                                                                                                                                                                                                                                                                                                                                                                                                    | 5/11/2020 8:58 PM  |
| 164 | Enforce bylaws                                                                                                                                                                                                                                                                                                                                                                                                                                                                                                                                                                                                                        | 5/11/2020 8:42 PM  |
| 165 | Industry                                                                                                                                                                                                                                                                                                                                                                                                                                                                                                                                                                                                                              | 5/11/2020 8:40 PM  |
| 166 | More open stores                                                                                                                                                                                                                                                                                                                                                                                                                                                                                                                                                                                                                      | 5/11/2020 8:26 PM  |
| 167 | Hydro delivery fees, food cost                                                                                                                                                                                                                                                                                                                                                                                                                                                                                                                                                                                                        | 5/11/2020 7:56 PM  |
| 168 | I wish I had a suggestion.                                                                                                                                                                                                                                                                                                                                                                                                                                                                                                                                                                                                            | 5/11/2020 5:50 PM  |
| 169 | Low income seniors housing needed, recreation programs for individuals of all ages, access to social support groups                                                                                                                                                                                                                                                                                                                                                                                                                                                                                                                   | 5/11/2020 5:37 PM  |
| 170 | Lower taxes, more events                                                                                                                                                                                                                                                                                                                                                                                                                                                                                                                                                                                                              | 5/11/2020 5:33 PM  |
| 171 | Adult programs                                                                                                                                                                                                                                                                                                                                                                                                                                                                                                                                                                                                                        | 5/11/2020 5:24 PM  |
| 172 | Working together as a community to come up with solutions not just one to five people making choices                                                                                                                                                                                                                                                                                                                                                                                                                                                                                                                                  | 5/11/2020 5:15 PM  |
| 173 | Access to reasonable cost public transportation buses, cabs.                                                                                                                                                                                                                                                                                                                                                                                                                                                                                                                                                                          | 5/11/2020 5:12 PM  |
| 174 | More businesses                                                                                                                                                                                                                                                                                                                                                                                                                                                                                                                                                                                                                       | 5/11/2020 5:07 PM  |
| 175 | more low income housing...tiny house compound for affordable living                                                                                                                                                                                                                                                                                                                                                                                                                                                                                                                                                                   | 5/11/2020 5:06 PM  |

## Almaguin Community Safety and Well Being Plan Survey 2020

|     |                                                                                                                                                                                                                                                                                                                                       |                   |
|-----|---------------------------------------------------------------------------------------------------------------------------------------------------------------------------------------------------------------------------------------------------------------------------------------------------------------------------------------|-------------------|
| 176 | businesses need to be promoted to increase work available                                                                                                                                                                                                                                                                             | 5/11/2020 5:05 PM |
| 177 | .                                                                                                                                                                                                                                                                                                                                     | 5/11/2020 5:04 PM |
| 178 | Affordable rent                                                                                                                                                                                                                                                                                                                       | 5/11/2020 5:02 PM |
| 179 | improving library services, ie more art classes, etc.                                                                                                                                                                                                                                                                                 | 5/11/2020 4:53 PM |
| 180 | ,                                                                                                                                                                                                                                                                                                                                     | 5/11/2020 4:50 PM |
| 181 | Lower the cost of water and sewer. Water should be a basic right and to charge such high prices is absolutely unfair to those in our community who struggle to make ends meet.                                                                                                                                                        | 5/11/2020 4:46 PM |
| 182 | More opportunities                                                                                                                                                                                                                                                                                                                    | 5/11/2020 4:39 PM |
| 183 | Affordable housing-renting and buying Sidewalks that go all the way to the grocery store<br>Employment opportunities                                                                                                                                                                                                                  | 5/11/2020 4:37 PM |
| 184 | jobs                                                                                                                                                                                                                                                                                                                                  | 5/11/2020 4:15 PM |
| 185 | Viable economic stability. Factories, housing availability, shopping accessibility in downtown core, stability of a variety of shops to meet all of our needs without having to travel to larger centres                                                                                                                              | 5/11/2020 4:14 PM |
| 186 | More affordable housing                                                                                                                                                                                                                                                                                                               | 5/11/2020 4:13 PM |
| 187 | Clean up more than just the facade of the downtown buildings and actually start to enforce and follow-up with building standards and property standard complaints                                                                                                                                                                     | 5/11/2020 4:10 PM |
| 188 | Have more full time job opportunities. For a retirement community, why isn't there a retirement home or nursing home.                                                                                                                                                                                                                 | 5/11/2020 4:08 PM |
| 189 | I really don't know.                                                                                                                                                                                                                                                                                                                  | 5/11/2020 4:06 PM |
| 190 | More employment, economic development, more businesses. Access to nature and recreation                                                                                                                                                                                                                                               | 5/11/2020 3:52 PM |
| 191 | ability to find employment and rental housing                                                                                                                                                                                                                                                                                         | 5/11/2020 3:48 PM |
| 192 | Adding high speed internet to rural areas of Burk's Falls                                                                                                                                                                                                                                                                             | 5/11/2020 3:48 PM |
| 193 | Develop a plan to attract business to the downtown so there are more than 2 hardware stores, real estate offices, and a bank. Develop a grant to improve esthetics of downtown core. Empty waste containers when full. Repair sidewalks. Enforce property standards bylaw without a complaint received but by proactively patrolling. | 5/11/2020 3:40 PM |
| 194 | More affordable housing, more doctors                                                                                                                                                                                                                                                                                                 | 5/11/2020 3:35 PM |

**Q33 If your community, or an Almaguin regional program, were set up would you support/participate in any of the following to improve well-being for yourself or the community in general (select all that apply):**

Answered: 316 Skipped: 129

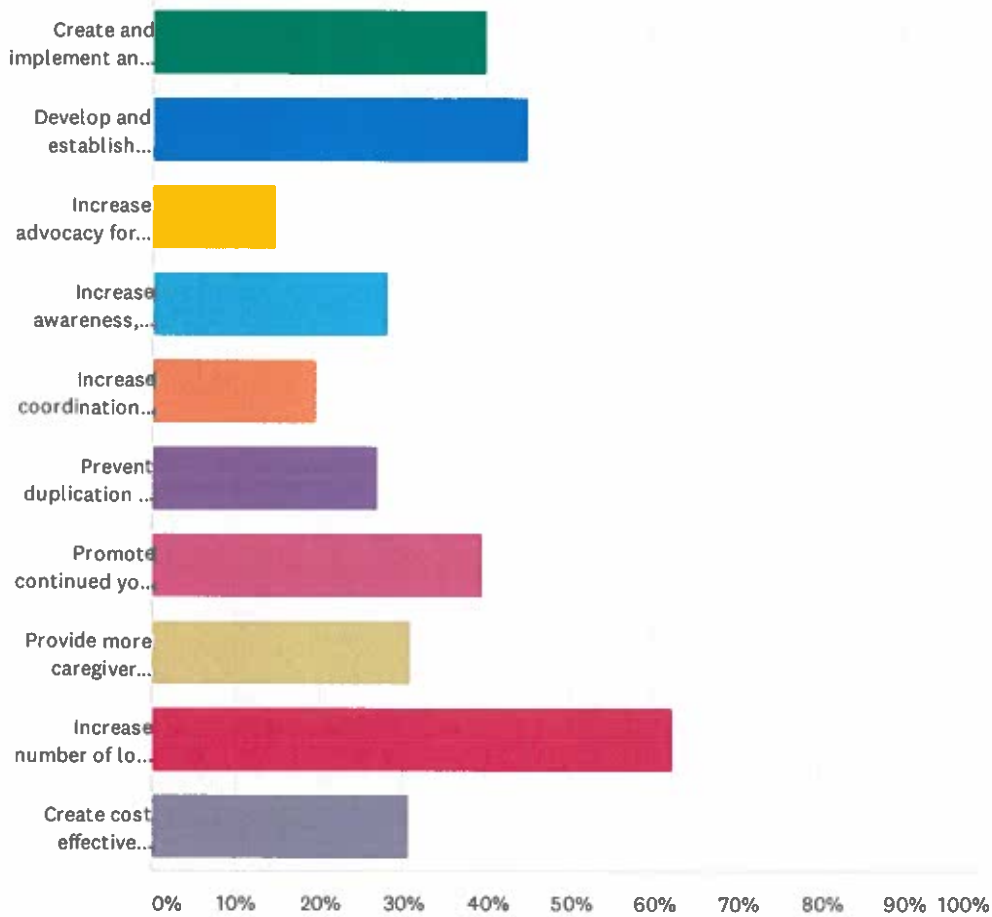

Almaguin Community Safety and Well Being Plan Survey 2020

| ANSWER CHOICES                                                                                                           | RESPONSES  |
|--------------------------------------------------------------------------------------------------------------------------|------------|
| Create and implement an online volunteer opportunities hub                                                               | 39.87% 126 |
| Develop and establish opportunities for community members to connect and gather for activities                           | 44.94% 142 |
| Increase advocacy for changes within personalized social services                                                        | 14.87% 47  |
| Increase awareness, accessibility and navigation of community services (extended hours, transportation, online services) | 28.16% 89  |
| Increase coordination and efforts to address issues associated with housing and homelessness                             | 19.62% 62  |
| Prevent duplication of services and coordinate better care of our community                                              | 26.90% 85  |
| Promote continued youth and adult education (literacy, skills training, apprenticeships)                                 | 39.56% 125 |
| Provide more caregiver supports                                                                                          | 31.01% 98  |
| Increase number of low cost recreation activities                                                                        | 62.34% 197 |
| Create cost effective public transportation between communities                                                          | 30.70% 97  |
| Total Respondents: 316                                                                                                   |            |



### Q34 What would your top solutions be for a safer community?

Answered: 340 Skipped: 105

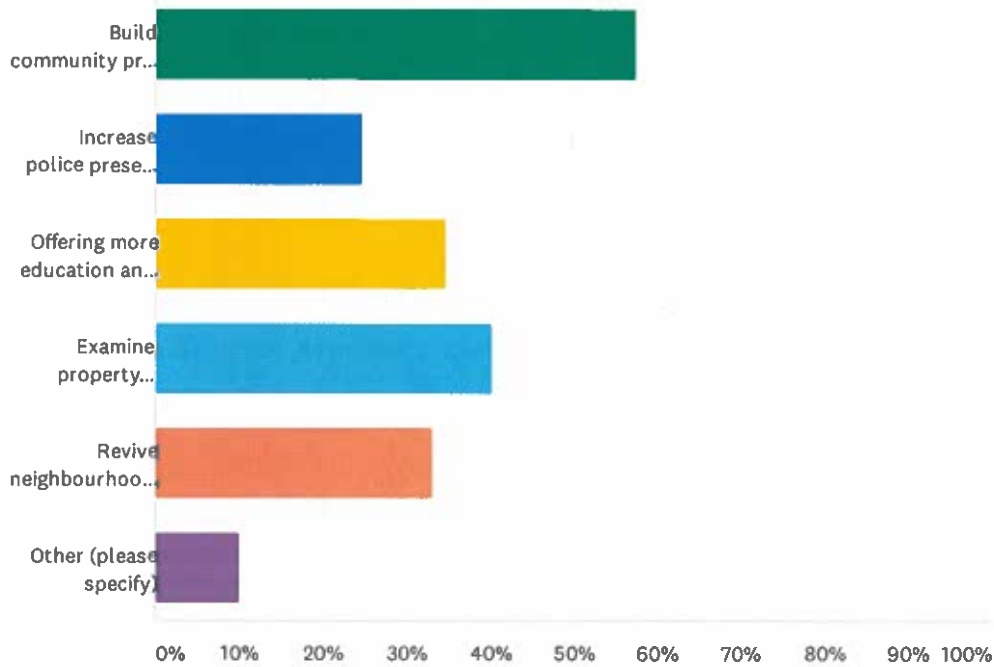

| ANSWER CHOICES                                                              | RESPONSES |     |
|-----------------------------------------------------------------------------|-----------|-----|
| Build community pride and foster personal accountability and responsibility | 57.65%    | 196 |
| Increase police presence                                                    | 25.00%    | 85  |
| Offering more education and awareness on needed topics                      | 35.00%    | 119 |
| Examine property standards to improve poor housing conditions               | 40.29%    | 137 |
| Revive neighbourhood watch programs                                         | 33.24%    | 113 |
| Other (please specify)                                                      | 10.00%    | 34  |
| Total Respondents: 340                                                      |           |     |

## Almaguin Community Safety and Well Being Plan Survey 2020

| #  | OTHER (PLEASE SPECIFY)                                                                                                                                                                                                                                                                                                                                                                                                                                                                                                                                              | DATE               |
|----|---------------------------------------------------------------------------------------------------------------------------------------------------------------------------------------------------------------------------------------------------------------------------------------------------------------------------------------------------------------------------------------------------------------------------------------------------------------------------------------------------------------------------------------------------------------------|--------------------|
| 1  | Traffic safety measures in residential roads. This would be safer for car drivers and it would make it possible to bike and walk safely.                                                                                                                                                                                                                                                                                                                                                                                                                            | 6/8/2020 1:15 AM   |
| 2  | Seasonal Residents often feel ignored in Community development and activities.                                                                                                                                                                                                                                                                                                                                                                                                                                                                                      | 6/4/2020 11:58 AM  |
| 3  | Plow West Bay Rd                                                                                                                                                                                                                                                                                                                                                                                                                                                                                                                                                    | 6/4/2020 11:04 AM  |
| 4  | Open carry, castle law, tighten bail conditions and sentences for criminals, form militia                                                                                                                                                                                                                                                                                                                                                                                                                                                                           | 5/26/2020 5:04 PM  |
| 5  | Monitor speeding on side roads and in town                                                                                                                                                                                                                                                                                                                                                                                                                                                                                                                          | 5/26/2020 2:42 PM  |
| 6  | STOP THE FRAUD, THE DECEIT, THE BULLYING and STOP IGNORING THE BUILDING CODE                                                                                                                                                                                                                                                                                                                                                                                                                                                                                        | 5/26/2020 7:45 AM  |
| 7  | Stakeholder participation in community devosion making                                                                                                                                                                                                                                                                                                                                                                                                                                                                                                              | 5/25/2020 7:22 PM  |
| 8  | STOP THE FRAUD, THE DECEIT, THE BULLYING                                                                                                                                                                                                                                                                                                                                                                                                                                                                                                                            | 5/25/2020 10:20 AM |
| 9  | Increase social assistance, disability base funding                                                                                                                                                                                                                                                                                                                                                                                                                                                                                                                 | 5/25/2020 10:18 AM |
| 10 | Drug enforcement, regardless if it's just the little guy and not the big player. All need to held accountable. Charges and supports need to be put in place; substance abuse, addiction treatment.                                                                                                                                                                                                                                                                                                                                                                  | 5/25/2020 10:06 AM |
| 11 | I feel we have a very safe community currently.                                                                                                                                                                                                                                                                                                                                                                                                                                                                                                                     | 5/18/2020 7:34 PM  |
| 12 | Much better roads, increased Fire Department budget for more equipment and manpower.                                                                                                                                                                                                                                                                                                                                                                                                                                                                                | 5/16/2020 8:49 AM  |
| 13 | Have nothing specific                                                                                                                                                                                                                                                                                                                                                                                                                                                                                                                                               | 5/16/2020 6:26 AM  |
| 14 | By law for clean up of some disgusting properties.                                                                                                                                                                                                                                                                                                                                                                                                                                                                                                                  | 5/15/2020 7:06 PM  |
| 15 | Get a doctor, Asap!                                                                                                                                                                                                                                                                                                                                                                                                                                                                                                                                                 | 5/14/2020 8:05 PM  |
| 16 | Active emergency responce centre                                                                                                                                                                                                                                                                                                                                                                                                                                                                                                                                    | 5/13/2020 9:03 PM  |
| 17 | This is an oddly specific question. I don't feel like my community is particularly unsafe. I'd need to see a published crime report to be able to offer an opinion on this. The response depends on the type of safety / crime issues we're dealing with.                                                                                                                                                                                                                                                                                                           | 5/13/2020 8:43 PM  |
| 18 | Create a community centre to keep kids from being bored                                                                                                                                                                                                                                                                                                                                                                                                                                                                                                             | 5/13/2020 7:35 PM  |
| 19 | teach children about healthy choices                                                                                                                                                                                                                                                                                                                                                                                                                                                                                                                                | 5/13/2020 6:47 PM  |
| 20 | Drug paraphernalia safety                                                                                                                                                                                                                                                                                                                                                                                                                                                                                                                                           | 5/13/2020 6:44 PM  |
| 21 | improved infrastructure; street lights, side walks                                                                                                                                                                                                                                                                                                                                                                                                                                                                                                                  | 5/13/2020 4:03 PM  |
| 22 | NO LOW INCOME HOUSING                                                                                                                                                                                                                                                                                                                                                                                                                                                                                                                                               | 5/13/2020 12:19 PM |
| 23 | improve community mass notification around emergency situations ncyacio                                                                                                                                                                                                                                                                                                                                                                                                                                                                                             | 5/13/2020 9:33 AM  |
| 24 | Community watch                                                                                                                                                                                                                                                                                                                                                                                                                                                                                                                                                     | 5/12/2020 11:28 PM |
| 25 | Bring universal spirituality to our teens to increase self respect lending moral support and provide a sense of belonging and involvement with the community lending helping hands to seniors etc .                                                                                                                                                                                                                                                                                                                                                                 | 5/12/2020 10:59 PM |
| 26 | Anything really                                                                                                                                                                                                                                                                                                                                                                                                                                                                                                                                                     | 5/12/2020 3:51 PM  |
| 27 | Work with local council and businesses to improve employment opportunities for young adults.                                                                                                                                                                                                                                                                                                                                                                                                                                                                        | 5/12/2020 2:05 PM  |
| 28 | I don't see our area as unsafe. Probably all on the above would help but I think our whole justice system needs to be revamped to PUNISH those who break the law, not let them out on parole after serving little if any of their sentence. On that topic, I think sentences don't fit the crimes in most cases. I have no problem with giving a person a break if they do something illegal but if they end up in trouble again, I think they should be PUNISHED. That means they serve full sentences and work while in prison to pay for their room and board!!! | 5/12/2020 1:02 PM  |
| 29 | STOP THE FRAUD, THE DECEIT, THE BULLYING                                                                                                                                                                                                                                                                                                                                                                                                                                                                                                                            | 5/12/2020 11:43 AM |
| 30 | Go out and make the community get involved highlight service clubs say hi                                                                                                                                                                                                                                                                                                                                                                                                                                                                                           | 5/11/2020 10:12 PM |

## Almaguin Community Safety and Well Being Plan Survey 2020

|    |                                                                                                                                                                                                                                                      |                   |
|----|------------------------------------------------------------------------------------------------------------------------------------------------------------------------------------------------------------------------------------------------------|-------------------|
| 31 | Town is a drive through. Give it the appearance of being a town. Emsdale                                                                                                                                                                             | 5/11/2020 9:37 PM |
| 32 | Job opportunities                                                                                                                                                                                                                                    | 5/11/2020 7:56 PM |
| 33 | access to local businesses - develop the current empty buildings that are contained throughout Ontario Street. The Village needs a vibrant downtown. I would be reluctant to have any young people in the downtown area due to the lack of activity. | 5/11/2020 4:14 PM |
| 34 | Revive downtown Burk's Falls                                                                                                                                                                                                                         | 5/11/2020 3:48 PM |

Community Agency Survey Results – Almaguin Community Safety and Well-being Plan  
2020

| <b>District of Parry Sound Social Services Administration Board (DSSAB)</b>                                                                                                                                                                                                                                                                                                                                                |                                                                                                                                                                                                                                                 |                                                                                                                                                                                                                                                                                                                                                                                                                                                                                  |
|----------------------------------------------------------------------------------------------------------------------------------------------------------------------------------------------------------------------------------------------------------------------------------------------------------------------------------------------------------------------------------------------------------------------------|-------------------------------------------------------------------------------------------------------------------------------------------------------------------------------------------------------------------------------------------------|----------------------------------------------------------------------------------------------------------------------------------------------------------------------------------------------------------------------------------------------------------------------------------------------------------------------------------------------------------------------------------------------------------------------------------------------------------------------------------|
| <b>Overview of Services</b>                                                                                                                                                                                                                                                                                                                                                                                                | <b>Top 5 Issues</b>                                                                                                                                                                                                                             | <b>Other</b>                                                                                                                                                                                                                                                                                                                                                                                                                                                                     |
| <ul style="list-style-type: none"> <li>• Community Housing</li> <li>• Housing Allowance</li> <li>• Rent Supplements</li> <li>• Homelessness Prevention</li> <li>• Ontario Works</li> <li>• Child Care Fee Subsidy</li> <li>• Early Learning &amp; Child Care Centres</li> <li>• Home Child Care</li> <li>• Inclusion Support Services</li> <li>• EarlyON</li> <li>• High Five</li> <li>• Violence Against Women</li> </ul> | <ul style="list-style-type: none"> <li>• Lack of housing</li> <li>• Lack of mental health and addictions services</li> <li>• Lack of primary health care services</li> <li>• Lack of transportation</li> <li>• Precarious employment</li> </ul> | <p>Coordination and collaboration between communities and agencies to appropriately support clients</p> <p>Low-cost recreation programming for everyone</p> <p>Access to health/addition services without having to leave the community</p> <p>Improving internet access to everyone</p> <p>Implementation of a “no wrong door” approach that encourages collaboration between communities and service providers to ensure that clients are accessing all necessary supports</p> |
| <b>Ontario Provincial Police (OPP)</b>                                                                                                                                                                                                                                                                                                                                                                                     |                                                                                                                                                                                                                                                 |                                                                                                                                                                                                                                                                                                                                                                                                                                                                                  |
| <b>Overview of Services</b>                                                                                                                                                                                                                                                                                                                                                                                                | <b>Top 5 Issues</b>                                                                                                                                                                                                                             | <b>Other</b>                                                                                                                                                                                                                                                                                                                                                                                                                                                                     |
| <ul style="list-style-type: none"> <li>• Protecting citizens</li> <li>• Upholding the law and preserving public safety</li> </ul>                                                                                                                                                                                                                                                                                          | <ul style="list-style-type: none"> <li>• Increase in reported violent crimes, including sexual assaults and human trafficking</li> <li>• Domestic disturbances</li> </ul>                                                                       | <p>Encourage collaboration with other agencies to the full extent of their services</p>                                                                                                                                                                                                                                                                                                                                                                                          |

|                                                                                                                                                                                                                                  |                                                                                                                                                                         |  |
|----------------------------------------------------------------------------------------------------------------------------------------------------------------------------------------------------------------------------------|-------------------------------------------------------------------------------------------------------------------------------------------------------------------------|--|
| <ul style="list-style-type: none"> <li>• Responding to emergencies, investigating crime and patrolling highways, trails and waterways</li> <li>• Building relationships with communities and support victims of crime</li> </ul> | <ul style="list-style-type: none"> <li>• Mental health (supporting people in crisis)</li> <li>• Impaired operation of motor vehicle</li> <li>• OPIOID crisis</li> </ul> |  |
|----------------------------------------------------------------------------------------------------------------------------------------------------------------------------------------------------------------------------------|-------------------------------------------------------------------------------------------------------------------------------------------------------------------------|--|

| <b>Muskoka Algonquin Healthcare (MAHC)</b>                                                                                                                                  |                                                                                                                                                                                                                                                                                                                                                                                                                       |                                                                                                                                                                                                                                                                                                                                                                                                                                                                                                                                                                                       |
|-----------------------------------------------------------------------------------------------------------------------------------------------------------------------------|-----------------------------------------------------------------------------------------------------------------------------------------------------------------------------------------------------------------------------------------------------------------------------------------------------------------------------------------------------------------------------------------------------------------------|---------------------------------------------------------------------------------------------------------------------------------------------------------------------------------------------------------------------------------------------------------------------------------------------------------------------------------------------------------------------------------------------------------------------------------------------------------------------------------------------------------------------------------------------------------------------------------------|
| Overview of Services                                                                                                                                                        | Top 5 Issues                                                                                                                                                                                                                                                                                                                                                                                                          | Other                                                                                                                                                                                                                                                                                                                                                                                                                                                                                                                                                                                 |
| <ul style="list-style-type: none"> <li>• X-ray, lab services, physiotherapy through Health Centre</li> <li>• Emergency and IP care through acute care facilities</li> </ul> | <ul style="list-style-type: none"> <li>• Ontario Health Team development – changing roles of providers and institutions in evolving healthcare model</li> <li>• Funding challenges</li> <li>• Capital Redevelopment project-working on local share planning</li> <li>• Capital equipment – capital needs far exceeds ability of foundations to raise enough funds annually</li> <li>• Aging infrastructure</li> </ul> | <p>Encourage Almaguin to work with Muskoka and Area Ontario Healthcare Team to advance the safety and wellbeing of residents in Almaguin</p> <p>Almaguin residents based on the following residence codes (4-year comparison 2016-2019):</p> <ul style="list-style-type: none"> <li>- Armour (4510)</li> <li>- Machar (4520)</li> <li>- Ryerson (4526)</li> <li>- Burk's Falls (4505)</li> <li>- Magnetawan (4546 &amp; 4551)</li> <li>- South River (4508)</li> <li>- Joly (4519)</li> <li>- McMurrich/Monteith (4552)</li> <li>- Strong (4527)</li> <li>- Kearney (4501)</li> </ul> |

|                                                                                                                                                                                                                                                                                                             |                                                                                                                                                                                                                                 |                                                                                                                                          |
|-------------------------------------------------------------------------------------------------------------------------------------------------------------------------------------------------------------------------------------------------------------------------------------------------------------|---------------------------------------------------------------------------------------------------------------------------------------------------------------------------------------------------------------------------------|------------------------------------------------------------------------------------------------------------------------------------------|
|                                                                                                                                                                                                                                                                                                             |                                                                                                                                                                                                                                 | <ul style="list-style-type: none"> <li>- Perry (4525)</li> <li>- Sundridge (4509)</li> </ul>                                             |
| <b>Women's Own Resource Centre</b>                                                                                                                                                                                                                                                                          |                                                                                                                                                                                                                                 |                                                                                                                                          |
| Overview of Services                                                                                                                                                                                                                                                                                        | Top 5 Issues                                                                                                                                                                                                                    | Other                                                                                                                                    |
| <ul style="list-style-type: none"> <li>• Life Skills Training</li> <li>• Entrepreneurial Skills Training</li> <li>• 1:1 consults</li> <li>• Crisis</li> <li>• Donation network</li> <li>• Referral services</li> <li>• Computer access and assistance</li> <li>• Business luncheons and services</li> </ul> | <ul style="list-style-type: none"> <li>• Lack of funding- same since 2000</li> <li>• Transportation – barrier to participant access</li> <li>• Clients seeking out opportunities for social inclusion and networking</li> </ul> | <p>More regional opportunities for networking and social inclusion</p> <p>Clients are predominately female between the ages of 18-70</p> |
| <b>Burk's Falls and District Food Bank</b>                                                                                                                                                                                                                                                                  |                                                                                                                                                                                                                                 |                                                                                                                                          |
| Overview of Services                                                                                                                                                                                                                                                                                        | Top 5 Issues                                                                                                                                                                                                                    | Other                                                                                                                                    |
| <ul style="list-style-type: none"> <li>• Food bank</li> <li>• Christmas Basket Program</li> </ul>                                                                                                                                                                                                           | <ul style="list-style-type: none"> <li>• Location – not accessible, landlord issues</li> <li>• Staffing – require treasurer</li> <li>• Increased usage – 2019 – 6% increase</li> </ul>                                          |                                                                                                                                          |
| <b>Food Bank – Sundridge</b>                                                                                                                                                                                                                                                                                |                                                                                                                                                                                                                                 |                                                                                                                                          |
| Overview of Services                                                                                                                                                                                                                                                                                        | Top 5 Issues                                                                                                                                                                                                                    | Other                                                                                                                                    |
| <ul style="list-style-type: none"> <li>• Food bank</li> </ul>                                                                                                                                                                                                                                               | <ul style="list-style-type: none"> <li>• Affordable food – prices high in rural areas</li> <li>• Employment - Insufficient opportunities</li> </ul>                                                                             | Appears that when clients find employment they do not utilize food bank                                                                  |

**ALMAGUIN COMMUNITY ECONOMIC DEVELOPMENT  
(ACED)**

**MINUTES  
January 17, 2022**

A regular meeting of the ACED Board was held at the Township of Armour Office and virtually on January 17, 2022 at 6:00 pm.

Present: Wendy Whitwell, Township of Armour, Chair  
Margaret Ann MacPhail, Township of Perry  
Tim Brunton, Municipality of Magnetawan  
Lyle Hall, Village of Sundridge  
Kelly Elik, Township of Strong  
Delynne Patterson, Township of Ryerson  
Joseph Vella, Township of Ryerson  
John Wilson, Village of Burk's Falls  
Melanie Alkins, MNDMNR  
Ron Begin, FedNor  
Peter McIsaac, Municipality of Powassan  
Brenda Scott, Village of South River

Regrets: Tim Bryson, Township of Joly  
Jennifer Farquhar, AHCC Representative

Staff: Dave Gray, Director of Economic Development  
John Theriault, Township of Armour  
Ciara Ryan, Regional Brand Coordinator  
Courtney Metcalf, Economic Development Officer  
Nicole Gourlay, Municipality of Magnetawan

**Call to Order**

The meeting was called to order at 6:05 pm.

**Minutes**

The minutes of the meeting of Monday, December 13, 2021 meeting were adopted as amended.

**Director of Economic Development (DED) Report**

The Director of Economic Development discussed changing the reporting period for the monthly reports to based on a calendar month. The Board did not have any objections to the change.

## **2022 Workplan**

The Director of Economic Development advised the Board that he would be sending out the 2022 workplan by the end of the week. He is asking all Board members to review the plan and advise of any concerns or proposed changes so these can be discussed at the February meeting.

One concern raised was the increase in the cost of housing in our region and the impacts of housing market activity on communities. It was expressed that councils and ACED should seek to analyze and understand these impacts and identify ways to address opportunities and possible threats (EG. impacts to emergency services).

## **Regional Brand Strategy Implementation**

The Director of Economic Development and the Regional Brand Coordinator presented a staff report and an evaluation chart on the results of the Request for Proposals (RFP) ACED solicited to provide web development services to create a regional website. The Board discussed the results and passed a resolution recommending that the proposal from 9 Lives Design be accepted.

## **2021 Annual Report**

The ACED Board reviewed and discussed the 2021 Annual Report presented by the Director of Economic Development.

The report summarized all the activities of the Economic Development Department for 2021. Highlights included:

1. Activities intended to support businesses in any capacity, including, but not limited to, business start ups, business expansions, general business support, online presence building, networking, and business site selection.
2. Activities that support community and recreation-based organizations and supporting community and recreation-based projects undertaken by municipalities where efforts benefit multiple partners.
3. Activities that are intended to increase the region's ability to attract investment of any kind. Typically, capacity building initiatives provide less immediately tangible results, however, in many cases they provide a foundation for future activities or growth.
4. Activities intended to market or promote any aspect of the region.
5. Activities geared to draw enhanced attention to regional features and assets.

The report highlighted the fact that some of the items in the 2021 workplan could not be completed because COVID-19 required that some of the priorities for projects change. The 2022 workplan should include some of these items. Board members commented that the report was very informative.



## **Post 2023 ACED Department Outlook and Funding**

The Board inquired when the different funding options for ACED would be presented. The Director of Economic Development advised that these should be ready for the next ACED meeting.

### **Updates**

#### **FedNor**

Ron Begin commented that the ACED 2021 Annual Report was very well done and contained a lot of information relevant to the work that was done. He wondered how much more ACED could do to help businesses. He gave credit to ACED for the fact that if they were not there, the region could have lost a lot more than it did because of COVID-19.

He advised that intake of applications has slowed down. Tourism programs are still available. There is still a challenge dealing with COVID-19 and he appreciated the discussion that the Board had on helping the region.

#### **MENDM**

Melanie Alkins commented that the 2021 Annual Report was well done. If anyone has outstanding applications, please send them in as soon as possible. Funding for internships is available and these can help with staff shortages. The reconnect program has received new funding and applications can be presented for evaluation. There is a \$10,000 grant available at this time for businesses to help cope with the COVID-19 shutdown.

### **Resolutions**

1. 2022-001– Moved by Kelly Elik; Seconded by Delynne Patterson;  
Be it resolved that the Almaguin Community Economic Development Board approve the minutes of December 13<sup>th</sup>, 2021, as circulated. Carried
2. 2022-002 – Moved by Lyle Hall; Seconded by John Wilson;  
Be it resolved that the Almaguin Community Economic development Board have received and reviewed the Almaguin Regional Website Services staff report and recommend that the Township of Armour award the service contract to 9 Lives Design at the cost of \$12,000 plus HST.

#### **Adjournment**

3. 2022-003 – Moved by Peter McIsaac;  
Be it resolved that the Almaguin Community Economic Development Board adjourn the January 17<sup>th</sup>, 2022 ACED meeting at 7:29 p.m. Carried

The next meeting will be February 28, 2022 at 6:00 p.m. If this change, members will be advised.

# 2021 ANNUAL REPORT



## Table of Contents

|                                                          |    |
|----------------------------------------------------------|----|
| Introduction .....                                       | 2  |
| 2021 ACED Activities Overview.....                       | 2  |
| 1.0 Business Support and Development.....                | 3  |
| A. Core Business Support.....                            | 3  |
| B. BR&E By Industry .....                                | 4  |
| C. Digital Main Street and Online Presence Support ..... | 5  |
| D. Business Support Events.....                          | 6  |
| E. AHCC Partnerships .....                               | 7  |
| F. Win This Space Almaguin .....                         | 7  |
| 2.0 Community Development.....                           | 8  |
| A. Community Program G.R.O .....                         | 8  |
| B. Village Impressions Program .....                     | 8  |
| C. Regional Recreation Support .....                     | 8  |
| 3.0 Economic Capacity Building .....                     | 10 |
| A. Operation Open 4 Business .....                       | 10 |
| B. Broadband Development.....                            | 10 |
| C. Transportation Development .....                      | 10 |
| D. Business Opportunity Profiling .....                  | 11 |
| E. AHSS Student Engagement .....                         | 11 |
| 4.0 Marketing and Promotion.....                         | 12 |
| General Marketing Overview.....                          | 12 |
| A. Brand Strategy Implementation .....                   | 12 |
| B. AG Strategy Implementation .....                      | 13 |
| C. Tourism Promotion .....                               | 13 |
| D. Shop In Almaguin Campaigns .....                      | 14 |
| 5.0 Special Events & Projects.....                       | 16 |

---

## Introduction

The Almaguin Community Economic Development (ACED) Team is pleased to present the 2021 Annual Report which includes a summary of initiatives, activities, and results from the year. Initially, the focus for the team was to support a return to normalcy for businesses, organizations, and other stakeholders as the effects of the pandemic subsided. The goal at the outset was to continue developing and implementing initiatives based on recommendations from guiding strategies while building capacity for internal and external growth. While this goal was achieved in several capacities, the need to find innovative ways to support businesses, tourism, and cultural assets became evident, which prompted some deviation from the initial 2021 Work Plan.

This partial change of direction, combined with several other external trends and factors, brought about some very interesting benefits to the regional economy. New residents and visitors were met with many ways to discover and experience Almaguin; businesses, artists and organizations were connected both with support opportunities and different ways to connect with people; and regional supportive partners came together to find creative ways to help meet the needs of the region. While the year may have had its twists and turns, the mandate of ACED was upheld, and positive momentum was maintained.

---

*“ACED will develop our economy and regional environment through taking strategic action and stewarding strong relationships between municipalities, the business community, community organizations and economic development stakeholders.”*

---

## 2021 ACED Activities Overview

The 2021 ACED Work Plan reflected a re-categorization of core functions versus the 2020 plan. The purpose behind the new categories was to better represent what ACED does within the region. A recap of these themes is provided below:

1. **Business Support and Development:** Activities intended to support businesses in any capacity. This includes but is not limited to start up, expansion, general business support, online presence building, networking, and site selection.
2. **Community Development:** Activities that support community and recreation-based organizations; and supporting community and recreation-based projects undertaken by municipalities where efforts benefit multiple partners.
3. **Economic Capacity Building:** Activities that are intended to increase the region’s ability to attract investment of any kind. Typically, capacity building initiatives provide less immediately tangible results; however, in many cases they provide a foundation for future activities or growth,
4. **Marketing and Promotion:** Activities intended to market or promote any aspect of the region.
5. **Special Events and Projects:** Activities geared to draw enhanced attention to regional features and assets

## 1.0 Business Support and Development

### A. Core Business Support

The information provided below represents the direct business interactions that ACED staff had with businesses, operators, and organizations throughout the region as well as information that has been reported from supportive agencies throughout the region.

Figure 1 – KPI Results

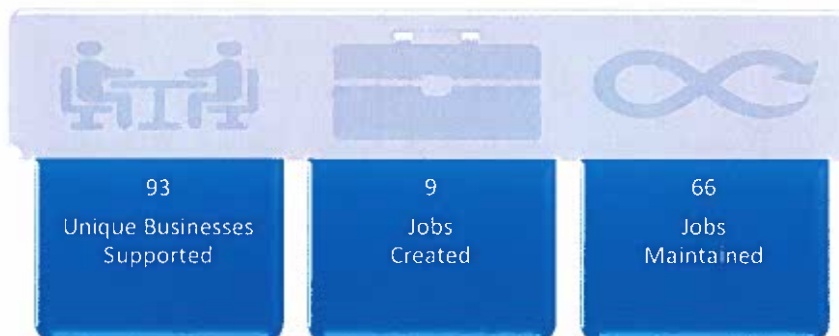

### Other Key Results

|                                        | Count   | YOY Change |
|----------------------------------------|---------|------------|
| Total Business Interactions            | 133     | - 1.5%     |
| Total Unique Business Clients          | 91      | + 33%      |
| Supported Start Ups                    | 5       | + 25%      |
| Actual Expansions                      | 3       | + 200%     |
| Direct Support Organization Referrals  | 72      | +140%      |
| Total Known Private Sector Investment* | \$1.79M |            |
| Jobs Created**                         | 9       | - 22%      |
| Jobs Maintained**                      | 66      | +94%       |

\* Includes known investments reported by NOHFC & NECO, see figure 2 below.

\*\* Includes, where available, information provided by supportive agencies.

Figure 2 – Data reported from NOHFC & NECO

The figures noted below have been reported by each respective organization and/or directly from business operators. ACED supports access to these programs through direct client referrals, bulk email communications and in a few cases, direct application support.

| Organization | Program Name           | Businesses Served | Total Investment   | Grants/Funds Awarded |
|--------------|------------------------|-------------------|--------------------|----------------------|
| NECO CFDC    | RRRF & Investment Fund | 21                | \$517,074          | \$47,907             |
| NOHFC        | N.O.R.P.               | 30                | \$1,274,220        | \$647,646            |
|              |                        |                   | <b>\$1,791,294</b> | <b>\$695,553</b>     |

Figure 3: Interactions by Type

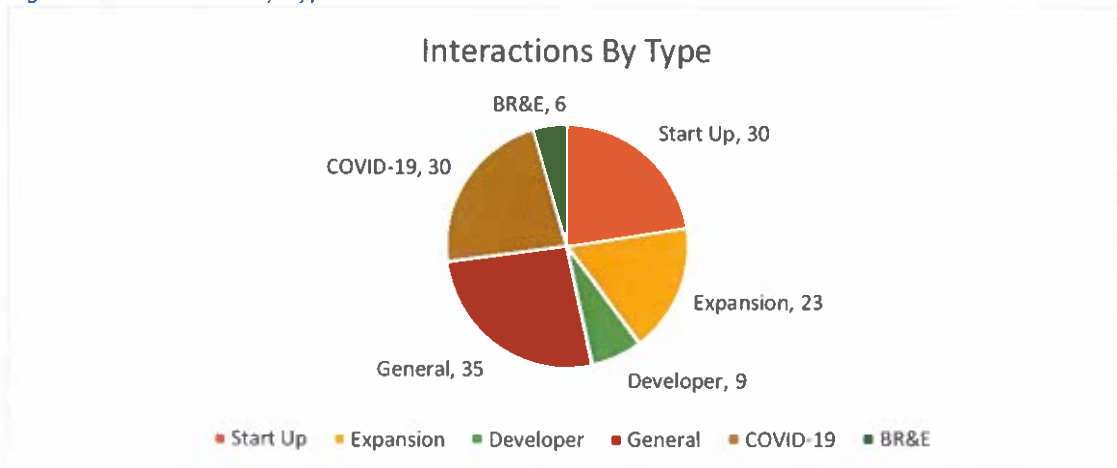

Figure 4: Unique Businesses By Location

| Municipality       | Count | Municipality        | Count |
|--------------------|-------|---------------------|-------|
| Perry              | 8     | Strong              | 7     |
| Kearney            | 4     | Sundridge           | 8     |
| McMurrich Monteith | 5     | Joly                | 1     |
| Magnetawan         | 5     | Machar              | 2     |
| Armour             | 11    | South River         | 3     |
| Ryerson            | 4     | Powassan            | 7     |
| Burk's Falls       | 19    | Unorganized / Other | 7     |

B. BR&E By Industry

The 2020 Manufacturing and Forestry BR&E was completed in Q1 of 2021. The results displayed below reflect the total results across both years. The 2021 Work Plan reflected the continuation of the BR&E by industry with the Construction sector, however, this was postponed due to the commencement of the building season and ACED's efforts in the Staycation in Almaguin Initiative.

*KPI RESULTS: 6 Interview Completed VS. 30 Projected*

Figure 5: Manufacturing & Forestry BR&E Results

|                                   | 2020                     | 2021             | Total     |
|-----------------------------------|--------------------------|------------------|-----------|
| <b>Businesses Interviewed:</b>    | 11 (7 on-site, 4 Remote) | 6                | <b>17</b> |
| <b>'Green Flag' Instances</b>     | 6 (Across 4 businesses)  | 2 (2 businesses) | <b>8</b>  |
| Support Agency Referrals          | 4                        | 5                | <b>9</b>  |
| <b>'Red Flag' Instances</b>       | 1                        | 1 (2020 Client)  | <b>2</b>  |
| <b>Direct Support Provided</b>    | 1                        | 2                | <b>3</b>  |
| <b>Supply Chain Info Provided</b> | 3                        | 2                | <b>5</b>  |
| Supply Chain Info Follow Ups      |                          | 14               | <b>14</b> |

C. Digital Main Street and Online Presence Support

ACED Staff continued to provide on-line presence support to Almaguin businesses following the completion of the Digital Main Street 2.0 Program, which ended on January 31, 2021. Figures 6 and 7 summarize the types of services provided as well as a breakdown of unique businesses serviced by municipality up to September of 2021.

As of October 2021, the Digital Main Street 3.0 program launched, which involved Almaguin being served through the Business Centre Nipissing Parry Sound. Figure 8 illustrates the results reported from The Business Centre.

*KPI RESULTS: 37 Business Served VS. 40 Projected*

Figure 6 – Service Breakdown

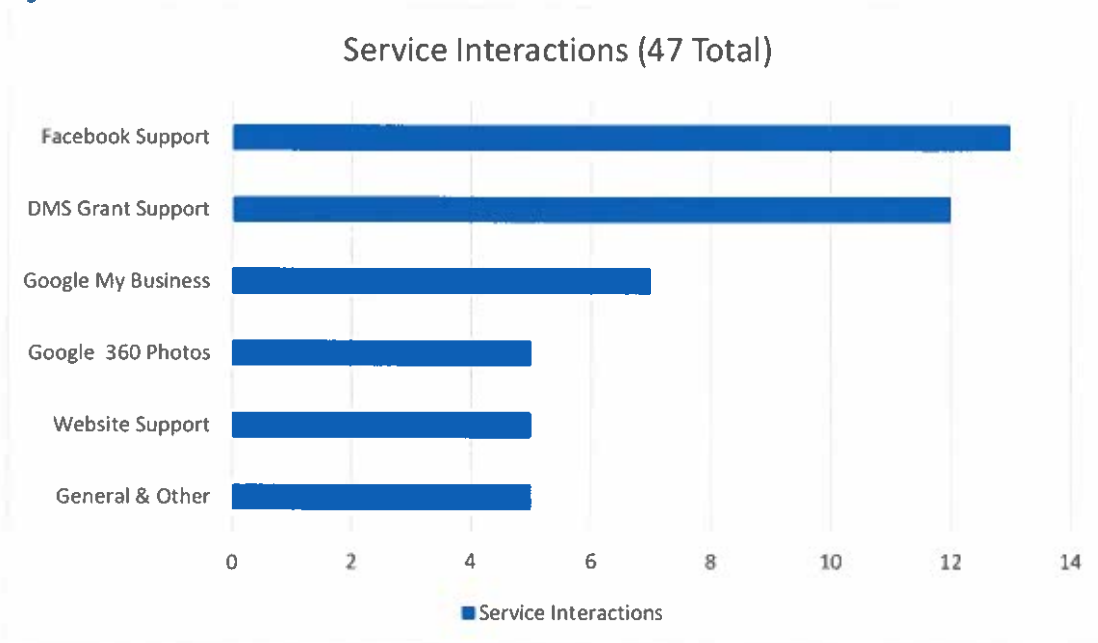

Figure 7 – Unique Businesses by Municipality

Online presence support was provided to businesses based on needs identified through core business support, referrals from supportive partners or via in-bound calls.

|                           |          |                    |          |
|---------------------------|----------|--------------------|----------|
| <b>Perry</b>              | <b>1</b> | <b>Strong</b>      | <b>2</b> |
| <b>Kearney</b>            | <b>1</b> | <b>Sundridge</b>   | <b>5</b> |
| <b>McMurrich Monteith</b> | <b>4</b> | <b>Joly</b>        | <b>0</b> |
| <b>Magnetawan</b>         | <b>0</b> | <b>Machar</b>      | <b>0</b> |
| <b>Armour</b>             | <b>1</b> | <b>South River</b> | <b>0</b> |

|              |   |                     |   |
|--------------|---|---------------------|---|
| Ryerson      | 1 | Powassan            | 1 |
| Burk's Falls | 4 | Unorganized / Other | 2 |

Figure 8: DMS 3.0 Highlights

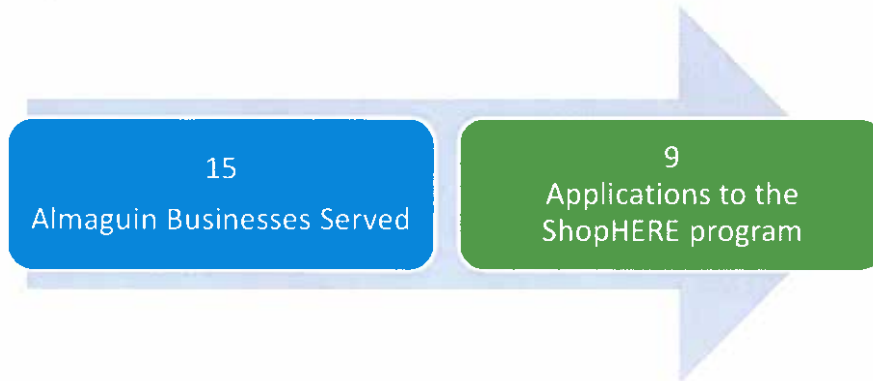

D. Business Support Events

In 2021, The ACED Team played a mostly supportive role by partnering with regional support agencies to deliver support events targeting employers throughout the region. Partners included Employment North, The Labour Market Group (LMG), The Almaguin Highlands Chamber of Commerce (AHCC) and the Ministry of Northern Development, Mines, Natural Resources, and Forestry (MNDMNR).

*KPI RESULTS: 3 EVENTS HOSTED VS. 5 PROJECTED;  
148 BUSINESS ATTENDEES VS. 150 Projected*

Figure 9 – Business Support Events





### E. AHCC Partnerships

Throughout 2021, the Almaguin Highlands Chamber of Commerce (AHCC) and ACED Staff partnered on several major initiatives.

#### *Welcome Wagon Program*

Staff supported the development of the AHCC Welcome Wagon Program. The program will provide a variety of useful information about supports available throughout the region as well as an initial introduction for the AHCC. The AHCC has committed to developing an initial 25 packages as a pilot; once completed, the effectiveness of the program will be assessed.

#### *International Women's Day*

The Influential Women of Almaguin Campaign was developed in partnership with the AHCC to celebrate impactful women throughout the region. Each of the nominees were showcased on the ACED Facebook Page and on a dedicated page on the [investalmaguin.ca](http://investalmaguin.ca) website.

*Figure 10 -Influential Women in Almaguin*

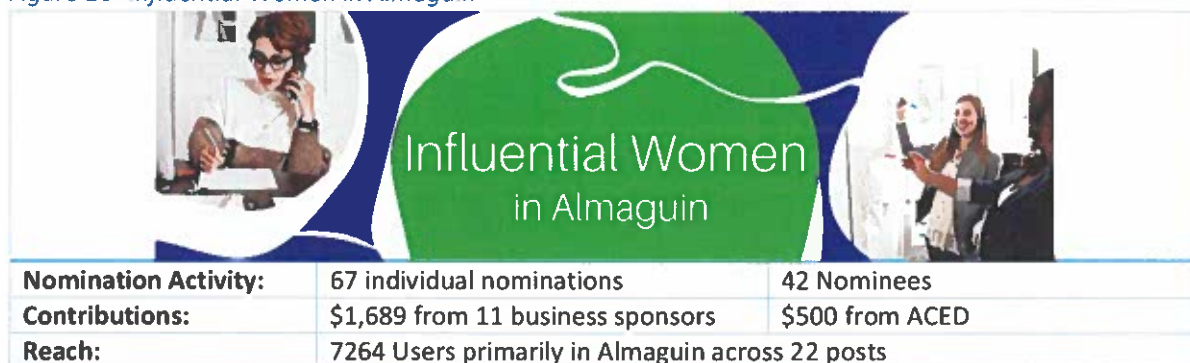

### F. Win This Space Almaguin

ACED Staff are supporting the Village of Burk's Falls in the development and deployment of their Win This Space initiative. The Business Centre Nipissing Parry Sound, The Women's Own Resource Centre and NECO CFDC have also been engaged to support the program, which will roll out in Q1 of 2022. The target for program completion and business occupancy is the Victoria Day weekend in May. ACED Staff will be participating in the program by offering support for partnership development, marketing, and implementation support as required.

The program will feature the following key components:

1. **Entrepreneurial Supports:** Business plan writing workshop, regional support network development, and other benefits supported by regional support organizations.
2. **Public Private Partnerships:** Two privately owned locations are being considered for inclusion based on participant uptake. Lease amounts through the first year will be partially or completely subsidized based on the final terms of the program and the agreed contributions from private and public sector partners.
3. **Program in a Box:** all program components and results will be packaged to allow for communities throughout the region to implement the program in the future.

---

*KPI RESULTS: 3 Locations Established (by Burk's Falls) VS. 2 Projected;  
0 participants in 2021 VS. 5 projected.*

---

## 2.0 Community Development

### A. Community Program G.R.O



ACED Staff have developed the G.R.O. Program which includes course materials and the G.R.O. workbook. Staff began marketing the program via email and social media in Q3 of 2021. These methods did not generate interest from support organizations, which prompted a direct phone approach. Agricultural societies have been contacted as a preliminary focal group with other groups to follow.

---

*KPI RESULTS: 1 Organization Supported (2 Pending) VS. 5 Projected;  
0 Volunteer Positions marketed VS. 15 Projected*

---

### B. Village Impressions Program

The Village Impressions Program was not pursued in 2021 as reported on the September 27<sup>th</sup> Directors report. Interest in the program will be reassessed in the Spring of 2022.

### C. Regional Recreation Support

#### *Promote and support the development of the Driftscape Platform*

ACED Staff supported the exploration of the Driftscape Platform early in 2021. Burk's Falls and Perry Township have pursued the platform and are actively listing points of interest throughout their communities. ACED Staff had limited involvement with the set-up process; however, they provided a description for the Villages of Almaguin 'parent' layer on the Driftscape app. Currently there are 16 points of interest for the region that are being promoted through the service.

#### *Support the Development of Experience Itineraries*

ACED Staff participated in the Great Taste of Ontario Road Trip led by the Ontario Culinary Tourism Alliance. Staff produced several tourism itineraries and an Almaguin Passport that were promoted through the program. Many Almaguin businesses and experiences were supported and promoted through this initiative as noted below.

Figure 11 – Great Taste of Ontario Results

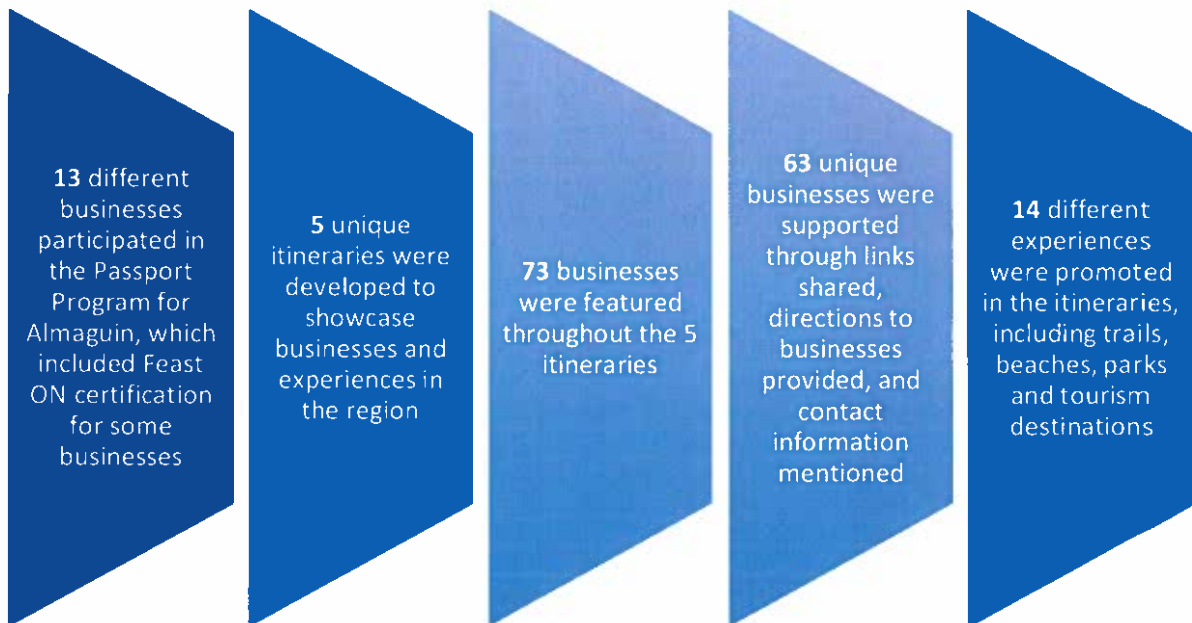

#### *Almaguin Highlands Tourism Website Partnerships*

The development of the Almaguin Regional website through the Brand Strategy implementation will involve the decommissioning of the current Almaguin Highlands Tourism site. The content and information from the site will be kept and included in the tourism component of the new site. Municipal and community organization partnerships will be sought when the new site is under construction, which will allow for a one-time training process.

#### *Staycation in Almaguin*

The Staycation in Almaguin initiative, which is reported in further detail below and in the Staycation in Almaguin Final Report, involved significant regional partnerships and produced many positive benefits to recreation and culture throughout the region.

---

*KPI RESULTS: 14 experiences promoted VS. 25 Projected (Great Taste of Ontario); 2 partnerships created VS. 2 Projected*

---

### 3.0 Economic Capacity Building

#### A. Operation Open 4 Business

Through Operation Open 4 Business, ACED Staff met with staff members of five municipalities to review several items such as ACED's core services to businesses, support that can be provided to businesses and investment clients and current plans/priorities that municipalities have in place. Other points included an overview of the communication process between ACED and businesses/investors and how ACED can offer support for municipally specific projects that are consistent with community or economic development.

---

*KPI RESULTS – 5 Municipalities Engaged VS. 5 Projected*

---

#### B. Broadband Development

For 2021, ACED Staff focused on maintaining an awareness of the status of broadband funding applications, sharing municipally specific data made available through Blue Sky Net's BAEMAP system and support any active expansion projects that they were invited to.

- ✓ Staff participated in the planning phase of the Lakeland Networks expansion in South Almaguin. This project was funded by the Universal Broadband Fund and promises to bring high-speed internet to 1,300 unserved households.
- ✓ Staff assisted in planning the extension of fiber optic services to the Armour Township Industrial Parks (planned for completion in 2022). This extension is complementary to the project noted above and adds approximately five residential households and two development properties.
- ✓ Staff reviewed municipal coverage profiles with five municipalities and circulated information regarding changes to the provincial broadband funding structure and their impact to existing funding applications.

---

*KPI RESULTS – 2 Projects Supported; 7 Advocacy Effort Vs. 14 Projected*

---

#### C. Transportation Development

Throughout the year, ACED participated in several activities to support the research and development of transportation solutions in the region.

1. 2021 Parry Sound District Transportation Survey – Supported the planning, development, marketing, and distribution of the survey in partnership with The Labour Market Group and the YMCA of Simcoe Muskoka.
  - a. The results from the survey have been posted on the ACED website and forwarded to several transportation providers.
2. Private Sector Transportation Service Exploration – Staff supported the exploration process of two transportation service providers who had expressed an interest in serving Almaguin. Both

providers concluded that significant subsidization would be required to maintain service levels and service reliability.

3. Ontario Northlander Rail Service Advocacy – Staff advocated on behalf of ACED for Almaguin’s consideration for a stop along the newly announced return of Northlander Rail Service. Staff are positioned to support efforts or projects pursuant to Almaguin’s inclusion along the service line.

---

*KPI RESULTS – 2 Projects supported VS. 1 Projected*

---

#### D. Business Opportunity Profiling

This project was not undertaken in 2021.

#### E. AHSS Student Engagement

ACED Staff worked with AHSS Faculty to pilot a longitudinal study aimed at understanding the goals of graduating students. The objectives of 2021 were to:

1. Promote and support the Summer Company Program. Attempts were made to coordinate a presentation from The Business Centre, but due to class scheduling changes to accommodate Public Health recommendations during the COVID pandemic, the school was unable to accommodate the presentation.
2. Design a graduating class exit interview process to identify opportunities to reattract youth. A survey was created through Survey Monkey and was shared through ACED social media and AHSS social media. The response uptake on the survey was not statistically significant, so further online data collection occurred by accessing information presented from graduate questionnaires via the AHSS Virtual Grad 2021- YouTube. ACED Staff produced the AHSS Student Engagement Report which can be used to compare data collected in future years.

---

*KPI RESULTS: 1 Initiative Launched VS. 2 Projected*

---

## 4.0 Marketing and Promotion

### General Marketing Overview

Figure 12 – Social Media Growth

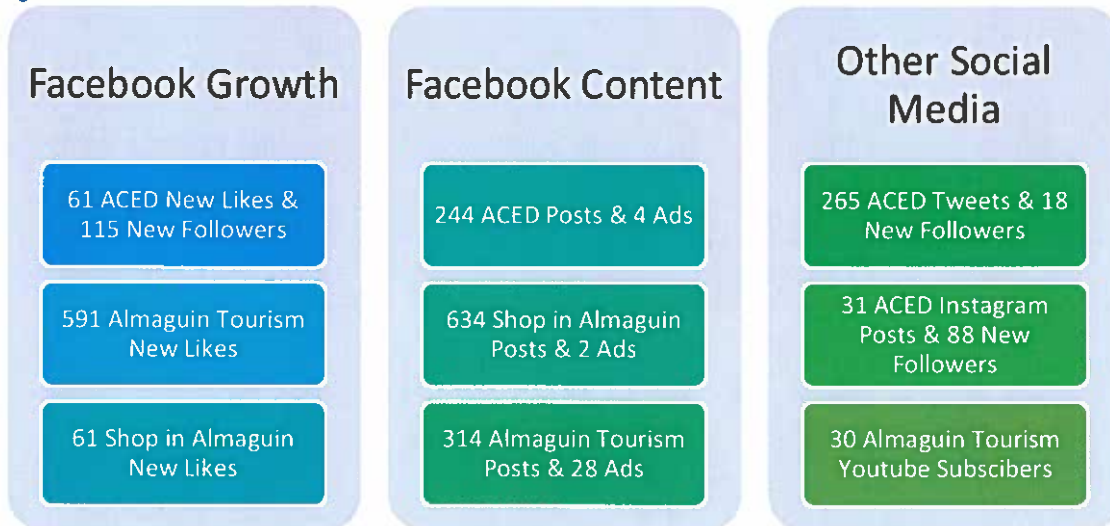

### A. Brand Strategy Implementation

In 2021 ACED made the first steps towards implementing the Regional Brand Strategy including:

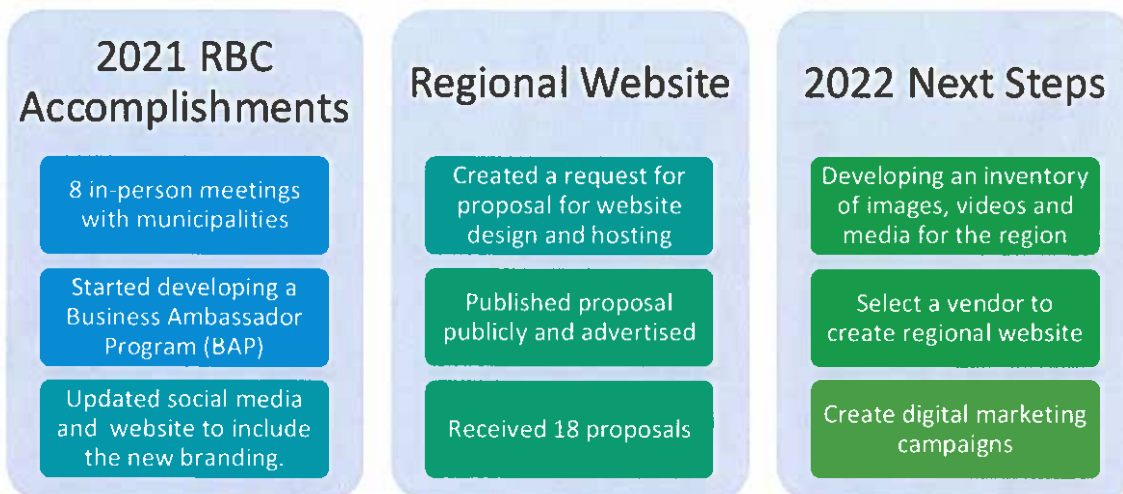

## B. AG Strategy Implementation

Several recommendations from the 2020 Agriculture and Culinary Stakeholder Engagement Strategy were pursued throughout 2021. ACED Staff sought the support of a group of seven agricultural stakeholders throughout the region to provide feedback and direction regarding several initiatives.

- ✓ The working group launched a trial of the Facebook Workplaces platform. The group currently has the original 7 members and will look to add new members in 2022.
- ✓ The Eat Local Spring Newsletter was created using content and articles from local business operators.
- ✓ The Tastes of Almaguin Food Truck Bingo campaign through Staycation in Almaguin promoted 30 restaurants across the region while encouraging food tourism.
- ✓ The Shop in Almaguin Facebook Page was used to promote, share, and celebrate food within its 629 posts, shares, and advertising, while growing its audience by 13%.
- ✓ 12 agriculture and culinary experiences were developed and/or promoted through Staycation in Almaguin which were enjoyed by over 1000 participants.
- ✓ Staff promoted access to farming & culinary opportunities as well as support and learning opportunities.

---

*KPI RESULTS – 6 Initiatives Undertaken VS. 7 Projected*

---

## C. Tourism Promotion

The ACED Team invested significant efforts in promoting tourism throughout the region which focused on celebrating multiple sectors such as arts, recreation, culture, culinary and other sectors.

### *Redevelopment of the Almaguin Highlands Tourism Website*

Through the Almaguin Brand Strategy Implementation process, the Almaguin Highlands Tourism website will be redeveloped into single regional website as a part of the Brand Hub for the region. Further advancement will occur throughout 2022.

### *Finalize the Great Taste of Ontario Road Trip Itineraries*

This initiative was successfully completed and reported on in section 2C (Figure 11).

*Promote snowmobiling Content in partnership with Explorer’s Edge*

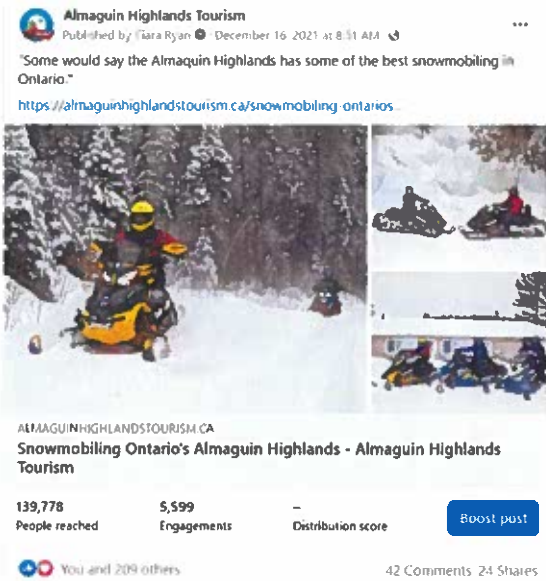

The content partnership with Explorer’s Edge was executed in Q4 of 2021 which involved the social media promotion of peak-season snowmobiling via the article produced in the late winter of 2020. Below is a snapshot of mid-promotion results taken during the drafting of this report.

*Promoted recreational trail usage, events, and activities in partnership with Discovery Routes*

Through Staycation in Almaguin, 8 experiences were developed and promoted that encouraged access to local trail systems including the Almaguin Harvest Spin, the Bear Chair Trail Race, and the Pathways to the Forgotten Trails experience.

KPI - 5 G.T.O. Road Trip Itineraries Developed VS. 2 Projected; AHT Website scheduled for redevelopment in 2022

D. Shop In Almaguin Campaigns

*Taste of Almaguin Culinary Bingo*

Promoted through Staycation in Almaguin, the Taste of Almaguin Bingo campaign encouraged food tourism by encouraging residents and visitors to explore the regions restaurant and food truck offerings in the pursuit of filling up their bingo cards.

Figure 13 – Taste of Almaguin Results

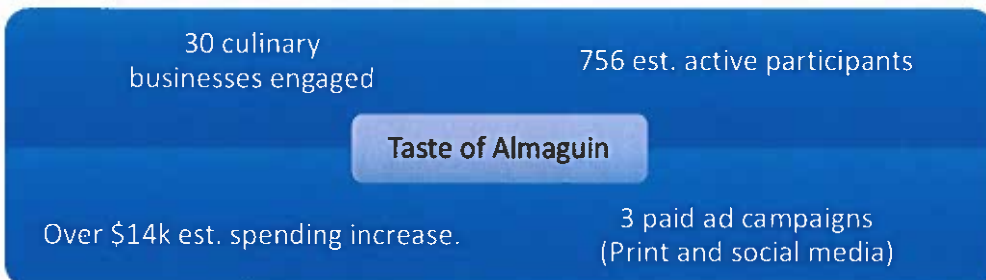



*Wrap up Almaguin Shop-Local Awareness Campaign*

The Shop in Almaguin Facebook page was used to promote shopping local for the holidays by showcasing different businesses and their unique offerings daily, doing a gift card giveaway to grow the page's following, boost engagement, and have people talk and share about their favourite businesses. The page also hosted a collaborative video that showcases different businesses across the region while talking about the reasons to support local. There were 22 unique local businesses that were mentioned by commenters.



7000+ People Reached



61 Unique Comments



85 Shares



690 Engagements

---

*FINAL KPI RESULT – 2 Campaigns Launched VS. 2 Projected;  
52 Businesses Promoted VS. 55 Projected*

---

## 5.0 Special Events & Projects

### Staycation in Almaguin

Staycation in Almaguin represented a true regional partnership effort directed towards supporting multiple sectors. The following infographic is a snapshot of the results from the Staycation in Almaguin final report. To access the full report, please contact an ACED Staff member.



## EXPERIENCES SUMMARY

Staycation in Almaguin represented a pan-regional, multi-partner response to the ongoing effects of the COVID-19 pandemic. 12,961 residents & visitors participated in experiences (live and virtual).

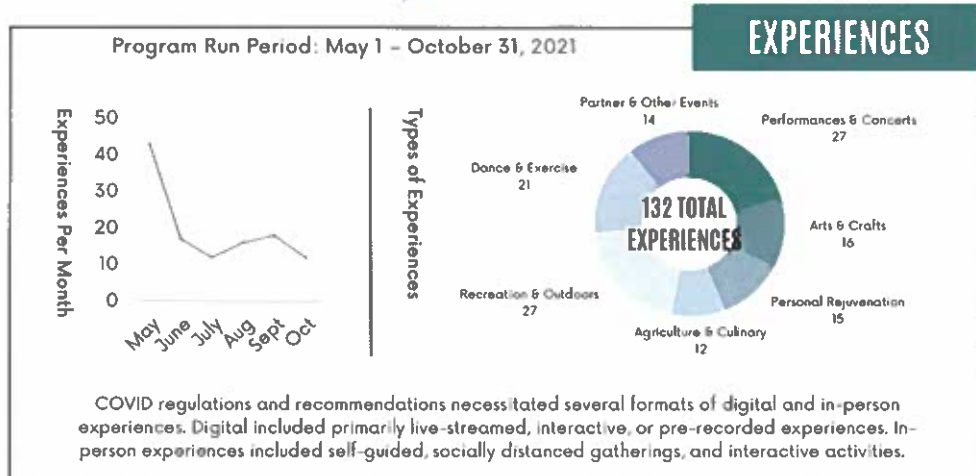

The three pillars of Staycation were

- Widespread regional collaboration
- Promoting our diverse businesses and communities
- Promoting community features, and programs

Local Investment **92%**  
Spending occurred in 96 businesses (89 in Almaguin)

Total Expenditure  
**\$58,418.45**

### Almaguin Highlands Tourism Facebook Page Audience Location:

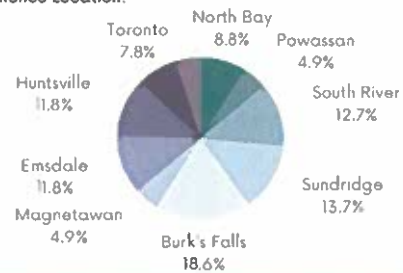



2022 ACED DEPARTMENT  
WORK PLAN



## CONTENTS

|                                                           |    |
|-----------------------------------------------------------|----|
| Introduction .....                                        | 2  |
| Definitions .....                                         | 2  |
| The Plan.....                                             | 2  |
| 1.0 Business Support and Development.....                 | 3  |
| 2.0 Community Development.....                            | 4  |
| 3.0 Economic Capacity Building .....                      | 5  |
| 4.0 Marketing and Promotion.....                          | 7  |
| 5.0 Special Events & Projects .....                       | 9  |
| Appendix A – Regional Brand Implementation Work Plan..... | 10 |
| APPENDIX B – Performance Targets .....                    | 11 |



## INTRODUCTION

The 2022 ACED Workplan has been designed as a framework that will guide the efforts of staff through 2022. As with previous years, staff will continue to work towards implementing the strategic directions set out in the various plans and studies that have been produced through collective, regional efforts. In addition to planned and recommended action items, ACED efforts will also be heavily focused on supporting the implementation of the Regional Brand Strategy as well as supporting businesses and community service organizations as they continue to experience challenges resulting from the COVID-19 pandemic, with a focus on supporting their recovery.

## DEFINITIONS

|                |                                                                      |
|----------------|----------------------------------------------------------------------|
| ACED           | Almaguin Community Economic Development                              |
| Ag Strategy    | 2020 Agricultural and Culinary Stakeholder Engagement Strategy       |
| AHCC           | Almaguin Highlands Chamber of Commerce                               |
| Brand Strategy | 2020 Almaguin Highlands Regional Brand Strategy                      |
| BR&E           | Business Retention & Expansion                                       |
| DoED           | Director of Economic Development                                     |
| ED             | Economic Development                                                 |
| EDO            | Economic Development Officer                                         |
| RBC            | Regional Brand Coordinator                                           |
| RED Plan       | 2018 Almaguin Highlands Regional Economic Development Strategic Plan |

## THE PLAN

All work plan action items have been categorized into five primary themes that represent the objectives and core functions of the ACED Board and Department. Each of these themes is intended to reinforce a specific outcome as defined under their respective headings. Specific action items for each theme have been derived from evidence-based research as referenced in the following guiding documents:

- [The 2018 RED Plan](#)
- [The 2020 Ag Strategy](#)
- [The 2021 Brand Strategy](#)
- [The 2016 BR&E Report](#)

An index of performance targets can be seen in Appendix B.



## 1.0 BUSINESS SUPPORT AND DEVELOPMENT

Business support and development encompasses all activities intended to support businesses in any capacity. This includes but is not limited to start up, expansion, general business support, online presence building, networking, and site selection.

### A. BUSINESS SUPPORT      COST: TIME/TRAVEL      TIMELINE: CORE/ONGOING

Directly supporting businesses and entrepreneurs as they pursue their goals and navigate challenges has been a core function of ACED and previous economic development initiatives for many years. In 2022, ACED Staff will work to increase the promotion of these services as well as remain available for inbound support requests and referrals from stakeholder organizations. Additional core supports include:

- i. Business directory updates (Annual).
- ii. Accommodation directory updates (Annual).
- iii. Asset inventory updates (Quarterly).
- iv. Digital Main Street Partnership (The Business Centre, as available).

### B. BR&E PROCESS      COST: TIME/TRAVEL      TIMELINE: CORE

The DoED and EDO will design and launch an ongoing Business Retention and Expansion process that will include a standard BR&E survey which will be used to identify opportunities and challenges and provide direct supports to businesses throughout the year. The BR&E process will be promoted through outreach in partnership with ED stakeholders and through direct communications and social media networks.

### C. BUSINESS SUPPORT EVENTS      COST: \$2,000      TIMELINE: BI-MONTHLY

Through partnerships with local ED stakeholders and organizations, ACED will co-host a series of business support and networking events, consistent with a social atmosphere. As COVID restrictions permit, events will be in-person to facilitate networking opportunities. Should in-person events not be possible, virtual information sessions will showcase support opportunities with partnering organizations serving Almaguin in a mini-presentation and 'Ask-Me-Anything' format to encourage open dialogue.



**D. AHCC PARTNERSHIPS**                      **COST: \$2,000**                      **TIMELINE: PROJECT SPECIFIC**

Staff will continue to work with the AHCC Board to implement their core programming and continue to build capacity throughout the region. Specific action items include:

- i. Support the implementation of an AHCC Welcome Wagon program to support awareness of, and membership within, the Chamber of Commerce while promoting ACED services.
- ii. Partner to implement the second annual Influential Women of Almaguin initiative.
- iii. Support the enhancement of the Almaguin Highlands Chamber of Commerce Community Guide and Directory per the Brand Strategy Asset Development recommendations.

**E. WIN THIS SPACE ALMAGUIN**                      **COST: \$1,000**                      **TIMELINE: Q1 & Q2**

ACED Staff will support the Village of Burk’s Falls’ win this space competition through providing direct program support to Village staff and business participants. This will include workshop support, promotional support, and other services as required. ACED will work with program partners to collect and package information, resources, and best practices that can be used by other communities in the region who wish to pursue similar initiatives in the future.

**2.0 COMMUNITY DEVELOPMENT**

Community development is broken into two main segments: working to support community and recreation-based organizations; and supporting community and recreation-based projects undertaken by municipalities and other partners.

**A. COMMUNITY PROGRAM G.R.O.**                      **COST: \$2,000**                      **TIMELINE: Q1-Q2**

ACED staff will continue to seek out and support community organizations who have experienced challenges because of the pandemic. ACED will offer direct, individualized support to organizations which will focus on assessing their needs and providing tools to support their efforts. Support offerings will include:

- i. Attending meetings and facilitate the completion of the G.R.O. workbook.
- ii. Providing access to the Almaguin Website Volunteer Portal.
- iii. Identifying opportunities for funding support and other collaborative efforts such as volunteer fairs.



**B. VILLAGE IMPRESSIONS PROGRAM      COST: TIME/TRAVEL      TIMELINE: Q2/Q3**

Through consultations with municipal stakeholders, ACED staff will finalize the community visitation and recommendations process which will focus on beautifying community centres throughout Almaguin. Where possible, ACED will lead any collaborative funding applications that align beautification efforts throughout the region with a focus on regional brand adoption.

**C. REGIONAL RECREATION SUPPORT      COST:TIME      TIMELINE: 2022**

Through the implementation of the Regional Brand Strategy, ACED will catalogue and promote regional recreation opportunities through the Almaguin Website, regional guide, and mapping recommendations. ACED will seek partnership opportunities with supportive organizations such as Discovery Routes and Explorer’s Edge to promote awareness of regional recreation assets. Additionally, and wherever possible, ACED Staff will support municipal projects that are consistent with the recommendations made in the 2018 RED Plan such as “maintain and expand recreational, sports and cultural opportunities”. Specific projects include:

- i. Work with municipal staff to catalogue and promote recreational assets through the Almaguin Website.
- ii. Support the development of experience itineraries and content and help coordinate marketing efforts to reach seasonal audiences.
- iii. Build and share a regional recreation photography and videography database.
- iv. Support the efforts of municipalities to create and improve recreation spaces.

### **3.0 ECONOMIC CAPACITY BUILDING**

Economic capacity building represents activities that are intended to increase the region’s ability to attract investment of any kind. Typically, capacity building initiatives provide less immediately tangible results; however, in many cases they provide a foundation for future activities, increase the investment readiness of the region, or otherwise position the region for growth.

**A. MUNICIPAL ENGAGEMENT      COST: TIME/TRAVEL      TIMELINE: Q1 & Q2**

Continuing with the municipal meetings from 2021, ACED staff will engage municipal staff to identify opportunities to support municipal projects and the pursuit of development related capacity building. Key areas of interest could include:





- i. Identifying economic development, recreation, and marketing related priorities.
- ii. Supporting the development of industrial and commercial properties.
- iii. Supporting staff in adopting the regional brand and encouraging marketing partnership opportunities per the Brand Strategy.

#### **B. BROADBAND DEVELOPMENT**

**COST: TIME**

**TIMELINE: CORE**

ACED staff will continue to monitor the priorities of the Ministry of Infrastructure's efforts to deploy broadband services to all homes and businesses by 2025. Additionally, staff will remain positioned to support any initiatives aimed at increasing broadband service availability, whether through pursuing funding or assisting with planning efforts undertaken by public or private sector stakeholders.

#### **C. TRANSPORTATION**

**COST: \$,2500**

**TIMELINE: Q2**

ACED will build on the 2021 efforts related to the Carpool Almaguin lots by investigating opportunities to revitalize or replace existing signage at established or new locations. ACED will additionally remain positioned to support the continued consideration and exploration of Almaguin as a stop for the Northlander Train Service.

- Staff will use existing ACED channels to promote the use of publicly maintained lots for ride sharing opportunities and safe exchange sites for private marketplace transactions (Kijiji, etc.). Staff will also continue to investigate other creative solutions to overcome transportation barriers where possible through researching best practices and supporting private sector initiatives where they exist.

#### **E. AHSS STUDENT ENGAGEMENT**

**COST: TIME**

**TIMELINE: Q2**

Building on the relationship established with the AHSS Staff and Faculty, staff will maintain their presence to support entrepreneurialism, civic engagement and participation in the longitudinal study introduced in 2021. ACED will work with community support organizations to promote and deliver programs available to students and support students in accessing programs.

Specific objectives include:

- i. Promoting and supporting engagement in the Business Centre's Summer Company program.



- ii. Continuing graduating class exit interview process to identify opportunities to retain or reattract youth.
- iii. Pursue opportunities to an established in-school presence by providing presentations regarding entrepreneurialism, volunteerism, and/or topics highlighted by any class curricula.

**4.0 MARKETING AND PROMOTION**

Marketing and promotion will encompass all activities intended to market or promote any aspect of the region. This includes website development, general tourism promotion, business joint marketing initiatives (including shop-local activities), local initiative promotion, story telling and other marketing activities. Throughout the priority areas in projects A, B, and C, staff will work to incorporate associated costs into the funding allocated to the regional brand strategy budget under the cost categories that they align with. These cost categories are identified under each specific project.

**A. BRAND STRATEGY IMPLEMENTATION                      COST: \$169,428                      TIMELINE: 2022**

**BRAND STRATEGY COST CATEGORY: ALL**

The Regional Brand Coordinator has provided a condensed Brand Strategy workplan which can be seen in Appendix A. All Brand Strategy initiatives will be supported by all ACED staff where required and funded in part by FedNor and the Ontario Ministry of Agriculture, Food and Rural Affairs.

**B. AG STRATEGY IMPLEMENTATION                      COST: \$1,703+                      TIMELINE: Q1-Q3**

**BRAND STRATEGY COST CATEGORY: Marketing Partnership & Regional Asset Development**

Based on consultations with agricultural operators throughout the region, ACED will support and/or develop the following initiatives:

- i. Host 3-4 agri-food networking and information sessions geared to introducing the Workplaces platform and identifying ways to enhance and promote local food.
- ii. Creating a Roadmap to Almaguin Food – print and digital.
- iii. Investigating the creation and distribution of farm gate signage using the marketing partnership.
- iv. Creating a dedicated agri-food/food tourism page on the Almaguin website.



- v. Producing agri-food photography and/or videography for the regional database.
- vi. Working with value chain members to populate seasonal agri-food newsletters.
- vii. Work with stakeholders to explore additional marketing and promotional efforts.

#### C. TOURISM PROMOTION

COST: TBD BY PROJECT

TIMELINE: 2022

BRAND STRATEGY COST CATEGORY: Brand Awareness & Regional Asset Development

Using the Almaguin Website and social media channels, ACED will work with tourism stakeholders throughout the region to develop content and stories related to tourism assets. Priority sectors will include arts and culture, four season recreation (paddling, hiking, cycling snowmobiling, ATVing, golf, entertainment, etc.). Staff will engage the support of organizations such as Discovery Routes, Explorers' Edge and Northern Ontario Tourism to promote content, stories and other marketing collateral to draw tourism to the area. Through all efforts, staff will work to promote multiple businesses, natural features, local accommodations and easy-to-access experiences for visitors and residents.

- i. Partner with local businesses to create experience itineraries that promote travel and spending throughout the region.
- ii. Engage multiple organizations such as ATV clubs, Snowmobile Clubs, the Almaguin Highlands Arts Council, and others to ensure accuracy and volume of offerings.
- iii. Produce photography and videography of experiences and tourism products.
- iv. Utilize marketing dollars to push content to southern markets like past Explorer's Edge partnerships.

#### D. SHOP IN ALMAGUIN CAMPAIGNS

COST: \$1000

TIMELINE: SPRING/FALL

Staff will continue to promote shopping and dining locally through creating shop local initiatives and awareness campaigns by partnering with and promoting multiple local businesses.



## 5.0 SPECIAL EVENTS & PROJECTS

Special Events and Projects are geared to draw enhanced attention to regional features and assets. 2022 will be geared both for event hosting as well as promoting safe and accessible events occurring throughout the region.

### A. RED GALA

**COST: \$2,000**

**TIMELINE: Q3**

Staff will seek to re-establish the RED Gala as an economic development showcase event focused on bringing together stakeholders in regional economic development, provided gathering limitations do not impede mass gathering events in the Fall of 2022. Specific focus areas include promoting the Almaguin brand, celebrating regional economic and community development success stories, and networking. Staff will pursue the financial, planning and marketing assistance of regional support organizations to host the event.

APPENDIX A – REGIONAL BRAND IMPLEMENTATION WORK PLAN



**REGIONAL BRAND COORDINATOR  
2022 WORK PLAN**

**BRAND AWARENESS**



Create and gather content for advertising



Create regional and community signage



Create social strategy & develop content



Create social media campaigns

**REGIONAL BRAND HUB**

**Social Media:**

- Consolidate social media pages into one regional page
- Integrate regional branding across social media platforms
- Establish and maintain one social media account on Facebook, Instagram and LinkedIn

**Website Development:**

- Select web developer to build online platform and integrate economic development and tourism websites into one portal
- Work with partners to gather required content and information
- Create copy that resonates with identified audience groups for each component of portal

**BRAND ADOPTION**

**Wayfinding and Marketing Partnership Program:**

- Establish an annual operating budget
- Establish program terms to guide the overall process
- Develop application forms and agreement templates
- Create a Wayfinding Strategy to guide signage design and installation
- Establish an application review committee

**Training and Support:**

- Support Municipal staff to implement brand
- Develop a training video
- Design and print tangible assets such as USBs, decals, and QR codes
- Recruit businesses and community organizations to become brand ambassadors
- Host 'open house' sessions to promote the ambassador program

**REGIONAL ASSET DEVELOPMENT**

- Produce and Establish a central media database to host media assets such as videography and photography
- Creation of Tradeshow booth materials, and brand publications
- Create and distribute regional publications

- Support enhancement of the regional guide for distribution
- Produce regional maps consistent with ACED priorities



**APPENDIX B – PERFORMANCE TARGETS**

| Work Plan Item   KPI Description      | 2022 Target | 2021 Result | FedNor Target           |
|---------------------------------------|-------------|-------------|-------------------------|
| <b>Section 1 - Business Support</b>   |             |             |                         |
| <b>A. Core Business Support</b>       |             |             |                         |
| <b>Businesses Supported (Unique)</b>  | 75          | 68          |                         |
| <b>Jobs Created</b>                   | 16          | 11          | 16 Per Year             |
| <b>Jobs Retained</b>                  | 16          | 34          | 16 Per Year             |
| <b>B. BR&amp;E By Industry</b>        |             |             |                         |
| <b>Total Interviews</b>               | 30          | 10          |                         |
| <b>C. Digital Main Street Support</b> |             |             |                         |
| <b>Businesses Supported</b>           | 40          | 45          |                         |
| <b>D. Business Support Events</b>     |             |             |                         |
| <b>Events Hosted</b>                  | 5           | 3           |                         |
| <b>Business Attendees</b>             | 150         | 25          | 150/Year                |
| <b>E. AHCC Partnerships</b>           |             |             |                         |
| <b>Membership Increase</b>            | 10%         | N/A         | 10% / Year              |
| <b>F. Win This Space Almaguin</b>     |             |             |                         |
| <b>Locations Established</b>          | 2           | 0           |                         |
| <b>Entrepreneur Participants</b>      | 5           | 0           |                         |
| <b>2.0 Community Development</b>      |             |             |                         |
| <b>A. Community Program G.R.O</b>     |             |             |                         |
| <b>Organizations Supported</b>        | 5           | N/A         |                         |
| <b>Volunteer Positions Marketed</b>   | 15          | N/A         |                         |
| <b>B. Village Assessment Program</b>  |             |             |                         |
| <b>Villages Assessed</b>              | 2           | N/A         |                         |
| <b>C. Regional Recreation</b>         |             |             | Rec Master Plan Created |
| <b>Experiences Promoted</b>           | 10          | N/A         | N/A                     |
| <b>Partnerships Developed</b>         | 6           | N/A         |                         |
| <b>3.0 Economic Capacity Building</b> |             |             |                         |
| <b>A. Municipal Engagement</b>        |             | N/A         |                         |
| <b>Municipalities Engaged</b>         | 3           | N/A         |                         |
| <b>B. Broadband Development</b>       |             |             | 3.3% Coverage / Year    |
| <b>Projects Supported</b>             | T.B.D.      | 2           |                         |
| <b>Advocacy Efforts</b>               | 14          | 4           |                         |



| Work Plan Item   KPI Description         | 2022 Target | 2021 Result | FedNor Target |
|------------------------------------------|-------------|-------------|---------------|
| <b>C. Transportation Development</b>     |             |             |               |
| <b>Projects Undertaken</b>               | 1           | 1           |               |
| <b>E. AHSS Student Engagement</b>        |             |             |               |
| <b>Initiatives Launched</b>              | 2           | 1           |               |
|                                          |             |             |               |
| <b>4.0 Marketing &amp; Promotion</b>     |             |             |               |
| <b>A. Brand Strategy Implementation</b>  |             |             |               |
| <b>Regional Partnerships Established</b> | 5           | N/A         |               |
| <b>Brand Ambassadors Onboarded</b>       | 15          | N/A         |               |
| <b>Marketing Partnership Projects</b>    | 5           | N/A         |               |
| <b>Key Brand Assets Created</b>          | 10          | N/A         |               |
| <b>Brand Events/Training Hosted</b>      | 5           | N/A         |               |
|                                          |             |             |               |
| <b>B. Ag. Strategy Implementation</b>    |             |             |               |
| <b>Initiatives Undertaken</b>            | 7           | 6           |               |
| <b>Business included / promoted</b>      | 25          |             |               |
| <b>C. Tourism Promotion</b>              |             |             |               |
| <b>Partnerships Developed</b>            |             | 1           |               |
| <b>Itineraries Dev.</b>                  | 2           | 5           |               |
| <b>D. Shop in Almaguin Campaigns</b>     |             |             |               |
| <b>Campaigns Launched</b>                | 2           | 2           |               |
| <b>Business Promoted</b>                 | 55          | 52          | 50/Year       |
|                                          |             |             |               |
| <b>5.0 Special Events &amp; Projects</b> |             |             |               |
| <b>B. Red Gala</b>                       |             |             |               |
| <b>Total Attendees</b>                   | 100         | N/A         |               |

**2022 Budget Sheets - Actuals as of December 31st, 2021**  
**Regional Economic Development**  
**Operating Budget - Page 1**

| GL Number  | Description                                         | 2021 Actual           | 2021 Budgeted      | 2022 Department Estimate | Notes                                                           |
|------------|-----------------------------------------------------|-----------------------|--------------------|--------------------------|-----------------------------------------------------------------|
|            | <b>Revenues</b>                                     |                       |                    |                          |                                                                 |
| 13-807-000 | ACED surplus                                        | \$0.00                | \$0.00             | \$0.00                   |                                                                 |
| 15-370-000 | <b>Municipal &amp; Chamber Contributions</b>        |                       |                    |                          |                                                                 |
|            | Armour                                              | (\$7,500.00)          | (\$10,000)         | (\$10,000)               |                                                                 |
|            | Burk's Falls                                        | (\$7,500.00)          | (\$10,000)         | (\$10,000)               |                                                                 |
|            | Joly                                                | (\$3,750.00)          | (\$5,000)          | (\$5,000)                |                                                                 |
|            | Magnetawan                                          | (\$7,500.00)          | (\$10,000)         | (\$7,500)                | Note 1: Contribution for period ending Sept. 30, 2021.          |
|            | Perry                                               | (\$7,500.00)          | (\$10,000)         | (\$10,000)               |                                                                 |
|            | Powassan                                            | (\$7,500.00)          | (\$10,000)         | (\$10,000)               |                                                                 |
|            | Ryerson                                             | (\$7,500.00)          | (\$10,000)         | (\$10,000)               |                                                                 |
|            | South River                                         | (\$7,500.00)          | (\$10,000)         | (\$10,000)               |                                                                 |
|            | Strong                                              | (\$7,500.00)          | (\$10,000)         | (\$10,000)               |                                                                 |
|            | Sundridge                                           | (\$7,500.00)          | (\$10,000)         | (\$10,000)               |                                                                 |
|            | Chamber of Commerce                                 | (\$5,000.00)          | (\$10,000)         | (\$10,000)               |                                                                 |
|            | Total Municipal & Chamber Contri.                   | (\$76,250.00)         | (\$105,000)        | (\$102,500)              |                                                                 |
| 15-370-005 | User fees - Almaguin Harvest Spin                   | \$0.00                | (\$10,000)         | \$0                      |                                                                 |
| 15-370-008 | Staycation contributions                            | (\$15,250.00)         | \$0                | \$0                      |                                                                 |
| 15-371-000 | CIINO Funding                                       | (\$94,127.00)         | (\$129,500)        | (\$162,000)              | Note 2: Represents 84.27% of total salaries + 28% in benefits.  |
| 15-371-002 | FedNor - Harvest Spin/Staycation                    | (\$1,901.00)          | (\$19,717)         | \$0                      |                                                                 |
| 15-371-003 | FedNor - Implement Brand Strategy                   | \$0.00                | (\$40,000)         | (\$86,000)               | Note 3: 36.17% of \$239,000 (Shared in 15-372-003 & 15-370-000) |
| 15-371-005 | OBIAA Funding - Intern                              | (\$4,897.21)          | (\$4,850)          | \$0                      |                                                                 |
| 15-371-007 | NECO - Staycation Program                           | (\$10,000.00)         | \$0                | \$0                      | Note 4: Applied for and disbursed in 2021 (non-budgeted).       |
| 15-371-008 | NECO - Regional Relief & Recovery                   | \$0.00                | \$0                | \$0                      | Note 5: Non active. Applied for and disbursed in 2020.          |
| 15-372-000 | NOHFC Funding - Intern                              | (\$22,883.14)         | (\$7,280)          | \$0                      | Note 6: Internship closed Sept. 30, 2021.                       |
| 15-372-001 | NOHFC - Almaguin Harvest Spin                       | \$0.00                | (\$15,000)         | \$0                      | Note 7: Application not submitted in favour of Reconnect.       |
| 15-372-002 | NOHFC - Almaguin Brand Strategy                     | \$0.00                | \$0                | \$0                      | Note 8: Final payment retroactively paid in 2020.               |
| 15-372-003 | RED - Implement Brand Strategy                      | \$0.00                | (\$60,000)         | (\$119,500)              | Note 9: 50% of \$239,000 (shared in 15-371-002 & 15-370-000).   |
| 15-373-001 | MHSTIC - Reconnect Grant                            | (\$13,160.00)         | \$0                | \$0                      |                                                                 |
|            |                                                     |                       |                    |                          |                                                                 |
|            | <b>Total Regional Economic Development revenues</b> | <b>(\$238,468.35)</b> | <b>(\$391,347)</b> | <b>(\$470,000)</b>       |                                                                 |



**2022 Budget Sheets - Actuals as of December 31st, 2021**  
**Regional Economic Development**  
**Operating Budget - Page 2**

| GL Number  | Description                                             | 2021 Actual          | 2021 Budgeted    | 2022 Department Estimate |                                                             |
|------------|---------------------------------------------------------|----------------------|------------------|--------------------------|-------------------------------------------------------------|
|            | <b>Expenditures</b>                                     |                      |                  |                          |                                                             |
| 16-801-000 | Salaries & Benefits                                     | \$157,887.86         | \$210,050        | \$259,869                | Note 10: Reflects salaries for 3 employees for a full year. |
| 16-804-001 | Office Supplies                                         | \$2,252.06           | \$3,000          | \$3,000                  |                                                             |
| 16-804-005 | Audit & Accountant Fees                                 | \$0.00               | \$4,000          | \$4,500                  |                                                             |
| 16-804-007 | Legal Fees                                              | \$0.00               | \$0              | \$0                      |                                                             |
| 16-804-010 | Advertising & Promotion                                 | \$3,544.79           | \$3,550          | \$4,500                  |                                                             |
| 16-804-020 | Telephone                                               | \$1,435.45           | \$2,500          | \$2,500                  |                                                             |
| 16-804-025 | Website                                                 | \$237.75             | \$2,500          | \$2,000                  |                                                             |
| 16-804-030 | Events & Seminars                                       | \$1,086.75           | \$4,000          | \$4,000                  |                                                             |
| 16-804-040 | Training & Workshops                                    | \$2,839.39           | \$4,000          | \$4,000                  |                                                             |
| 16-804-050 | Travel                                                  | \$2,068.69           | \$6,000          | \$6,000                  |                                                             |
| 16-804-060 | Office Rental                                           | \$0.00               | \$0              | \$0                      |                                                             |
| 16-804-062 | Regional Relief & Recovery Program                      | \$0.00               | \$0              | \$0                      |                                                             |
| 16-804-063 | Almaguin Harvest Spin                                   | \$0.00               | \$45,000         | \$0                      |                                                             |
| 16-804-064 | Almaguin Brand Strategy                                 | \$0.00               | \$0              | \$0                      |                                                             |
| 16-804-065 | Regional Projects                                       | \$6,452.13           | \$26,747         | \$10,203                 | Note 11: May change based on any 2021 surplus.              |
| 16-804-066 | Implement Almaguin Brand Strategy                       | \$0.00               | \$80,000         | \$169,428                | Note 12: \$239,000 less salaries & benefits in 16-801-000.  |
| 16-804-070 | Transfer to EDC Reserve                                 | \$0.00               | \$0              | \$0                      |                                                             |
| 16-804-071 | Staycation Program                                      | \$32,086.43          | \$0              | \$0                      |                                                             |
|            | <b>Total Regional Economic Development expenditures</b> | <b>\$209,891.30</b>  | <b>\$391,347</b> | <b>\$470,000</b>         |                                                             |
|            |                                                         |                      |                  |                          |                                                             |
|            | <b>Total Regional Economic Development</b>              | <b>(\$28,577.05)</b> | <b>\$0</b>       | <b>\$0</b>               |                                                             |
|            |                                                         |                      |                  |                          |                                                             |

| GL Number  | Expenditures                               | Item Cost          | Budget AMT |
|------------|--------------------------------------------|--------------------|------------|
| 16-804-001 | Office Supplies                            |                    | \$3,000    |
|            | Office 365 (5 user)                        | \$ 100             |            |
|            | Kaspersky AV (5 user)                      | \$ 100             |            |
|            | Survey Monkey                              | \$ 460             |            |
|            | Zoom Account                               | \$ 280             |            |
|            | Adobe Creative Cloud                       | \$ 985             |            |
|            | Misc Supplies                              | \$ 1,075           |            |
|            | <b>Total</b>                               | <b>\$ 3,000</b>    |            |
| 16-804-010 | Advertising & Promotion (General)          |                    | \$4,500    |
| 16-804-025 | Website                                    |                    | \$2,000    |
|            | Domain, hosting & email fees (2 sites)     | \$ 600             |            |
|            | Website Contingency                        | \$ 1,400           |            |
|            | <b>Total</b>                               | <b>\$ 2,000</b>    |            |
| 16-804-030 | Events & Seminars                          |                    | \$4,000    |
|            | Business Support Events                    | \$ 2,000.00        |            |
|            | AHCC Partnerships                          | \$ 2,000.00        |            |
|            | <b>Total</b>                               | <b>\$ 4,000.00</b> |            |
| 16-804-040 | Training & Workshops                       |                    | \$4,000    |
|            | EDCO & EDAC memberships                    | \$ 1,500           |            |
|            | Professional Development                   | \$ 1,000           |            |
|            | General Admission Fees(Conferences, etc)   | \$ 1,500           |            |
|            | <b>Total</b>                               | <b>\$ 4,000</b>    |            |
| 16-804-064 | Almaguin Brand Strategy                    |                    | \$169,428  |
|            | Almaguin Website Development               | \$ 15,000          |            |
|            | Third Party Implementation Support         | \$ 20,000          |            |
|            | Brand Ambassador Programming               | \$ 10,000          |            |
|            | Regional Guide Creation, Mapping and Print | \$ 20,000          |            |
|            | Photography and Videography                | \$ 20,000          |            |
|            | Brand Adoption & Awareness                 | \$ 20,000          |            |
|            | Marketing Partnership Program              | \$ 64,428          |            |
|            | <b>Total</b>                               | <b>\$ 169,428</b>  |            |
| 16-804-065 | Regional Projects                          |                    | \$10,203   |
|            | Project 1E - Win this Space                | \$ 1,000           |            |
|            | Project 2A - Community G.R.O.              | \$ 2,000           |            |
|            | Project 3C - Carpool Almaguin              | \$ 2,500           |            |
|            | Project 4B - Ag Streategy                  | \$ 1,703           |            |
|            | Project 4D - Shop in Almaguin              | \$ 1,000           |            |
|            | Project 5A - RED Gala                      | \$ 2,000           |            |
|            | <b>Total</b>                               | <b>\$ 10,203</b>   |            |



**Magnetawan Community Development Committee (MCDC)  
Meeting Minutes  
February 15, 2022**

The meeting of the Magnetawan Community Development Committee was held on Tuesday February 15 at 2:30 pm with the following present:

**Committee members in attendance:**

Cathy Loree Bulych  
Councillor John Hetherington  
Marilyn Raaflaub (virtually)  
Merik Szabunio (virtually)  
Vice Chair Diane Szabunio (virtually)

**Regrets:**

Dan Raaflaub  
Daniel Wilson

**Staff members in attendance:**

Deputy Clerk Laura Brandt (Secretary)

**Opening Business**

Committee Member Cathy Loree Bulych assumed the position of Chair.

**1.1 Call to Order**

Meeting was called to order at 2:30 pm.

**1.2 Adoption of the Agenda**

*RESOLUTION 2022-01 Hetherington-D. Szabunio*

*BE IT RESOLVED THAT the Magnetawan Community Development Committee adopts the agenda as presented and circulated.*

*Carried.*

### **1.3 Appoint Vice Chair**

*RESOLUTION 2022-02 M. Szabunio-Hetherington*

*WHEREAS the Municipal Procedural By-law 2020-29, outlines that Committees of Council must appoint a Vice Chair;*

*AND WHEREAS the Magnetawan Community Development Committee is an active committee or board of Council;*

*THEREFORE BE IT RESOLVED THAT the Magnetawan Community Development Committee appoints Diane Szabunio as vice chair for the 2022 and 2023 calendar year.*

*Carried.*

### **1.4 Disclosure of Pecuniary Interest**

It was stated that should anyone have a disclosure of pecuniary interest that they could declare the nature thereof now or any time during the meeting.

### **1.5 Adoption of Previous Minutes**

*RESOLUTION 2022-03 Hetherington-M. Szabunio*

*BE IT RESOLVED THAT the Magnetawan Community Development Committee adopts the minutes from the meeting of October 12, 2021.*

*Carried.*

### **Guest Speaker**

#### **Barb Stewart, Magnetawan Horticultural Society Garden Tour Open House**

The Secretary introduced Barb Stewart to the Committee. Committee member Cathy Loree Bulych is also the Treasurer for the Magnetawan Horticultural Society. This year Canada Wide is the Year of the Garden. The Committee discussed that at the last meeting of Council that a Proclamation was made for the Municipality declaring 2022 the Year of the Garden. It was also discussed how the Committee could support the Horticultural Society on the Ribbon Cutting Ceremony Day June 18, 2022, as the Society will have various events that day including a ribbon cutting ceremony at the community gardens and a plant sale. The Committee discussed having a scavenger hunt highlighting the event as well as many focal points located within the Municipality. Due to lack of volunteers to man stations and COVID-19 the Committee discussed having a virtual scavenger hunt that can be posted the day of with participants sending their completed scavenger hunt electronically by a designated timed deadline. The Committee believes that they can get creative with the riddles and have participants take selfies with the answer to the riddles highlighting some of our great landmarks within our Municipality.

### **Items Brought Forward**

#### **2.1 Verbal Update Current Recreational Programming under COVID-19 Protocols**

The Secretary advised the Committee that currently the Nordic Pole Walking Group has started back up running Mondays and Fridays. As well Pickleball will start back up February 22nd and an additional evening time has been added. Additionally, Fitness Classes will be starting up at the end of February Monday and Thursday evenings. The Monday Cardio classes have been paid for by the Municipality and Thursday's Yoga classes will be paid by participants. It has been announced that some restrictions will be lifted this Thursday February 17<sup>th</sup> as well as proof of vaccination potentially to be lifted March 1<sup>st</sup>.

## **2.2 Update Public Mural Heritage Centre Museum**

The Secretary updated the Committee that the Mural has been completed and that there has been a lot of positive feedback on social media. As well a follow up article about the Mural was featured in the local newspaper.

## **2.3 Update Outcome of Magnetawan Halloween Contests**

The Secretary advised the Committee that the Halloween contests were successful and well received by residents. Judging of the entries was conducted by the CAO/Clerk and Secretary. Pictures of the entries have been included in the Agenda Package.

## **2.4 Verbal Update Dinner and a Drive-in Movie Event**

The Secretary advised the Committee that the public call for pictures of attendees at the Event did not garnish any response. As well the Secretary has applied for a grant to help with the cost of an event in 2022 along with including 50% of the cost in the 2022 draft budget. The movie company has been tentatively booked and the event moving forward depends on the approval of the budget and approval of grant funding.

## **2.5 Verbal Update Remembrance Day**

The Secretary advised the Committee that the Legion was contacted regarding the Remembrance Day Ceremonies and the Legion declined having an event/luncheon inside the Community Centre.

## **2.6 Verbal Update Projector, Screen, Outdoor Sound System**

The Secretary advised the Committee that the Projector and Screen has been located. The screen is a smaller screen, and the projector is used for Council. It is not the best quality to play movies on and is smaller in nature. There is no outdoor sound system but there are extra speakers like the ones used on the Community Centre.

## **2.7 Update Community Rocksnake Project**

The Secretary advised the Committee that the rock snake project has been completed and installed. It has gained much popularity on social media platforms and the project was featured in the local newspaper. There will be a rocksnake painting table implemented at the Heritage Museum Centre this summer. The Secretary also advised the Committee that a member of the MCCB brought forth an idea to have a rocksnake naming contest. The Committee discussed having residents email in name suggestions and then having all the names entered into a survey monkey for residents to name our rocksnake starting with the letter 'M'.

## **2.8 Magnetawan Christmas Tree Lighting**

The Secretary advised the Committee that the Christmas Tree Lighting was very successful. The new star was purchased and successfully installed along with the tree being restrung. Due to the COVID restrictions sleigh rides and Santa were unable to be included in the event. The Magnetawan Library supplied refreshment and treats, the Fire Department manned the fire pit, the new local Pastor said an opening prayer and led the carols. As well this year attendees were asked to bring a donation of a new toy or non-perishable food item for the Magnetawan Lions' Basket.

## **New Business**

### **3.1 Family Day Event**

Due to the COVID-19 restrictions a Family Day Event was not planned for 2022.

### **3.2 The Great Northern Ontario Roadshow**

The Secretary advised the Committee that Science North had contacted Almaguin Community Economic Development (ACED) Committee in regard to having the Great Northern Ontario Roadshow come to our Municipality and surrounding communities. The show is currently booked for Friday March 18, 2022, from 12 pm-4 pm. The show will showcase what happens in a car's engine on a trip to the store. Science North thinks that they will be able to have two performances. As well the Municipality has invited seven community groups to set up a table free of charge. This will be a good opportunity for community groups to network, bring awareness to what they do in the community and canvas for volunteers. So far four out of the seven groups have confirmed their attendance. The three other community groups are bringing the event back to their committees and will let the Secretary know if they will be in attendance.

### **3.3 Outcome of Museum Assistance Program, Reopening Fund for Heritage Organizations**

The Secretary advised the Committee that the Municipality was successful in their application for funding in the amount of \$5,000 and that the monies have been allocated towards another public art installation.

### **3.4 Budget Items Presented to Council January 19, 2022**

*RESOLUTION 2022-04 Raafloob-Hetherington*

*BE IT RESOLVED THAT the Magnetawan Community Development Committee receives the correspondence Budget Items Presented to Council January 19, 2022 for information purposes only. Carried.*

## **Adjournment**

### **4.1 Adjournment**

*RESOLUTION 2022-05 D. Szabunio-Hetherington*

*BE IT RESOLVED THAT the Magnetawan Community Development Committee adjourns this meeting at 3:35 pm to meet again on Tuesday March 22, 2022 at 2:30 pm or at the call of the Chair. Carried.*

**Approved by:**

---

Chair

---

Secretary



**Magnetawan Community Centre Board (MCCB)**

**Meeting Minutes**

**Wednesday February 16, 2022**

**9:00 am**

**Magnetawan Community Centre  
4304 Highway 520, Magnetawan**

**Committee members in attendance:**

Vice Chair Garfield Robertson  
Councillor Brad Kneller  
Harvey Sohm  
Maria Dunnett  
Mark Langford

**Regrets:**

Chair Garry Johnston

**Staff members in attendance:**

Deputy Clerk Laura Brandt (Secretary)  
Parks and Maintenance Manager Steve Robinson

**OPENING BUSINESS**

Vice Chair Garfield Robertson assumed the position of Chair

**1.1 Call to order**

The meeting was called to order at 9:00 AM

**1.2 Adoption of the Agenda**

*RESOLUTION 2022-01 Kneller-Dunnett*

*BE IT RESOLVED THAT the Magnetawan Community Centre Board adopts the agenda for this regular meeting of February 16, 2022.*

*Carried.*

**1.3 Disclosure of Pecuniary Interest**

Chair Robinson stated that should anyone have a disclosure of pecuniary interest that they could declare the nature thereof now or at any time during the meeting.

**1.4 Adoption of the meeting minutes from previous meeting**

*RESOLUTION 2022-02 Dunnnett-Kneller*

*BE IT RESOLVED THAT the Magnetawan Community Centre Board adopts the minutes from the committee meeting of Wednesday December 08, 2021 as copied and circulated.*

*Carried.*

**Items Brought Forward**

**2.1 Capital Budget Items Presented to Council January 19, 2022**

*RESOLUTION 2022-03 Langford-Sohm*

*BE IT RESOLVED THAT the Magnetawan Community Centre Board receives the correspondence Capital Budget Items Presented to Council January 19, 2022 for information purposes only.*

*Carried.*

**2.2 Verbal Update Roof Magnetawan Community Centre**

The Secretary advised the Committee that currently the Engineer is preparing the tender for the repairs for the community centre roof. Frank (engineer) will be acting on behalf of the Municipality as the project manager and once the tender is drafted it will be posted on the Municipal website as well as Biddingo.

**2.3 Verbal Update Grants Outcome and Potential Grant Funding**

The Secretary advised the Committee that the Municipality was unsuccessful in obtaining grant funding under the Canada Community Revitalization Grant. Additional grant funding has been applied for under the Northern Ontario Heritage Fund Corporation (NOHFC) program for the replacement of the outdoor rink boards and community centre roof. If funding is denied under the NOHFC the new grant funding Northern Ontario Resource Development Support (NORDS) could also be utilized for the repairs to the outdoor rink. There is also \$85,000 left remaining from the ICIP grant funding allocated towards the repairs of the community centre roof.

**2.4 Verbal Update Signs/Art Murals in Municipal Parking Lot**

Committee Member Brad Kneller advised the committee that the Magnetawan Agricultural Society has not had a meeting to discuss the signs/murals located in the municipal parking lot due to the COVID-19 restrictions. This matter will be brought forth at their next regular meeting.

**2.5 Verbal Update COVID-19 Protocols**

The Secretary advised the Committee that COVID-19 restrictions will again be changing as of February 17, 2022. Meeting and event spaces can open to full capacity where proof of vaccination is required.



**2.6 Discussion on Magnetawan Community Centre Floor**

The Secretary advised the Committee that if the community centre floor is replaced that it should be completed after the roof is repaired. This is to ensure that any of the roof damage or leaking has not affected the flooring by leaking down underneath the concrete. These repairs will need to be included in the 2023 Draft Budget. At this time Council is aware that the floor may need to be replaced as all committee meeting minutes are included in Council agenda packages.

**Adjournment**

**3.1 Confirm the Proceedings of Committee And Adjourn**

*RESOLUTION 2022-04 Langford-Sohm*

*BE IT RESOLVED THAT the Magnetawan Community Centre Board adjourns this meeting at 9:25 am to meet again on Wednesday April 20, 2022 at 9:00 am or the call of the chair. Carried.*

Approved by:

\_\_\_\_\_

Chair

\_\_\_\_\_

Secretary

February 08, 2022

SENT ELECTRONICALLY

Ms. Kerstin Vroom  
Chief Administrative Officer/Clerk  
Municipality of Magnetawan  
4304 HWY 520  
P.O. Box 70  
Magnetawan, ON P0A 1P0

Dear Ms. Vroom:

**Re: 2022 Municipal Levy**

Your **2022 Municipal Levy Information Package** is attached. The 2022 cost-shared budget was prepared based on the 2021 provincially approved funding including provincial mitigation funding for 2021, with an increase of 3.28% in the levy.

The mitigation funding from the Province covers the additional municipal cost due to the change in the cost-sharing formula to 30 municipal / 70 provincial. This change would have resulted in a 42% increase in the levy. The Province provided this transition funding to eliminate the 2022 increase for municipalities. It also covers the reduction to the base funding of \$369,710 that was also introduced at that time.

There is no indication at this time that there will be further transitional funding in 2023, so it would be prudent for municipalities to plan for an approximate 50% increase in 2023 on a similar shareable base of \$17,056,938.

The years 2020 and 2021 were extraordinary ones for public health, and uncertainty persists in 2022, as the fight against COVID-19 continues. Understandably, the pandemic has interrupted discussions with the Province about public health modernization, so no new information is available on this topic.

It is more important than ever for the Health Unit to stay focused on our mission “to foster healthy living within our communities by preventing illness, promoting healthy choices, and providing trusted support and information”. This year’s budget allows this important work to continue at the current level. In 2021, the Health Unit received approximately \$4.3 Million in COVID funding by the province. In 2022, a similar request will be made for 100% provincial funding to cover the costs of COVID-19 that cannot be funded through cost-shared mandatory funding.

.../2

In accordance with the Board of Health Municipal Reserve policy, B-F-007, municipalities will be updated on the 2021 year-end status of the municipal reserve following the audit process in April. The reserve balance at November 30, 2021, was \$1,792,020.

To learn more about your public health unit, COVID-19, and other public health activities and reports, refer to the North Bay Parry Sound District Health Unit website at [www.myhealthunit.ca](http://www.myhealthunit.ca). The website is completely searchable and contains information on a wide range of health topics.

The following information is attached:

- Appendix A 2022 Levy Payment Schedule
- Appendix B 2022 Board of Health Approved Budget Summary Sheet
- Appendix C Municipal Levy & Population Comparison for 2021/2022

Please do not hesitate to contact Isabel Churcher, Executive Director, Finance, at (705) 499-6016, if you have any questions.

Yours truly,



Nancy Jacko  
Chairperson, Board of Health

Enclosures (3)

Copy to: Isabel Churcher, Executive Director, Finance  
Dr. Jim Chirico, Medical Officer of Health/Executive Officer  
Board of Health



February 10, 2022

Municipality of Magnetawan  
 4304 HWY 520  
 P.O. Box 70  
 Magnetawan, ON P0A 1P0

**2022 LEVY  
 PAYMENT SCHEDULE**

**2022 Annual Levy \$43,294.88**

| Monthly Payment Schedule effective January 1, 2022 | Amount             |
|----------------------------------------------------|--------------------|
| January 1                                          | 3,493.19           |
| February 1                                         | 3,493.19           |
| March 1                                            | 3,630.85           |
| April 1                                            | 3,630.85           |
| May 1                                              | 3,630.85           |
| June 1                                             | 3,630.85           |
| July 1                                             | 3,630.85           |
| August 1                                           | 3,630.85           |
| September 1                                        | 3,630.85           |
| October 1                                          | 3,630.85           |
| November 1                                         | 3,630.85           |
| December 1                                         | 3,630.85           |
| <b>Total</b>                                       | <b>\$43,294.88</b> |

Levy based on population of: 1,167

Per Capita Rate: \$37.10

**Due Date: The first day of every month**  
 Interest is charged at 1.25% per month on outstanding balances.

**Please remit to: North Bay Parry Sound District Health Unit  
 Attention: Finance Department  
 345 Oak St W  
 North Bay, ON P1B 2T2**

**Or Direct Deposit to: Account # 03442 003 1287499**

*Your lifetime partner in healthy living.*  
*Votre partenaire à vie pour vivre en santé.*  
 myhealthunit.ca

Call Toll Free: 1-800-563-2808

|                                                 |                                                         |
|-------------------------------------------------|---------------------------------------------------------|
| 📍 345 Oak Street West,<br>North Bay, ON P1B 2T2 | 📍 70 Joseph Street, Unit 302<br>Parry Sound, ON P2A 2G5 |
| ☎ 705-474-1400                                  | ☎ 705-746-5801                                          |
| 📠 705-474-8252                                  | 📠 705-746-2711                                          |

## 2022 Board of Health Public Health Budget

### Table I Budget Summary Sheet

Appendix B  
Approved BOH January 26, 2022

| Budget Summary                                      | Reconciled Budget 2021 | Forecast 2021     | Budget 2022       | Notes    |
|-----------------------------------------------------|------------------------|-------------------|-------------------|----------|
| <b>Total Expenses*</b>                              | <b>21,515,201</b>      | <b>25,659,465</b> | <b>22,309,044</b> | <b>1</b> |
| Less Program Revenues*                              | 412,325                | 434,569           | 359,800           | 2        |
| <b>Net Expenses</b>                                 | <b>21,102,876</b>      | <b>25,224,896</b> | <b>21,949,244</b> |          |
| Less: 100% Funding and One-Time Funding and Grants* | 4,434,309              | 8,556,329         | 4,892,306         | 3        |
| <b>Total Shareable Base (see breakdown below)</b>   | <b>16,668,567</b>      | <b>16,668,567</b> | <b>17,056,938</b> |          |
| <b>Mitigation Funding for Base Reduction</b>        | <b>369,710</b>         | <b>369,710</b>    | <b>369,710</b>    |          |
| <b>Net Shareable Base</b>                           | <b>16,298,857</b>      | <b>16,298,857</b> | <b>16,687,228</b> |          |
| Ministry of Health (70% as of 2020)                 | 11,409,200             | 11,409,200        | 11,681,060        |          |
| Municipal Share (30% as of 2020)                    | 4,889,657              | 4,889,657         | 5,006,168         |          |
| Less: One Time Funding - Public Health Mitigation   | -1,422,690             | -1,422,690        | -1,422,690        |          |
| Plus: 100% Municipal - Adult Dental                 | 80,780                 | 80,780            | 80,780            |          |
| Net Municipal Levy                                  | 3,547,747              | 3,547,747         | 3,664,258         |          |
| Per Capita Municipal Population                     | 98,769                 | 98,769            | 98,769            | 4        |
| Per Capita Rate                                     | 35.92                  | 35.92             | 37.10             | 5        |

#### Notes for Budget Summary

- 1 Total expenses includes the cost of all Health Unit programs and services.
- 2 Program revenues are generated through payments from the public or the government on a fee-for-service basis.
- 3 The forecast for 2021 includes all usual 100% funded programs from multiple sources. This year is much higher as it includes all COVID-19 general and vaccination funding from the Ministry of Health.
- 4 As per the *Health Protection and Promotion Act*, R.S.O. 1990, c. H.7, O. Reg. 489-97 Allocation of Board of Health Expenses, populations are based on current (2018) Municipal Property Assessment Corporation (MPAC) enumeration data.
- 5 The per capita rate is based on the shareable base less mitigation funding. The budget rate is based on a 2.33% increase in the budget and assumes matching provincial funding.

# North Bay Parry Sound District Health Unit

## Municipal Levy and Population Comparison 2021-2022

Appendix C  
Approved BOH January 26, 2022

| Municipality                     | 2021 Revised Levy |        |                    | 2022 Levy       |        |                    | Difference |
|----------------------------------|-------------------|--------|--------------------|-----------------|--------|--------------------|------------|
|                                  | *MPAC             |        | Total \$           | *MPAC           |        | Total \$           |            |
|                                  | Population 2018   |        |                    | Population 2018 |        |                    |            |
| %                                | #                 | %      | #                  |                 |        |                    |            |
| Armour                           | 1.14              | 1,126  | \$ 40,445          | 1.14            | 1,126  | \$ 41,774          | 1,329      |
| Bonfield                         | 1.85              | 1,832  | \$ 65,804          | 1.85            | 1,832  | \$ 67,966          | 2,162      |
| Burk's Falls                     | 0.72              | 708    | \$ 25,431          | 0.72            | 708    | \$ 26,266          | 835        |
| Callander                        | 3.49              | 3,444  | \$ 123,707         | 3.49            | 3,444  | \$ 127,770         | 4,063      |
| Calvin                           | 0.48              | 477    | \$ 17,134          | 0.48            | 477    | \$ 17,696          | 562        |
| Carling                          | 1.24              | 1,220  | \$ 43,821          | 1.24            | 1,220  | \$ 45,261          | 1,440      |
| Chisholm                         | 1.18              | 1,161  | \$ 41,702          | 1.18            | 1,161  | \$ 43,072          | 1,370      |
| East Ferris                      | 4.27              | 4,219  | \$ 151,545         | 4.27            | 4,219  | \$ 156,522         | 4,977      |
| Joly                             | 0.23              | 223    | \$ 8,010           | 0.23            | 223    | \$ 8,273           | 263        |
| Kearney                          | 0.70              | 694    | \$ 24,928          | 0.70            | 694    | \$ 25,747          | 819        |
| Machar                           | 0.77              | 761    | \$ 27,334          | 0.77            | 761    | \$ 28,233          | 899        |
| Magnetawan                       | 1.18              | 1,167  | \$ 41,918          | 1.18            | 1,167  | \$ 43,295          | 1,377      |
| Mattawa                          | 1.83              | 1,808  | \$ 64,943          | 1.83            | 1,808  | \$ 67,075          | 2,132      |
| Mattawan                         | 0.14              | 142    | \$ 5,100           | 0.14            | 142    | \$ 5,267           | 167        |
| McDougall                        | 2.29              | 2,266  | \$ 81,394          | 2.29            | 2,266  | \$ 84,067          | 2,673      |
| McKellar                         | 1.08              | 1,066  | \$ 38,290          | 1.08            | 1,066  | \$ 39,548          | 1,258      |
| McMurrich/Monteith               | 0.65              | 641    | \$ 23,025          | 0.65            | 641    | \$ 23,781          | 756        |
| Nipissing                        | 1.55              | 1,527  | \$ 54,849          | 1.55            | 1,527  | \$ 56,651          | 1,802      |
| North Bay                        | 44.37             | 43,828 | \$ 1,574,289       | 44.37           | 43,828 | \$ 1,625,987       | 51,698     |
| Papineau-Cameron                 | 0.82              | 810    | \$ 29,095          | 0.82            | 810    | \$ 30,050          | 955        |
| Parry Sound                      | 5.02              | 4,958  | \$ 178,090         | 5.02            | 4,958  | \$ 183,938         | 5,848      |
| Perry                            | 1.83              | 1,805  | \$ 64,834          | 1.83            | 1,805  | \$ 66,964          | 2,130      |
| Powassan                         | 3.01              | 2,975  | \$ 106,861         | 3.01            | 2,975  | \$ 110,370         | 3,509      |
| Ryerson                          | 0.56              | 550    | \$ 19,756          | 0.56            | 550    | \$ 20,405          | 649        |
| Seguin                           | 3.31              | 3,272  | \$ 117,529         | 3.31            | 3,272  | \$ 121,389         | 3,860      |
| South River                      | 0.90              | 892    | \$ 32,040          | 0.90            | 892    | \$ 33,093          | 1,053      |
| Strong                           | 1.24              | 1,222  | \$ 43,894          | 1.24            | 1,222  | \$ 45,335          | 1,441      |
| Sundridge                        | 0.82              | 808    | \$ 29,023          | 0.82            | 808    | \$ 29,976          | 953        |
| The Archipelago                  | 0.72              | 711    | \$ 25,539          | 0.72            | 711    | \$ 26,378          | 839        |
| West Nipissing                   | 11.78             | 11,635 | \$ 417,926         | 11.78           | 11,635 | \$ 431,650         | 13,724     |
| Whitestone                       | 0.83              | 821    | \$ 29,491          | 0.83            | 821    | \$ 30,459          | 968        |
| Totals                           | 100.00            | 98,769 | \$ 3,547,747       | 100.00          | 98,769 | \$ 3,664,258       | 116,511    |
| <b>Municipal Share of Budget</b> |                   |        | <b>\$3,547,747</b> |                 |        | <b>\$3,664,258</b> |            |
| <b>Per Capita</b>                |                   |        | <b>\$35.92</b>     |                 |        | <b>\$37.10</b>     |            |

\* Municipal Property Assessment Corporation Municipal Reserve Balance at November 30, 2021 \$1,792,020.31



**Municipality of  
Magnetawan**

P.O. Box 70, 4304 Hwy 520  
Magnetawan, ON  
P0A 1P0

***Lead Contact: Frank Pattillo, P.Eng.  
Greener Earth Engineering & Design  
P.O. Box 5156, 322 Ripple Lane  
Huntsville, ON  
P1H 2K6***

***Email: [greenerearthengineering@gmail.com](mailto:greenerearthengineering@gmail.com)***

**Request for Proposal 2022-02**

**Contractor – Replacement of Boat Ramp**

**4195 ON-520**

**Municipality of Magnetawan**

**Date of Issue: Tuesday February 8, 2022**

**Proposal Submission Deadline Friday March 11, 2022 at 3:00 p.m.**

## Section 1 Introduction and General Instructions

### 1.01 Introduction

The Municipality of Magnetawan is inviting bids and design proposals from a Contractor (hereinafter referred to as “the Bidder”) to provide construction services for the removal and replacement of the existing boat launch ramp located at 4195 ON-520, Magnetawan. The successful Bidder shall provide all material, labour, and equipment as necessary for the completion of the project as detailed within. Also required will be the site supervision by staff fully experienced with all materials and methods to be utilized in the completion of the project.

This Request for Proposals document (and any other applicable attachments or addenda) is available in PDF format through the Municipality of Magnetawan’s website at [www.magnetawan.com](http://www.magnetawan.com)

Any information contained in the Request for Proposal that is changed by the Bidder (except for filling in the blanks) will be grounds for disqualification.

Magnetawan’s Procurement By-law is available for review at the Municipal Office or on the website.

### 1.02 Submission of Proposals

Proposals shall be submitted in the form and format specified in Section 3 and shall include the completed Form of Proposal included as Section 5 at the end of this document. A designated signing officer authorized to bind the Bidder to the provisions of their Proposal must sign the Form of Proposal. Any addenda issued by the Municipality of Magnetawan in accordance with Subsection 1.06 must be acknowledged by the Bidder on the Form of Proposal.

All hard copy proposals must be signed, sealed, the envelope marked with the Bidder’s name and the Project Name, and received by: The Municipality of Magnetawan, PO Box 70, 4304 Hwy 520, Magnetawan, ON P0A 1P0.

Electronic submissions will be accepted in response to this RFP due to COVID-19 Pandemic. Electric submissions will not be reviewed until the proposal opening.

Faxed submissions will not be accepted.

**Project Name: RFP 2022-02 Contractor – Replacement of Boat Launch Ramp – 4195 ON-520.**

**Proposals must be received no later than Friday March 11, 2022 at 3:00 p.m.**

Proposals must not be restricted by a statement added to the Form of Proposal or by a covering letter, or by alterations to the Form of Proposal supplied unless otherwise provided in the RFP.

The onus unequivocally remains with the Bidder to ensure that the Municipality of Magnetawan receives proposals delivered or sent by courier prior to the Proposal Submission Deadline, in accordance with the submission process described in this section. Proposals received after the Proposal Submission Deadline will not be considered.



### 1.03 Contacts

All questions or inquiries must be made in writing or email to the Lead Contact named below:

**Frank Pattillo, P.Eng.**  
**Greener Earth Engineering & Design**  
**P.O. Box 5156, 322 Ripple Lane**  
**Huntsville, ON**  
**P1H 2K6**

**Email: [greenerearthengineering@gmail.com](mailto:greenerearthengineering@gmail.com)**

**IMPORTANT:** A Bidder may be disqualified if they make inquiries, between the Proposal issue date and the notification of the Award, in a manner other than that described in this RFP or to anyone involved in the process who is not the Lead Contact, including but not limited to the members of Council. This is to ensure that each Bidder receives the same information, and that no Bidder receives unfair treatment during the RFP process.

### 1.04 Schedule

The schedule set out herein represents the Municipality of Magnetawan's best estimate of the schedule that will be followed, and it is intended to be a guideline.

The approximate schedule is as follows:

|                                  |                                    |
|----------------------------------|------------------------------------|
| RFP issue date                   | Tuesday February 8, 2022           |
| Final date of posting of addenda | Friday March 4, 2022 by 4:30 p.m.  |
| Proposal Submission Deadline     | Friday March 11, 2022 by 3:00 p.m. |
| Proposal Opening                 | Friday March 11, 2022 by 3:30 p.m. |

### 1.05 Required Review and Clarification

Bidders shall carefully review this RFP. If questions concerning clarification of the contents of this document arise, the questions must be made in writing and received by the Lead Contact. This will allow time for the issuance of any necessary addenda. Protests based on any omission or error or on the content of the RFP will be disallowed if these perceived faults have not been brought to the attention of the Lead Contact.

In submitting a Proposal, the Bidder acknowledges that they have read, completely understood, and accepted the terms and conditions of the RFP in full. The Municipality of Magnetawan is not responsible for any misunderstanding of the RFP.

### 1.06 Amendments to the RFP

The Municipality of Magnetawan may issue addenda as they are received, clarify and/or modify certain aspects of the RFP prior to the Proposal Submission Deadline. No addenda shall be posted after **Friday March 4, 2022**. Addenda will be posted to our website at [www.magnetawan.com](http://www.magnetawan.com) and shall be available in the Municipal Office.

## 1.07 Opening of Proposals

A Request for Proposals is evaluated on a more comprehensive set of criteria than a Tender. As such, the contract will not be awarded at the opening, but only after the Evaluation Committee has examined all Proposals in detail and presented their recommendation to Council. Bidders will be notified of the date for the Council meeting at which the Award will be decided, and they are welcome to attend.

## 1.08 Reserved Rights of the Municipality of Magnetawan

The Municipality of Magnetawan reserves the right to:

- a. make public the names of any or all Bidders and their quoted price;
- b. request written clarification or the submission of supplementary written information in relation to the clarification request from any Bidder and incorporate a Bidder's response to that request for clarification into the Bidder's Proposal;
- c. adjust a Bidder's scoring or reject a Bidder's Proposal on the basis of
  - i) a financial analysis;
  - ii) information provided by references;
  - iii) the Bidder's past performance on previous contracts awarded by the Municipality of Magnetawan;
  - iv) the information provided by a Bidder pursuant to the Municipality of Magnetawan exercising its clarification rights under this RFP process; or
  - v) other relevant information that arises during the RFP process;
- d. verify with any Bidder or with a third party any information set out in a Proposal;
- e. check references other than those provided by any Bidder;
- f. disqualify any Bidder whose Proposal contains misrepresentations or any other inaccurate or misleading information, or any qualifications;
- g. disqualify any Bidder or the Proposal of any Bidder who has engaged in conduct prohibited by this RFP;
- h. make changes, including substantial changes, to this RFP provided that those changes are issued by way of addenda in the manner set out in this RFP;
- i. select the Bidder other than the Bidder whose Proposal reflects the lowest cost to the Municipality of Magnetawan or the highest overall score;
- j. cancel this RFP process at any stage;
- k. cancel this RFP process at any stage and issue a new RFP for the same or similar deliverables;
- l. accept or reject any or all Proposals in whole or in part;
- m. discuss with any Bidder different or additional terms to those contemplated in this RFP or in any Bidder's Proposal;
- n. if a single Proposal is received, reject the Proposal of the sole Bidder, and cancel this RFP process or enter into direct negotiations with the sole Bidder.
- o. to negotiate with the two lowest bidders.

These reserved rights are in addition to any other expressed rights or any other rights which may be implied in the circumstances.

## 1.09 Not Responsible for Costs

The Municipality of Magnetawan shall not pay any costs associated with the preparation, submission, or presentation of the Bidder's Proposal. The Municipality of Magnetawan shall not be liable for any expenses, costs or losses suffered by the Bidder or any third party resulting from the Municipality of Magnetawan exercising any of its expressed or implied rights under this RFP.

### **1.10 Proposal Expiry Date**

Bidders hereby acknowledge that their Proposals shall be irrevocable for a period of **90 days** from the Proposal submission deadline. Extensions to this period may be granted with the mutual agreement of the Municipality of Magnetawan and the successful Bidder and may be initiated by either party.

### **1.11 Confidentiality and Ownership**

Any information provided to the Bidder by the Municipality of Magnetawan before, during or after the project is completed shall be treated as confidential and shall not be used or communicated by the Bidder or any third party in any way unless otherwise identified or permitted by the Municipality of Magnetawan. The information, reports, documentation, plans, etc. that are produced by the successful Bidder in response to this project shall become the exclusive property of the Municipality of Magnetawan; however, intellectual property, such as specific tools, templates, processes, etc. that the Bidder provides as part of the deliverables remains the property of the Bidder.

### **1.12 Invoicing**

The request for proposal shall include an outline of the payment invoicing schedule. It should be noted that the Municipality of Magnetawan's standard terms of payment are net 30 days from the date of when the invoice is received.

### **1.13 Freedom of Information**

Any personal information required in the Proposal is received under the authority of the Municipality of Magnetawan. This information shall be an integral component of the submission. All written Proposals received by the Municipality of Magnetawan become a public record. Once a Proposal is accepted by the Municipality of Magnetawan and the contract has been awarded, all information contained in the Proposals may be available to the public, including personal information. Questions about the collection of personal information and the Municipal Freedom of Information and Protection of Privacy Act, 1989, R.S.O. 1990, as amended may be directed to the Lead Contact.

### **1.14 Additional Requirements**

- (a) The use of appropriate and credible sub-contractors by the Bidder to perform portions of the project is permitted only if the Bidder declares such use in the Proposal;
- (b) The successful Bidder shall, throughout the term of the contract, obtain and maintain in force a General Liability Insurance and/or Professional Liability Insurance coverage of not less than \$5,000,000 per occurrence inclusive, to indemnify and hold harmless the Municipality of Magnetawan against any liability for property damage or personal injury, including death, which may arise from the Bidder's operations under this contract;
- (c) The successful Bidder shall ensure that all services and products provided in respect to this proposal are done so in accordance with and under the authorization of all applicable authorities, municipal, provincial, and/or federal legislation, including but not limited to WSIB and all applicable responsibilities under Occupational Health and Safety Act.

## **1.15 Contract for Consulting Services**

The successful Bidder shall enter into a Construction Services Contract with the Municipality of Magnetawan following award of this RFP. The contract will cover a range of issues including but not limited to fees and rates, notice of staff changes, Contract term and renewal, and Contract cancellation. The Contract will require the successful Bidder to acknowledge the Municipality of Magnetawan's right to direct specialized work, large projects, or other necessary projects to a competitive procurement process. If mutually acceptable terms and conditions can be reached between the successful Bidder and the Municipality of Magnetawan, the Contract shall be signed. In the event of a failure to arrive at a mutually acceptable Contract, the Municipality of Magnetawan may accept a Bid from a different Bidder or carry out the work in any other way deemed appropriate by the Council of the Municipality of Magnetawan.

## **Section 2 Scope of Work and Project Requirements**

### **2.01 Municipality of Magnetawan Description**

The Municipality of Magnetawan is situated in the east portion of the District of Parry Sound in the Province of Ontario and has a land area of approximately 530 square kilometres and a population of approximately 1,450 (2011). The boat ramp to be replaced is located directly off Highway 520 in the downtown area of Magnetawan at the end of Lion's Park Bay (where the Magnetawan river between Lake Cecebe and Ahmic Lake approaches the downtown core).

### **2.02 Project Background & Scope**

Due to the existing condition of the existing boat launch ramp, the Municipality of Magnetawan requested a review of the structure by an engineering firm to assist in determining the best options for repair/replacement of the ramp. The existing ramp has been constructed from two rows of 24" wide x 6'-6" long pre-cast concrete slabs that are supported on granular material above the water level and on wooden timbers where the ramp extends into the water. The overall dimensions of the existing ramp are approximately 13'-6" wide, 17'-6" long above the water level and approximately 14'-0" below the water for an overall length of approximately 32'-0". Ramp slope has been estimated at 2.5/12 or about 12 degrees. Primarily due to frost action, the existing pre-cast concrete slabs have cracked in numerous places and the ramp itself is heaved and uneven. Based on the engineer's review of the ramp condition and the recommendations of the report, the Municipality has determined that ramp replacement is the best option with the desired construction to be a pre-cast ramp slabs on a crushed stone base both on land and in the water portion. The replacement pre-cast slabs should be designed and manufactured to provide both traction and to prevent the accumulation of water that can freeze and break down the concrete. Slabs are to be modular, with individual replacement as necessary without the need for replacing the whole ramp. The new ramp size should approximate the existing overall ramp dimensions and slope. Usable life expectancy of the replacement ramp should be a minimum of 20 years.

### **2.03 Required Services**

The services to be provided by the successful Bidder will include but not be limited to those areas as set out below. Generally, services provided by the successful Bidder in each area shall include but not be limited to investigating, pre-design, design review, detailed design, contract administration, obtaining necessary approvals, demolition, construction, and project management.

The successful Bidder shall have staff resources, equipment, and expertise to provide design and construction services, technical skills and knowledge in, as a minimum, the following areas:

- Site assessment.
- Geotechnical/hydrological assessment as required.
- Acceptable design solutions and recommendations (MNDMNR, DFO approvals as required).
- Design (c/w practical project completion timeline for the construction work).
- Provision of formal shop drawings for approval prior to commencing work.
- Demolition & disposal of the existing construction.
- New ramp layout, construction, and construction supervision.

### Section 3 Proposal Submission Requirements

For the Municipality of Magnetawan to evaluate Proposals fairly and completely, Bidders shall provide **all** of the information requested in the format set out in the RFP. Failure to provide all required information as detailed in this section may result in the Bidder being disqualified or scoring poorly in the evaluation.

Each Proponent shall submit their Proposal, containing the following items:

- An indication of the Bidder's understanding of the project scope and requirements, including how each of the specific required services shall be met;
- An overview of the Company submitting the proposal, along with an overview of any sub-contractors which will be taking part in the work on behalf of the Bidder, and their legal/contractual relationship to the Bidder;
- An overview of the Bidder's experience and expertise in the areas identified in Section 2.03, as well as the expertise of any sub-contractors that will be involved as part of the Bidder's team. The Bidder shall include at least two (2) references that outline their previous or current construction projects of a similar nature as required in this RFP, with Ontario municipalities, with specific experience in marine installations including the reference contact name, email, and telephone number. The Municipality of Magnetawan reserves the right to contact these or any other references where appropriate. The Bidder may include additional references for specific areas/projects;
- Resume/Curriculum Vitae for the Bidder's Project Manager and any other staff proposed to be working on behalf of the Bidder in a significant role;
- Proof of qualifications (i.e., copies of professional certificates)
- A detailed financial breakdown of all relevant project costs, including a 2022/2023 fee schedule for the various services, staff hourly and per diem rates, rates or fees for expenses and attendance at meetings with Municipality of Magnetawan staff or Council, and any other relevant fees or expenses.
- A detailed outline of the payment/invoicing schedule.

### Section 4 Evaluation of the Proposals

#### 4.01 Evaluation Criteria, Process and Award

As part of the evaluation process, the Municipality of Magnetawan may contact one or more Bidders to clarify or obtain more information about their Proposal or to request the Bidder to exhibit or otherwise demonstrate the information contained therein. The purpose of these discussions will be to ensure full understanding of the requirements of the RFP and Proposal. Discussions will be limited to specific sections of the RFP identified by the evaluation committee. The Lead Contact will only hold discussions with Bidders who have submitted a proposal deemed to be reasonably acceptable for Award.

The Municipality of Magnetawan may make an Award on the basis of the Proposals received without further discussion with the Bidders. Therefore, each initial offer should contain the Bidder's best terms/information, including all required documentation as listed in this RFP.

The evaluation committee will recommend Award to Council for the Bidder achieving the most cost effective and practical design recommendation.

**Section 5 Form of Proposal**

I/We, the Undersigned, having examined this Request for Proposals, do hereby offer to enter into an Agreement with the Municipality of Magnetawan to act as Engineer of Record under the terms as included.

I,We \_\_\_\_\_  
(Name-Print) (Position)

of \_\_\_\_\_  
(Company Name)

Dated at \_\_\_\_\_ this \_\_\_\_\_ day of \_\_\_\_\_, 2019.

\_\_\_\_\_  
AUTHORIZED SIGNATURE

\_\_\_\_\_  
STREET ADDRESS

\_\_\_\_\_  
CITY PROVINCE POSTAL CODE

\_\_\_\_\_  
TELEPHONE NO. FACSIMILE NO. E-MAIL ADDRESS

Receipt of any issued addenda shall be acknowledged by initialing in the space provided below.

Last posted addendum on the website on Friday March 4, 2022 \_\_\_\_\_

Signature in the designated space, by an authorized officer of the Bidder's company affirms acceptance of the Request for Proposal requirements set forth in this document, the associated costs attributed to the business arrangement between the Bidder and the Municipality of Magnetawan, and hereby certifies that the information supplied in this proposal to be true and complete in all respects.

Company Seal



**Municipality of  
Magnetawan**

P.O. Box 70, 4304 Hwy 520  
Magnetawan, ON  
P0A 1P0

***Lead Contact: Frank Pattillo, P.Eng.  
Greener Earth Engineering & Design  
P.O. Box 5156, 322 Ripple Lane  
Huntsville, ON  
P1H 2K6***

***Email: [greenerearthengineering@gmail.com](mailto:greenerearthengineering@gmail.com)***

**Request for Proposal 2022-03**

**Contractor – Roof Repair/Replacement  
Municipality of Magnetawan Municipal Office Building  
4304 Hwy #520  
Magnetawan, Ontario**

**Date of Issue: Wednesday February 23, 2022**

**Proposal Submission Deadline Friday March 25, 2022 at 3:00 p.m.**

**Section 1 Introduction and General Instructions**

**1.01 Introduction**

The Municipality of Magnetawan is inviting bids and design proposals from a Contractor (hereinafter referred to as “the Bidder”) to provide construction services for the installation of a secondary roof structure over the existing roof framing of the municipal office building and community centre located at 4304 ON-520, Magnetawan. The successful Bidder shall provide all material, labour, and equipment as necessary for the completion of the project as detailed within. Also required will be the site supervision by staff fully experienced with all materials and methods to be utilized in the completion of the project.

This Request for Proposals document (and any other applicable attachments or addenda) is available in PDF format through the Municipality of Magnetawan’s website at [www.magnetawan.com](http://www.magnetawan.com)

Any information contained in the Request for Proposal that is changed by the Bidder (except for filling in the blanks) will be grounds for disqualification.

Magnetawan’s Procurement By-law is available for review at the Municipal Office or on the website.

**1.02 Submission of Proposals**

Proposals shall be submitted in the form and format specified in Section 3 and shall include the completed Form of Proposal included as Section 5 at the end of this document. A designated signing officer authorized to bind the Bidder to the provisions of their Proposal must sign the Form of Proposal. Any addenda issued by the Municipality of Magnetawan in accordance with Subsection 1.06 must be acknowledged by the Bidder on the Form of Proposal.

All hard copy proposals must be signed, sealed, the envelope marked with the Bidder’s name and the Project Name, and received by: The Municipality of Magnetawan, PO Box 70, 4304 Hwy 520, Magnetawan, ON P0A 1P0.

Electronic submissions will be accepted in response to this RFP due to COVID-19 Pandemic. Electronic submissions will not be reviewed until the proposal opening.

Faxed submissions will not be accepted.

**Project Name: RFP 2022-03 Contractor – Roof Repair/Replacement Municipal Office Building – 4304 ON-520.**

**Proposals must be received no later than Friday March 25, 2022 at 3:00 p.m.**

Proposals must not be restricted by a statement added to the Form of Proposal or by a covering letter, or by alterations to the Form of Proposal supplied unless otherwise provided in the RFP.

The onus unequivocally remains with the Bidder to ensure that the Municipality of Magnetawan receives proposals delivered or sent by courier prior to the Proposal Submission Deadline, in accordance with the submission process described in this section. Proposals received after the Proposal Submission Deadline will not be considered.



### 1.03 Contacts

All questions or inquiries must be made in writing or email to the Lead Contact named below:

**Frank Pattillo, P.Eng.  
Greener Earth Engineering & Design  
P.O. Box 5156, 322 Ripple Lane  
Huntsville, ON  
P1H 2K6**

**Email: [greenerearthengineering@gmail.com](mailto:greenerearthengineering@gmail.com)**

**IMPORTANT:** A Bidder may be disqualified if they make inquiries, between the Proposal issue date and the notification of the Award, in a manner other than that described in this RFP or to anyone involved in the process who is not the Lead Contact, including but not limited to the members of Council. This is to ensure that each Bidder receives the same information, and that no Bidder receives unfair treatment during the RFP process.

### 1.04 Schedule

The schedule set out herein represents the Municipality of Magnetawan's best estimate of the schedule that will be followed, and it is intended to be a guideline.

The approximate schedule is as follows:

|                                  |                                    |
|----------------------------------|------------------------------------|
| RFP issue date                   | Wednesday February 23, 2022        |
| Final date of posting of addenda | Friday March 18, 2022 by 4:30 p.m. |
| Proposal Submission Deadline     | Friday March 25, 2022 by 3:00 p.m. |
| Proposal Opening                 | Friday March 25, 2022 by 3:30 p.m. |

### 1.05 Required Review and Clarification

Bidders shall carefully review this RFP. If questions concerning clarification of the contents of this document arise, the questions must be made in writing and received by the Lead Contact. This will allow time for the issuance of any necessary addenda. Protests based on any omission or error or on the content of the RFP will be disallowed if these perceived faults have not been brought to the attention of the Lead Contact.

In submitting a Proposal, the Bidder acknowledges that they have read, completely understood, and accepted the terms and conditions of the RFP in full. The Municipality of Magnetawan is not responsible for any misunderstanding of the RFP.

### 1.06 Amendments to the RFP

The Municipality of Magnetawan may issue addenda as they are received, clarify and/or modify certain aspects of the RFP prior to the Proposal Submission Deadline. No addenda shall be posted after **Friday March 18, 2022**. Addenda will be posted to our website at [www.magnetawan.com](http://www.magnetawan.com) and shall be available in the Municipal Office.

## 1.07 Opening of Proposals

A Request for Proposals is evaluated on a more comprehensive set of criteria than a Tender. As such, the contract will not be awarded at the opening, but only after the Evaluation Committee has examined all Proposals in detail and presented their recommendation to Council. Bidders will be notified of the date for the Council meeting at which the Award will be decided, and they are welcome to attend.

## 1.08 Reserved Rights of the Municipality of Magnetawan

The Municipality of Magnetawan reserves the right to:

- a. make public the names of any or all Bidders and their quoted price;
- b. request written clarification or the submission of supplementary written information in relation to the clarification request from any Bidder and incorporate a Bidder's response to that request for clarification into the Bidder's Proposal;
- c. adjust a Bidder's scoring or reject a Bidder's Proposal on the basis of
  - i) a financial analysis;
  - ii) information provided by references;
  - iii) the Bidder's past performance on previous contracts awarded by the Municipality of Magnetawan;
  - iv) the information provided by a Bidder pursuant to the Municipality of Magnetawan exercising its clarification rights under this RFP process; or
  - v) other relevant information that arises during the RFP process;
- d. verify with any Bidder or with a third party any information set out in a Proposal;
- e. check references other than those provided by any Bidder;
- f. disqualify any Bidder whose Proposal contains misrepresentations or any other inaccurate or misleading information, or any qualifications;
- g. disqualify any Bidder or the Proposal of any Bidder who has engaged in conduct prohibited by this RFP;
- h. make changes, including substantial changes, to this RFP provided that those changes are issued by way of addenda in the manner set out in this RFP;
- i. select the Bidder other than the Bidder whose Proposal reflects the lowest cost to the Municipality of Magnetawan or the highest overall score;
- j. cancel this RFP process at any stage;
- k. cancel this RFP process at any stage and issue a new RFP for the same or similar deliverables;
- l. accept or reject any or all Proposals in whole or in part;
- m. discuss with any Bidder different or additional terms to those contemplated in this RFP or in any Bidder's Proposal;
- n. if a single Proposal is received, reject the Proposal of the sole Bidder, and cancel this RFP process or enter into direct negotiations with the sole Bidder.
- o. to negotiate with the two lowest bidders.

These reserved rights are in addition to any other expressed rights or any other rights which may be implied in the circumstances.

## 1.09 Not Responsible for Costs

The Municipality of Magnetawan shall not pay any costs associated with the preparation, submission, or presentation of the Bidder's Proposal. The Municipality of Magnetawan shall not be liable for any expenses, costs or losses suffered by the Bidder or any third party resulting from the Municipality of Magnetawan exercising any of its expressed or implied rights under this RFP.

### **1.10 Proposal Expiry Date**

Bidders hereby acknowledge that their Proposals shall be irrevocable for a period of **90 days** from the Proposal submission deadline. Extensions to this period may be granted with the mutual agreement of the Municipality of Magnetawan and the successful Bidder and may be initiated by either party.

### **1.11 Confidentiality and Ownership**

Any information provided to the Bidder by the Municipality of Magnetawan before, during or after the project is completed shall be treated as confidential and shall not be used or communicated by the Bidder or any third party in any way unless otherwise identified or permitted by the Municipality of Magnetawan. The information, reports, documentation, plans, etc. that are produced by the successful Bidder in response to this project shall become the exclusive property of the Municipality of Magnetawan; however, intellectual property, such as specific tools, templates, processes, etc. that the Bidder provides as part of the deliverables remains the property of the Bidder.

### **1.12 Invoicing**

The request for proposal shall include an outline of the payment invoicing schedule. It should be noted that the Municipality of Magnetawan's standard terms of payment are net 30 days from the date of when the invoice is received.

### **1.13 Freedom of Information**

Any personal information required in the Proposal is received under the authority of the Municipality of Magnetawan. This information shall be an integral component of the submission. All written Proposals received by the Municipality of Magnetawan become a public record. Once a Proposal is accepted by the Municipality of Magnetawan and the contract has been awarded, all information contained in the Proposals may be available to the public, including personal information. Questions about the collection of personal information and the Municipal Freedom of Information and Protection of Privacy Act, 1989, R.S.O. 1990, as amended may be directed to the Lead Contact.

### **1.14 Additional Requirements**

- (a) The use of appropriate and credible sub-contractors by the Bidder to perform portions of the project is permitted only if the Bidder declares such use in the Proposal;
- (b) The successful Bidder shall, throughout the term of the contract, obtain and maintain in force a General Liability Insurance and/or Professional Liability Insurance coverage of not less than \$5,000,000 per occurrence inclusive, to indemnify and hold harmless the Municipality of Magnetawan against any liability for property damage or personal injury, including death, which may arise from the Bidder's operations under this contract;
- (c) The successful Bidder shall ensure that all services and products provided in respect to this proposal are done so in accordance with and under the authorization of all applicable authorities, municipal, provincial, and/or federal legislation, including but not limited to WSIB and all applicable responsibilities under Occupational Health and Safety Act.

## 1.15 Contract for Consulting Services

The successful Bidder shall enter into a Construction Services Contract with the Municipality of Magnetawan following award of this RFP. The contract will cover a range of issues including but not limited to fees and rates, notice of staff changes, Contract term and renewal, and Contract cancellation. The Contract will require the successful Bidder to acknowledge the Municipality of Magnetawan's right to direct specialized work, large projects, or other necessary projects to a competitive procurement process. If mutually acceptable terms and conditions can be reached between the successful Bidder and the Municipality of Magnetawan, the Contract shall be signed. In the event of a failure to arrive at a mutually acceptable Contract, the Municipality of Magnetawan may accept a Bid from a different Bidder or carry out the work in any other way deemed appropriate by the Council of the Municipality of Magnetawan.

## Section 2 Scope of Work and Project Requirements

### 2.01 Municipality of Magnetawan Description

The Municipality of Magnetawan is situated in the east portion of the District of Parry Sound in the Province of Ontario and has a land area of approximately 530 square kilometres and a population of approximately 1,450 (2011). The roof area to be repaired/replaced is located on the building containing the Municipal Office and Community Centre with a municipal address of 4304 ON-520.

### 2.02 Project Background & Scope

Due to ongoing issues with leakage and ice build-up on the existing roof area over the municipal office building, the Municipality of Magnetawan requested a review of the structure by an engineering firm to assist in determining the cause(s) and options for correcting the problems. Based upon the review of both the existing roof construction and the building design documents, it was determined that the root cause of the ice damming on this roof structure was not from a single source but was the result of a combination of factors including poor ventilation, inadequate or poorly installed insulation and excess heat entry into the attic spaces. The existing roof is a combination type with trusses on two ends and a rafter section in the middle portion of one side to allow for a 2<sup>nd</sup> level mezzanine below. Overall roof area on this portion of the building is approximately 5,000 sq.ft. and is finished with plywood sheathing covered with exposed fastener galvanized steel roofing. Roof pitch at the front portion is 3:12 with a pitch of 0.5:12 at the rear section. Due to the nature of the existing roof construction, it was suggested that the most logical solution would be to install a hybrid secondary roof over the existing composed of 2" of spray foam insulation onto the existing metal roof along with dimensional lumber sleepers (2"x6" on edge) over framed onto the existing structure with a secondary metal roof finish on top. With a minimum extension of the joists of 3" beyond the spray foam, an unobstructed ventilation space from the eaves to the peak would be created. Structural capacity of the existing roof has been evaluated and maximum additional roof dead load up to 10 lbs/sq.ft. can be added.

Contractors are also requested to provide an additional and separate proposal for extending the sleepers and secondary metal roofing only over the adjacent community centre roof area. This roof does not have the same insulation and ice damming issues but does have some minor leaks. The extended roof area would prevent a step between the two roof areas and maintain a uniform roof appearance over the entire building. Total roof area over this portion of the building is approximately 7,650 sq.ft. with similar roof slopes as noted above.

The Municipality is willing to entertain additional options with respect to the most economical methods of correcting the ongoing issues and bidding contractors are encouraged to present alternative options as part of their proposal package.

## 2.03 Required Services

The services to be provided by the successful Bidder will include but not be limited to those areas as set out below. Generally, services provided by the successful Bidder in each area shall include but not be limited to investigating, pre-design, design review, detailed design, contract administration, obtaining necessary approvals, demolition, construction, and project management.

The successful Bidder shall have staff resources, equipment, and expertise to provide design and construction services, technical skills, and knowledge in, as a minimum, the following areas:

- Site assessment and evaluation.
- Acceptable roofing system design solutions and recommendations.
- Roof system design (c/w practical project completion timeline for the construction work).
- Provision of formal shop drawings for approval prior to commencing work.
- Demolition & disposal of the existing construction (if required).
- New roof system layout, construction, and construction supervision.

## Section 3 Proposal Submission Requirements

For the Municipality of Magnetawan to evaluate Proposals fairly and completely, Bidders shall provide all of the information requested in the format set out in the RFP. Failure to provide all required information as detailed in this section may result in the Bidder being disqualified or scoring poorly in the evaluation.

Each Proponent shall submit their Proposal, containing the following items:

- An indication of the Bidder's understanding of the project scope and requirements, including how each of the specific required services shall be met;
- An overview of the Company submitting the proposal, along with an overview of any sub-contractors which will be taking part in the work on behalf of the Bidder, and their legal/contractual relationship to the Bidder;
- An overview of the Bidder's experience and expertise in the areas identified in Section 2.03, as well as the expertise of any sub-contractors that will be involved as part of the Bidder's team. The Bidder shall include at least two (2) references that outline their previous or current construction projects of a similar nature as required in this RFP, with Ontario municipalities, with specific experience in over framed/secondary roofing systems including the reference contact name, email, and telephone number. The Municipality of Magnetawan reserves the right to contact these or any other references where appropriate. The Bidder may include additional references for specific areas/projects;
- Resume/Curriculum Vitae for the Bidder's Project Manager and any other staff proposed to be working on behalf of the Bidder in a significant role;
- Proof of qualifications (i.e., copies of professional certificates)
- A detailed financial breakdown of all relevant project costs, including a 2022/2023 fee schedule for the various services, staff hourly and per diem rates, rates or fees for expenses and attendance at meetings with Municipality of Magnetawan staff or Council, and any other relevant fees or expenses.
- A detailed outline of the payment/invoicing schedule.

## Section 4 Evaluation of the Proposals

### 4.01 Evaluation Criteria, Process and Award

As part of the evaluation process, the Municipality of Magnetawan may contact one or more Bidders to clarify or obtain more information about their Proposal or to request the Bidder to exhibit or otherwise demonstrate the information contained therein. The purpose of these discussions will be to ensure full understanding of the requirements of the RFP and Proposal. Discussions will be limited to specific sections of the RFP identified by the evaluation committee. The Lead Contact will only hold discussions with Bidders who have submitted a proposal deemed to be reasonably acceptable for Award.

The Municipality of Magnetawan may make an Award on the basis of the Proposals received without further discussion with the Bidders. Therefore, each initial offer should contain the Bidder's best terms/information, including all required documentation as listed in this RFP.

The evaluation committee will recommend Award to Council for the Bidder achieving the most cost effective and practical design recommendation.

**Section 5 Form of Proposal**

I/We, the Undersigned, having examined this Request for Proposals, do hereby offer to enter into an Agreement with the Municipality of Magnetawan to act as Contractor under the terms as included.

I, We \_\_\_\_\_  
(Name-Print) (Position)

of \_\_\_\_\_  
(Company Name)

Dated at \_\_\_\_\_ this \_\_\_\_\_ day of \_\_\_\_\_, 2019.

\_\_\_\_\_  
AUTHORIZED SIGNATURE

\_\_\_\_\_  
STREET ADDRESS

\_\_\_\_\_  
CITY PROVINCE POSTAL CODE

\_\_\_\_\_  
TELEPHONE NO. FACSIMILE NO. E-MAIL ADDRESS

Receipt of any issued addenda shall be acknowledged by initialing in the space provided below.

Last posted addendum on the website on Friday March 18, 2022 \_\_\_\_\_

Signature in the designated space, by an authorized officer of the Bidder's company affirms acceptance of the Request for Proposal requirements set forth in this document, the associated costs attributed to the business arrangement between the Bidder and the Municipality of Magnetawan, and hereby certifies that the information supplied in this proposal to be true and complete in all respects.

Company Seal



## Magnetawan - Cedar Croft

Our new tower in the Cedar Croft area is NOW LIVE!

Up to 50 Mbps available\*!

\*Availability dependent on location



INTERNET SOLUTIONS



# Municipality of Magnetawan



February 2022 Newsletter

## Quick Links

Explore  
Government  
Residents  
News  
Join Our Mailing List  
Privacy Policy

## Read All About It !!!

Want to be the first to hear about Municipal News and Events? Join our Mailing List! Visit our website at [www.magnetawan.com](http://www.magnetawan.com) You can find the **JOIN OUR MAILING LIST** on the bottom of the **HOMEPAGE** under **QUICK LINKS**. Do not forget to confirm your subscription!! (If you do not receive a confirmation email, check your **JUNK MAIL!**)

Are you a **local business** located in the Municipality of Magnetawan? Or does your business support the residents within the Municipality? Sign up for our Business Directory. Visit our website at [www.magnetawan.com](http://www.magnetawan.com) You can find the **ADD YOUR BUSINESS** on top of the **BUSINESS DIRECTORY PAGE** under the **EXPLORE** tab.

## BUSINESS DIRECTORY

Here that applicants register in compliance requests will be at the discretion of the C&D

Disclaimer: The Municipality remains liable for any errors or omissions in the information provided.

Add Your Business

## Are you a community group located in the Municipality of Magnetawan?

Would you like your community group to be included on the Municipality Website? Reach out to us at [info@magnetawan.com](mailto:info@magnetawan.com) with a short description of your group along with any website or social media information!



In **August**, the Municipality of Magnetawan began the review process of its Official Plan and Zoning By-law. We're excited to announce we have received incredible feedback and responses thus far! So, **THANK YOU** to our ratepayers for getting involved and telling us your thoughts. The process isn't over! Keep your eyes out for an announcement of an **Open House** in late winter/early spring to view the draft documents and mapping! If you want to receive future notices on the process, please sign up for our e-mail newsletter on our website or email **Nicole Gourlay** at [planning@magnetawan.com](mailto:planning@magnetawan.com) These documents will help shape the future of our community and we want to hear from **YOU!** Please get involved and let your voice be heard.

## WARNING PHRAGMITES!!!!

Phragmites Australis, is an invasive, non-native reed grass that has established itself in and around the shore of Old Man's Lake as well as other areas within the Municipality of Magnetawan. Phragmites may be on your shoreline property and if so, you will want to remove it quickly. For further information on the Phragmites volunteer program under the Near North Enviro Education Centre please **contact** [www.nneec.ca/phragmites](http://www.nneec.ca/phragmites)



## DO YOU KNOW A SUPER SENIOR?

The Ontario Senior of the Year award gives each Municipality in Ontario, the opportunity to honour one outstanding local Ontarian who, after the age of 65, has enriched the social, cultural, or civic life of their community. If you would like to nominate a **SUPER SENIOR** from our Municipality for this prestigious provincial award, please send your nomination telling us why this person is a **SUPER SENIOR** to [lbrandt@magnetawan.com](mailto:lbrandt@magnetawan.com) or drop it off at the Municipal Office by **March 11, 2022**



## Building Permit Reminders!

Please ensure you obtain a building permit before you build or renovate. When in doubt give the building department a shout! (705) 387-4029.

Applications are available online on our applications and licensing page on our website at [www.magnetawan.com](http://www.magnetawan.com) or by reaching out to the Municipal Office at (705) 387-3947 or by email at [info@magnetawan.com](mailto:info@magnetawan.com)

The Municipal Office is located at

4304 Highway 520, Magnetawan,  
Ontario POA 1P0  
705-387-3947

Please visit our website at  
[www.magnetawan.com](http://www.magnetawan.com)  
or email us at  
[info@magnetawan.com](mailto:info@magnetawan.com)

and  Like The Municipality of Magnetawan on Facebook!

## Property tax due dates for 2022:

For 2022, the payment dates for your property taxes are on the 23rd day of March, June, September, November.



Visit our website for more information  
[magnetawanlibrary.com](http://magnetawanlibrary.com)  
Or call (705) 387-4411

## Council Meetings

Council generally meets every third Wednesday at 1:00 p.m.

As always Council agendas and meeting dates are posted on our website for your convenience!

2022 ONTARIO MUNICIPAL AND SCHOOL BOARD ELECTIONS

OCTOBER 24, 2022

ON THE LIST TO VOTE?

HAVE YOUR SAY!



VISIT [VOTERLOOKUP.CA](http://VOTERLOOKUP.CA)

Have you moved or changed your mailing address? Mailing address changes must be submitted in writing. Please also remember to notify MPAC directly of your address change

**How to Pay?** You can pay your tax bill through your online banking by adding us as a payee and using your 19 digit roll number as your account number. **You can also visit your bank and pay directly through a teller.** If you would like to pay by credit card you can use the payment service "Plastiq" found on our website. Please keep in mind that payments made online, at your bank and using "Plastiq" can take up to five (5) business days to process and if you are paying for multiple properties, please ensure each roll number is paid individually. **Also,** Cash, or cheques are accepted at the office, in person or through our drop box located at the front of the building (facing Highway 520). You can also mail your cheque. Please remember if paying by cash or cheque in person that you bring your tax installment notice so, we can identify the property that the payment will be applied to **OR** please ensure all roll numbers are written on your cheque.



**2022 MUNICIPAL ELECTION HAVE YOUR SAY!**

The **2022 Ontario Municipal and School Board Election** is on **October 24, 2022.** Voters will have the convenience of choosing to vote by **MAIL, TELEPHONE, or INTERNET.**



**Dog Tags 2022**

Help your furry friend find their way home. By purchasing a dog tag, lost dogs can be easily identified to help reunite them with their owners. The cost of an annual dog tag is \$5 or purchase a life-time tag for your pooch for \$30.



**Do you have a Trailer you are using on your property?**

Did you know that Trailer By-law 2019-25 only permits trailers on properties zoned Rural Residential (RR), Agricultural (A) and Rural (RU) with a valid Trailer License? Annual trailer licenses are issued from May 1<sup>st</sup> to November 30<sup>th</sup> and are \$750. Monthly licenses can be purchased for \$150/month for a maximum of 3 months in a calendar year.



**From Public Works Superintendent Scott Edwards**

**WHAT ARE WE UP TO? FLUSHING CULVERTS**

Come Spring thaw, many culverts have ice buildup which blocks water flow. When the temperature drops overnight the water freezes blocking up the culvert reducing or restricting proper waterflow. The roads crew will be using a steamer designed to steam out the ice. This will ensure drainage and help avoid flooding.



**Not sure about Half Loads? Not sure if you need a Road Occupation Permit? Think You Have A Blocked Culvert? Any Other Public Works Questions?**

Contact Scott Edwards, Public Works Superintendent at (705) 349-3034 or by email at [sedwards@magnetawan.com](mailto:sedwards@magnetawan.com)



**From Fire Chief Joe Readman**

Did you know Magnetawan's Fire Department is **Volunteer**? We are always looking for new members and are now accepting applications to expand our department. Don't think you have the knowledge? No Problem! Magnetawan Fire provides you with all the required training with the goal of having all members fully Certified to the North American recognized National Fire Protection Association Standard. If you are a full-time resident, have a valid drivers license and are at least 18 years of age please contact Fire Chief Joe Readman at [fire@magnetawan.com](mailto:fire@magnetawan.com) or (705) 349-8477 for an application or to answer any questions you may have.



**We want to hear from you !! Ideas, questions, and/or opinions? Contact us at (705) 387-3947 or at [info@magnetawan.com](mailto:info@magnetawan.com) [www.magnetawan.com](http://www.magnetawan.com)**



**Witnessed Illegal Dumping? Please contact our By-law Officer Caitlin Deevey at (705) 497-4959**

**Violators will be guilty of a Provincial Offence, subject to a maximum penalty of \$5,000 and a day in court**

**LANDFILL HOURS**

**SUMMER - Begins Saturday of May Long Weekend**

**Landfills regularly scheduled to be OPEN during the Summer will be OPEN on Statutory Holidays**

**CHAPMAN SITE 259 Rocky Road  
8am to 4pm  
Sunday Monday Saturday**

**CROFT 218 25<sup>TH</sup> & 26<sup>TH</sup> Side Road  
8am to 4pm  
Sunday Tuesday Friday Saturday**

**WINTER - Begins Tuesday after Thanksgiving Weekend  
Closed all Statutory Holidays**

**CHAPMAN SITE 259 Rocky Road  
8am to 4pm  
Sunday Monday**

**CROFT 218 25<sup>TH</sup> & 26<sup>TH</sup> Side Road  
8am to 4pm  
Tuesday Friday Saturday**



**CAUTION  
Hazardous Material**

**HAZMAT DAY  
IS TENTATIVELY BOOKED FOR  
JULY, 2022  
WATCH FOR UPDATES FOR  
CONFIRMED DATE, TIME, AND  
LOCATION!**

**GREAT NEWS!  
WE ARE OPENING A RE-USE  
CENTRE AT THE CROFT  
LANDFILL SITE  
IN 2022!  
NEW Starting in 2022 BOTH  
LANDFILLS CAN ACCEPT  
DEBIT/INTERAC PAYMENTS!!!**

THE GREAT  
NORTHERN ONTARIO  
**ROADSHOW**



**THE GREAT NORTHERN  
ONTARIO ROADSHOW  
IS VISITING ALMAGUIN!**

JOIN US FOR A DAY FILLED WITH FUN ACTIVITIES,  
SCIENCE NORTH SCIENCE SHOWS,  
A LOCAL MARKET, AND MAKE MEMORIES  
WITH THE PEOPLE YOU CARE ABOUT!

[GNOR.SCIENCENORTH.CA](http://GNOR.SCIENCENORTH.CA)

**JOIN US AT THESE LOCATIONS:**

**SOUTH RIVER**  
MARCH 16TH  
12PM - 4PM  
SOUTH RIVER  
BREWING CO

**PERRY TOWNSHIP**  
MARCH 17TH  
12PM - 4PM  
NOVAR COMMUNITY  
CENTRE

**MAGNETAWAN**  
MARCH 18TH  
12PM - 4PM  
MAGNETAWAN  
COMMUNITY CENTRE

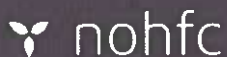

An Agency of  
the Government  
of Ontario

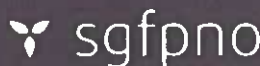

Un organisme  
du gouvernement  
de l'Ontario

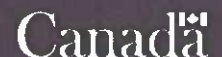

**NEW!**

**HOORAY!**

**EXCITING!**

**THE MUNICIPAL OFFICE WILL NOW BE  
OPEN 8AM TO 5PM  
MONDAY TO FRIDAY  
TO HELP SERVE **YOU** BETTER!**



**FOR MORE INFORMATION CONTACT US AT (705) 387-3947**

**OR AT [INFO@MAGNETAWAN.COM](mailto:INFO@MAGNETAWAN.COM)**





# ICYMI

## In Case You Missed It!

### Council Highlights

### February 09, 2022

To read the complete minutes, agenda packages and by-laws please visit our website at [www.magnetawan.com](http://www.magnetawan.com)

## Year of the Garden

### Année du jardin



Council passed resolution 2022-29 Proclaiming the Year of the Garden in 2022. The Year of the Garden 2022 is the Centennial Celebration of Canada's horticulture sector marked with the 100<sup>th</sup> Anniversary of the Canadian Nursery Landscape Association. From January 1 to December 31, 2022, we will commemorate and celebrate Canada's rich garden heritage, celebrate today's vibrant garden culture, and create legacies for a sustainable future. For more information or to subscribe to the newsletter visit their website at <https://livethegardenlife.gardenscanada.ca/> Watch for updates on community events in celebration!

Council passed resolution 2022-33 authorizing the donation of \$500 to the Almaguin Community Hatchery Program. The Almaguin Community Hatchery Program is a group of volunteers have been in existence for over 30 years. The Hatchery in order to continue their great work needs to purchase high tech equipment to monitor in real time, water levels, water flow rates, oxygen levels, PH levels, ammonia levels, temperatures, all via sensors, camera, computer equipment and software programs. For more information on the Almaguin Community Hatchery Program or to donate visit their website at <https://almaguinhatchery.com/>

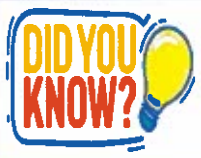

That there are multiple ways to pay your tax bill? Instructions are posted up on our website under our RESIDENTS Page! Municipal Staff are currently preparing the first installment of the 2022 tax bills to be mailed out in the upcoming weeks

**SAVE THE DATE**

The next meeting of Council is March 2, 2022, at 1:00 pm at the Magnetawan Community Centre

Questions? Concerns? Ideas? Contact the Municipal Office at (705) 387-3947 or by email at [info@magnetawan.com](mailto:info@magnetawan.com)

Council Approval Accounts Payable and Payroll

Meeting Date: March 2/22

| Accounts Payable                                                                               | Amount        |
|------------------------------------------------------------------------------------------------|---------------|
| Batch # 11<br>Cheque Date: 04/02/22<br>Cheque Numbers<br>From: 22606 To: 22606                 | \$ 471.50     |
| Batch # 15<br>Cheque Date: 02/03/22<br>From: 22610 To: 22609                                   | \$ 212,102.29 |
| EFT<br>Batch # 17                                                                              | \$ 33,151.80  |
| EFT<br>Batch #                                                                                 | \$            |
| Total Accounts Payable                                                                         | \$ 245,725.59 |
| Cancelled Cheques 22398                                                                        | (471.50)      |
| <b>Payroll</b>                                                                                 |               |
| Staff Pay<br>Pay Period: # 3<br>Direct deposit and<br>Cheque # 22604 to # 22607<br>22605 22608 | \$ 39,541.07  |
| Staff Pay<br>Pay Period: # 4<br>Direct deposit and<br>Cheque # 22609 to # 22609                | \$ 39,260.71  |
| Council Pay<br>Pay Period: #<br>All Direct deposit                                             | \$            |
| Total Payroll                                                                                  | \$ 78,801.78  |
| Total for Resolution                                                                           | \$ 324,055.87 |

**MUNICIPALITY OF MAGNETAWAN**  
**Council/Board Report By Dept-(Computer)**

AP5130 Page : 1  
 Date : Feb 24, 2022 Time : 4:05 pm

Vendor : 01009 To 30000  
 Batch : 11 To 11  
 Department : All

Cheque Print Date : 01-Jan-2021 To 02-Mar-2022  
 Bank : 0099 To 1  
 Class : All

| Vendor Invoice | Vendor Name Description     | Batch | Inv Date | Inv Due Date | Amount |
|----------------|-----------------------------|-------|----------|--------------|--------|
| G.L. Account   | CC1 CC2 CC3 GL Account Name |       |          |              |        |

DEPARTMENT 1200 ADMINISTRATION

01024 ADJUSTERS SSA LIMITED

22/085 LEGAL - COLACO

1-4-1200-2210

ADMIN - Legal Fees-general

11 25-Nov-2021 04-Feb-2022

471.50

Department Totals : 471.50

Computer Paid Total : 471.50

Total Unpaid for Approval : 0.00  
 Total Manually Paid for Approval : 0.00  
 Total Computer Paid for Approval : 471.50  
 Total EFT Paid for Approval : 0.00  
 Grand Total ITEMS for Approval : 471.50

BATCH 11

**MUNICIPALITY OF MAGNETAWAN**  
**Council/Board Report By Dept-(Computer)**

AP5130

Page : 1

Date : Feb 24, 2022

Time : 4:04 pm

Vendor : 01009 To 30000  
 Batch : 15 To 15  
 Department : All

Cheque Print Date : 24-Feb-2022 To 02-Mar-2022  
 Bank : 0099 To 1  
 Class : All

| Vendor Invoice                     | Vendor Name Description                        | Batch | Inv Date    | Inv Due Date | Amount    |
|------------------------------------|------------------------------------------------|-------|-------------|--------------|-----------|
| G.L. Account                       | CC1 CC2 CC3 GL Account Name                    |       |             |              |           |
| <b>DEPARTMENT 1000 LEGISLATIVE</b> |                                                |       |             |              |           |
| <b>01038</b>                       | <b>ALMAGUIN COMMUNITY HATCHERY PROGRAM C/O</b> |       |             |              |           |
| 2022-33                            | DONATION                                       | 15    | 09-Feb-2022 | 02-Mar-2022  |           |
| 1-4-1000-5018                      | COUNCIL - Donations                            |       |             |              | 500.00    |
| <b>02037</b>                       | <b>BRAY MOTORS LIMITED</b>                     |       |             |              |           |
| 5588                               | OIL CHANGE AND BREAK CHECK                     | 15    | 31-Dec-2021 | 02-Mar-2022  |           |
| 1-2-1000-1009                      | Accounts Payable - Clearing account            |       |             |              | 374.13    |
| <b>04021</b>                       | <b>DEAN'S AUTO CARE</b>                        |       |             |              |           |
| 15964                              | FILTERS AND OIL FOR TRUCK 11                   | 15    | 24-Nov-2021 | 02-Mar-2022  |           |
| 1-2-1000-1009                      | Accounts Payable - Clearing account            |       |             |              | 36.12     |
| 1-2-1000-1009                      | Accounts Payable - Clearing account            |       |             |              | 36.12     |
| <b>08084</b>                       | <b>HUBB CAP</b>                                |       |             |              |           |
| 1023751                            | PARTS RETURNED                                 | 15    | 24-Feb-2021 | 02-Mar-2022  |           |
| 1-2-1000-1009                      | Accounts Payable - Clearing account            |       |             |              | -1,558.18 |
| 1027582                            | SNOW PLOW PARTS                                | 15    | 30-Nov-2021 | 02-Mar-2022  |           |
| 1-2-1000-1009                      | Accounts Payable - Clearing account            |       |             |              | 2,611.88  |
| <b>13021</b>                       | <b>MAP SUNDRIDGE</b>                           |       |             |              |           |
| F76589                             | INVOICE K62005/3 OVERPAYMENT CREDIT            | 15    | 23-Jul-2018 | 02-Mar-2022  |           |
| 1-2-1000-1009                      | Accounts Payable - Clearing account            |       |             |              | -38.33    |
| G87875                             | INVOICE 690018 OVERPAYMENT CREDIT              | 15    | 02-Dec-2020 | 02-Mar-2022  |           |
| 1-2-1000-1009                      | Accounts Payable - Clearing account            |       |             |              | -141.86   |
| H40023                             | INVOICE 558462 OVERPAYMENT CREDIT              | 15    | 16-Apr-2018 | 02-Mar-2022  |           |
| 1-2-1000-1009                      | Accounts Payable - Clearing account            |       |             |              | -33.06    |
| <b>13073</b>                       | <b>MINISTER OF FINANCE</b>                     |       |             |              |           |
| 282401221455                       | DECEMBER 2021 OPP BILLING                      | 15    | 31-Jan-2022 | 02-Mar-2022  |           |
| 1-2-1000-1009                      | Accounts Payable - Clearing account            |       |             |              | 40,641.00 |
| <b>13095</b>                       | <b>MICALLEF STEVE</b>                          |       |             |              |           |
| 2004-12                            | REFUND FOR ENTRANCE PERMIT DEPOSIT             | 15    | 23-Feb-2022 | 02-Mar-2022  |           |
| 1-2-1000-1083                      | Entrance Security Deposits                     |       |             |              | 500.00    |
| <b>13229</b>                       | <b>A MIRON TOPSOIL LTD</b>                     |       |             |              |           |
| 21/22                              | RETURN WINTER SAND TENDER DEPOSIT              | 15    | 08-Feb-2022 | 02-Mar-2022  |           |
| 1-2-1000-1086                      | Tender Deposits                                |       |             |              | 6,573.77  |
| <b>13334</b>                       | <b>M&amp;L SUPPLY FIRE &amp; SAFETY</b>        |       |             |              |           |
| 009663                             | FIRE SAFETY BOOTS                              | 15    | 14-Oct-2021 | 02-Mar-2022  |           |
| 1-2-1000-1009                      | Accounts Payable - Clearing account            |       |             |              | 5,698.00  |
| 009849                             | SAFETY CLOTHING                                | 15    | 08-Nov-2021 | 02-Mar-2022  |           |
| 1-2-1000-1009                      | Accounts Payable - Clearing account            |       |             |              | 886.54    |
| 010718                             | FIRE SAFETY BOOTS                              | 15    | 31-Dec-2021 | 02-Mar-2022  |           |
| 1-2-1000-1009                      | Accounts Payable - Clearing account            |       |             |              | 263.18    |
| <b>16235</b>                       | <b>THE PUBLIC SECTOR DIGEST INC.</b>           |       |             |              |           |
| 16423                              | INVOICE #5 INSTALLMENT FOR AMP                 | 15    | 31-Jan-2022 | 02-Mar-2022  |           |
| 1-2-1000-1009                      | Accounts Payable - Clearing account            |       |             |              | 7,345.00  |
| <b>18035</b>                       | <b>RUSSELL</b>                                 |       |             |              |           |
| 63-283-394                         | MUNN-SAUNDERS SITE PLAN AGREEMENT              | 15    | 09-Feb-2022 | 02-Mar-2022  |           |
| 1-2-1000-1009                      | Accounts Payable - Clearing account            |       |             |              | 534.65    |
| 63-283-397                         | WAKELY SITE PLAN AGREEMENT                     | 15    | 09-Feb-2022 | 02-Mar-2022  |           |
| 1-2-1000-1009                      | Accounts Payable - Clearing account            |       |             |              | 462.08    |



**MUNICIPALITY OF MAGNETAWAN**  
**Council/Board Report By Dept-(Computer)**

AP5130

Page : 2

Date : Feb 24, 2022

Time : 4.04 pm

Vendor : 01009 To 30000  
 Batch : 15 To 15  
 Department : All

Cheque Print Date : 24-Feb-2022 To 02-Mar-2022  
 Bank : 0099 To 1  
 Class : All

| Vendor Invoice                     | Vendor Name Description              | Batch | Inv Date    | Inv Due Date | Amount           |
|------------------------------------|--------------------------------------|-------|-------------|--------------|------------------|
| G.L. Account                       | CC1 CC2 CC3 GL Account Name          |       |             |              |                  |
| <b>DEPARTMENT 1000 LEGISLATIVE</b> |                                      |       |             |              |                  |
| <b>19055</b>                       | <b>STAPLES BUSINESS ADVANTAGE</b>    |       |             |              |                  |
| 55323996                           | ADDRESS LABELS FOR LANDFILL MAIL OUT | 15    | 01-Feb-2021 | 02-Mar-2022  |                  |
| 1-2-1000-1009                      | Accounts Payable - Clearing account  |       |             |              | 120.07           |
| 55423917                           | SUPPLIES                             | 15    | 11-Feb-2021 | 02-Mar-2022  |                  |
| 1-2-1000-1009                      | Accounts Payable - Clearing account  |       |             |              | 35.32            |
| 56457950                           | CLIP BOARDS                          | 15    | 21-Jun-2021 | 02-Mar-2022  |                  |
| 1-2-1000-1009                      | Accounts Payable - Clearing account  |       |             |              | 5.13             |
| 56478679                           | SUPPLIES                             | 15    | 23-Jun-2021 | 02-Mar-2022  |                  |
| 1-2-1000-1009                      | Accounts Payable - Clearing account  |       |             |              | 83.41            |
| 56523571                           | SUPPLIES                             | 15    | 29-Jun-2021 | 02-Mar-2022  |                  |
| 1-2-1000-1009                      | Accounts Payable - Clearing account  |       |             |              | 103.61           |
| 56565447                           | SUPPLIES                             | 15    | 06-Jul-2021 | 02-Mar-2022  |                  |
| 1-2-1000-1009                      | Accounts Payable - Clearing account  |       |             |              | 12.99            |
| 56570767                           | MONITOR                              | 15    | 06-Jul-2021 | 02-Mar-2022  |                  |
| 1-2-1000-1009                      | Accounts Payable - Clearing account  |       |             |              | 312.50           |
| 56636745                           | PAPER AND SUPPLIES                   | 15    | 15-Jul-2021 | 02-Mar-2022  |                  |
| 1-2-1000-1009                      | Accounts Payable - Clearing account  |       |             |              | 229.28           |
| 56650646                           | SUPPLIES                             | 15    | 19-Jul-2021 | 02-Mar-2022  |                  |
| 1-2-1000-1009                      | Accounts Payable - Clearing account  |       |             |              | 75.32            |
| <b>19145</b>                       | <b>SIGNCRAFT CANADA INC.</b>         |       |             |              |                  |
| 1334                               | PUBLIC WORKS - EXIT ONLY SIGN        | 15    | 09-Oct-2021 | 02-Mar-2022  |                  |
| 1-2-1000-1009                      | Accounts Payable - Clearing account  |       |             |              | 175.15           |
| 1431                               | PARKS DEPT. - NO PARKING SIGN        | 15    | 26-Nov-2021 | 02-Mar-2022  |                  |
| 1-2-1000-1009                      | Accounts Payable - Clearing account  |       |             |              | 197.75           |
| <b>Department Totals :</b>         |                                      |       |             |              | <b>66,041.57</b> |

|                                            |                           |    |             |             |                 |
|--------------------------------------------|---------------------------|----|-------------|-------------|-----------------|
| <b>DEPARTMENT 1100 ACCOUNTS RECEIVABLE</b> |                           |    |             |             |                 |
| <b>19045</b>                               | <b>LINDA SAUNDERS</b>     |    |             |             |                 |
| 2022                                       | REFUND BALANCE OF DEPOSIT | 15 | 14-Feb-2022 | 02-Mar-2022 |                 |
| 1-1-1100-1151                              | A/R-Munn                  |    |             |             | 1,231.54        |
| <b>Department Totals :</b>                 |                           |    |             |             | <b>1,231.54</b> |

|                                       |                                               |    |             |             |          |
|---------------------------------------|-----------------------------------------------|----|-------------|-------------|----------|
| <b>DEPARTMENT 1200 ADMINISTRATION</b> |                                               |    |             |             |          |
| <b>03062</b>                          | <b>CENTURY 21 BLUE SKY REGION REALTY IN</b>   |    |             |             |          |
| FEB/2022                              | LETTER OF OPINION OF VALUES                   | 15 | 17-Feb-2022 | 02-Mar-2022 |          |
| 1-4-1200-2010                         | ADMIN - Office & Maintenance Supplies         |    |             |             | 565.00   |
| <b>03087</b>                          | <b>CENTRALSQUARE CANADA SOFTWARE INC.</b>     |    |             |             |          |
| 345500                                | VADIM KIT ASSISTS                             | 15 | 03-Feb-2022 | 02-Mar-2022 |          |
| 1-4-1200-2130                         | ADMIN - Computer expenses                     |    |             |             | 2,672.45 |
| <b>03184</b>                          | <b>COMPUTER TECH CD</b>                       |    |             |             |          |
| 1870                                  | FEB 15 - MAR 15/22 MONTHLY SERVER MAINTENANCE | 15 | 15-Feb-2022 | 02-Mar-2022 |          |
| 1-4-1200-2130                         | ADMIN - Computer expenses                     |    |             |             | 301.71   |
| <b>19055</b>                          | <b>STAPLES BUSINESS ADVANTAGE</b>             |    |             |             |          |
| 58393262                              | SUPPLIES                                      | 15 | 01-Feb-2022 | 02-Mar-2022 |          |
| 1-4-1200-2010                         | ADMIN - Office & Maintenance Supplies         |    |             |             | 103.08   |
| 58433181                              | OFFICE SUPPLIES                               | 15 | 03-Feb-2022 | 02-Mar-2022 |          |

**MUNICIPALITY OF MAGNETAWAN**  
**Council/Board Report By Dept-(Computer)**

AP5130

Page : 3

Date : Feb 24, 2022

Time : 4:04 pm

Vendor : 01009 To 30000  
 Batch : 15 To 15  
 Department : All

Cheque Print Date : 24-Feb-2022 To 02-Mar-2022  
 Bank : 0099 To 1  
 Class : All

| Vendor Invoice                          | Vendor Name Description               | Batch | Inv Date    | Inv Due Date | Amount          |
|-----------------------------------------|---------------------------------------|-------|-------------|--------------|-----------------|
| G.L. Account                            | CC1 CC2 CC3 GL Account Name           |       |             |              |                 |
| <b>DEPARTMENT 1200 ADMINISTRATION</b>   |                                       |       |             |              |                 |
| 1-4-1200-2010                           | ADMIN - Office & Maintenance Supplies |       |             |              | 99.85           |
| 58555828                                | TONER                                 | 15    | 16-Feb-2022 | 02-Mar-2022  | 56.49           |
| 1-4-1200-2010                           | ADMIN - Office & Maintenance Supplies |       |             |              |                 |
| <b>19083 SELECTCOM</b>                  |                                       |       |             |              |                 |
| 0005020938                              | LONG DISTANCE CHARGES                 | 15    | 01-Feb-2022 | 02-Mar-2022  | 623.97          |
| 1-4-1200-2050                           | ADMIN - Telephone                     |       |             |              |                 |
| <b>22030 VIA NET INTERNET SOLUTIONS</b> |                                       |       |             |              |                 |
| FEB/22                                  | MONTHLY INTERNET SERVICES             | 15    | 01-Feb-2022 | 02-Mar-2022  | 230.50          |
| 1-4-1200-2135                           | ADMIN - Website expenses              |       |             |              |                 |
| <b>23086 XEROX CANADA LTD</b>           |                                       |       |             |              |                 |
| 85532404                                | JAN/22 COPYING EXPENSES               | 15    | 01-Feb-2022 | 02-Mar-2022  | 328.68          |
| 1-4-1200-2140                           | ADMIN - Copying Expenses              |       |             |              |                 |
| <b>Department Totals :</b>              |                                       |       |             |              | <b>4,981.73</b> |

|                                             |                                        |    |             |             |               |
|---------------------------------------------|----------------------------------------|----|-------------|-------------|---------------|
| <b>DEPARTMENT 2000 FIRE DEPARTMENT</b>      |                                        |    |             |             |               |
| <b>01186 ANNEX PUBLISHING BOOK DIVISION</b> |                                        |    |             |             |               |
| BK0009143                                   | TEXT BOOKS                             | 15 | 27-Jan-2022 | 02-Mar-2022 | 752.24        |
| 1-4-2000-1410                               | FD - Volunteer Training Expenses       |    |             |             |               |
| <b>02014 BELL MOBILITY INC</b>              |                                        |    |             |             |               |
| 0095813466                                  | FEB/22 CELL TOWER RENTAL               | 15 | 01-Feb-2022 | 02-Mar-2022 | 66.50         |
| 1-4-2000-2053                               | FD - Communications Tower              |    |             |             |               |
| <b>15050 HYDRO ONE NETWORKS</b>             |                                        |    |             |             |               |
| 200198935146                                | 226 SIDE RD 15/16                      | 15 | 31-Jan-2022 | 02-Mar-2022 | 33.98         |
| 1-4-2000-2029                               | FD - Hydro - 226 15th & 16th Side Rd N |    |             |             |               |
| <b>Department Totals :</b>                  |                                        |    |             |             | <b>852.72</b> |

|                                         |                                          |    |             |             |               |
|-----------------------------------------|------------------------------------------|----|-------------|-------------|---------------|
| <b>DEPARTMENT 2005 FIRE MAG STATION</b> |                                          |    |             |             |               |
| <b>06048 FIRE-ALERT</b>                 |                                          |    |             |             |               |
| 7669                                    | ANNUAL EXTINGUISHER/EMERGENCY INSPECTION | 15 | 11-Jan-2022 | 02-Mar-2022 | 418.04        |
| 1-4-2005-7140                           | MAG STATION - Maintenance & Repairs      |    |             |             |               |
| <b>Department Totals :</b>              |                                          |    |             |             | <b>418.04</b> |

|                                           |                       |    |             |             |              |
|-------------------------------------------|-----------------------|----|-------------|-------------|--------------|
| <b>DEPARTMENT 2006 FIRE AHMIC STATION</b> |                       |    |             |             |              |
| <b>15050 HYDRO ONE NETWORKS</b>           |                       |    |             |             |              |
| 200198932621                              | 60 AHMIC STREET       | 15 | 01-Feb-2022 | 02-Mar-2022 | 65.16        |
| 1-4-2006-2030                             | AHMIC STATION - Hydro |    |             |             |              |
| <b>Department Totals :</b>                |                       |    |             |             | <b>65.16</b> |

|                                                        |                                                   |    |             |             |        |
|--------------------------------------------------------|---------------------------------------------------|----|-------------|-------------|--------|
| <b>DEPARTMENT 2100 BUILDING REVENUES</b>               |                                                   |    |             |             |        |
| <b>030007 HARDY NIEMI LAW PROFESSIONAL CORPORATION</b> |                                                   |    |             |             |        |
| 2022                                                   | PROPERTY INFORMATION REPORT NOT REQUIRED - REFUND | 15 | 22-Feb-2022 | 02-Mar-2022 | 175.15 |
| 1-3-2100-7210                                          | CBO - Building Information Reports                |    |             |             |        |
| <b>04006 HALL DEBBIE ANN</b>                           |                                                   |    |             |             |        |
| 0001272                                                | BUILDING PARALEGAL SERVICES                       | 15 | 08-Feb-2022 | 02-Mar-2022 | 508.52 |
| 1-4-2100-2210                                          | CBO - Legal Fees                                  |    |             |             |        |

**MUNICIPALITY OF MAGNETAWAN**  
**Council/Board Report By Dept-(Computer)**

AP5130 Page : 4  
 Date : Feb 24, 2022 Time : 4:04 pm

Vendor : 01009 To 30000  
 Batch : 15 To 15  
 Department : All

Cheque Print Date : 24-Feb-2022 To 02-Mar-2022  
 Bank : 0099 To 1  
 Class : All

| Vendor Invoice                                              | Vendor Name Description                                 | Batch | Inv Date       | Inv Due Date | Amount          |
|-------------------------------------------------------------|---------------------------------------------------------|-------|----------------|--------------|-----------------|
| G.L. Account                                                | CC1 CC2 CC3 GL Account Name                             |       |                |              |                 |
| <b>DEPARTMENT 2100 BUILDING REVENUES</b>                    |                                                         |       |                |              |                 |
| 15008                                                       | ONTARIO BUILDING OFFICIALS ASSOCIATION                  |       |                |              |                 |
| 2022                                                        | OBOA 2022 MEMBERSHIP FEE                                |       | 15 22-Feb-2022 | 02-Mar-2022  |                 |
| 1-4-2100-1320                                               | CBO - Memberships                                       |       |                |              | 30.00           |
| 19055                                                       | STAPLES BUSINESS ADVANTAGE                              |       |                |              |                 |
| 58447978                                                    | MONITOR WALL MOUNT                                      |       | 15 04-Feb-2022 | 02-Mar-2022  |                 |
| 1-4-2100-2010                                               | CBO - Materials/Supplies                                |       |                |              | 169.49          |
| 58552339                                                    | SUPPLIES                                                |       | 15 15-Feb-2022 | 02-Mar-2022  |                 |
| 1-4-2100-2010                                               | CBO - Materials/Supplies                                |       |                |              | 16.36           |
| 58585679                                                    | 20FT HDMI                                               |       | 15 17-Feb-2022 | 02-Mar-2022  |                 |
| 1-4-2100-2010                                               | CBO - Materials/Supplies                                |       |                |              | 45.19           |
| 20083                                                       | TRACKMATICS INC                                         |       |                |              |                 |
| 38266                                                       | MONTHLY GPS TRACKING - BUILDING DEPT.                   |       | 15 05-Feb-2022 | 02-Mar-2022  |                 |
| 1-4-2100-2010                                               | CBO - Materials/Supplies                                |       |                |              | 39.55           |
| <b>Department Totals :</b>                                  |                                                         |       |                |              | <b>984.26</b>   |
| <hr/>                                                       |                                                         |       |                |              |                 |
| <b>DEPARTMENT 2200 BYLAW ENFORCEMENT</b>                    |                                                         |       |                |              |                 |
| 04031                                                       | DEEVEY CAITLIN A                                        |       |                |              |                 |
| M00000376                                                   | JAN 24 - FEB 3/22 MILEAGE AND CELL PHONE                |       | 15 07-Feb-2022 | 02-Mar-2022  |                 |
| 1-4-2200-2025                                               | BLEO - Mileage                                          |       |                |              | 260.47          |
| 1-4-2200-2010                                               | BLEO - Materials/Supplies                               |       |                |              | 20.00           |
| 15083                                                       | ONTARIO SPCA AND HUMANE SOCIETY                         |       |                |              |                 |
| 008885                                                      | ANIMAL CONTROL FEES JAN 1 - MAR 31/22                   |       | 15 31-Jan-2022 | 02-Mar-2022  |                 |
| 1-4-2200-2016                                               | BLEO - Animal Control Expenses                          |       |                |              | 92.20           |
| <b>Department Totals :</b>                                  |                                                         |       |                |              | <b>372.67</b>   |
| <hr/>                                                       |                                                         |       |                |              |                 |
| <b>DEPARTMENT 2500 PROTECTION TO PERSONS &amp; PROPERTY</b> |                                                         |       |                |              |                 |
| 13084                                                       | MINISTER OF FINANCE                                     |       |                |              |                 |
| 282701221345                                                | MUNICIPAL POLICING - ANNUAL BILLING (JAN 1 - DEC 31/22) |       | 15 27-Jan-2022 | 02-Mar-2022  |                 |
| 1-4-2500-2030                                               | PROTECT - 911                                           |       |                |              | 671.52          |
| <b>Department Totals :</b>                                  |                                                         |       |                |              | <b>671.52</b>   |
| <hr/>                                                       |                                                         |       |                |              |                 |
| <b>DEPARTMENT 3036 DRAINAGE</b>                             |                                                         |       |                |              |                 |
| 17001                                                       | R&R LOGGING AND CONSTRUCTION LTD                        |       |                |              |                 |
| FEB 4/22                                                    | CLEANED UP DOWN TREES WEEK OF JAN 3/22                  |       | 15 04-Feb-2022 | 02-Mar-2022  |                 |
| 1-4-3036-4010                                               | C6 - Contracts                                          |       |                |              | 3,729.00        |
| <b>Department Totals :</b>                                  |                                                         |       |                |              | <b>3,729.00</b> |
| <hr/>                                                       |                                                         |       |                |              |                 |
| <b>DEPARTMENT 3051 SNOW PLOWING</b>                         |                                                         |       |                |              |                 |
| 01076                                                       | ALLISTON EQUIPMENT LTD                                  |       |                |              |                 |
| 16168                                                       | TANDEM HYDRAULIC PUMP AND JOY STICK                     |       | 15 04-Feb-2022 | 02-Mar-2022  |                 |
| 1-4-3051-2010                                               | E1 - Materials/Supplies                                 |       |                |              | 2,884.50        |
| 07064                                                       | GIN-COR INDUSTRIES                                      |       |                |              |                 |
| 71251                                                       | SNOW PLOW - BEARING FLANGE                              |       | 15 31-Jan-2022 | 02-Mar-2022  |                 |
| 1-4-3051-2010                                               | E1 - Materials/Supplies                                 |       |                |              | 125.99          |
| <b>Department Totals :</b>                                  |                                                         |       |                |              | <b>3,010.49</b> |

**MUNICIPALITY OF MAGNETAWAN**  
**Council/Board Report By Dept-(Computer)**

AP5130 Page : 5  
 Date : Feb 24, 2022 Time : 4:04 pm

Vendor : 01009 To 30000  
 Batch : 15 To 15  
 Department : All

Cheque Print Date : 24-Feb-2022 To 02-Mar-2022  
 Bank : 0099 To 1  
 Class : All

| Vendor Invoice                        | Vendor Name Description                                     | Batch | Inv Date       | Inv Due Date | Amount        |
|---------------------------------------|-------------------------------------------------------------|-------|----------------|--------------|---------------|
| G.L. Account                          | CC1 CC2 CC3 GL Account Name                                 |       |                |              |               |
| <b>DEPARTMENT 3051 SNOW PLOWING</b>   |                                                             |       |                |              |               |
| <b>DEPARTMENT 3061 SAFETY DEVICES</b> |                                                             |       |                |              |               |
| 19037                                 | SLING-CHOKER MFG. (NORTH BAY) LTD.                          |       |                |              |               |
| 91513                                 | PUBLIC WORKS SAFETY CLOTHING                                |       | 15 31-Jan-2022 | 02-Mar-2022  |               |
| 1-4-3061-2020                         | F - Safety-PPE                                              |       |                |              | 223.07        |
| <b>Department Totals :</b>            |                                                             |       |                |              | <b>223.07</b> |
| <b>DEPARTMENT 3101 OVERHEAD</b>       |                                                             |       |                |              |               |
| 01184                                 | AHMIC MARINE LTD.                                           |       |                |              |               |
| 2022-020                              | OIL AND FILTER CHANGE FOR GENERAC - PUBLIC WORKS            |       | 15 31-Jan-2022 | 02-Mar-2022  |               |
| 1-4-3101-2400                         | J - Building Maintenance                                    |       |                |              | 205.64        |
| 02014                                 | BELL MOBILITY INC                                           |       |                |              |               |
| 0095813466                            | FEB/22 CELL TOWER RENTAL                                    |       | 15 01-Feb-2022 | 02-Mar-2022  |               |
| 1-4-3101-2053                         | J - Communications Equipment and Tower                      |       |                |              | 66.50         |
| 03116                                 | CANADA FASTENAL LTD                                         |       |                |              |               |
| ONHUN78539                            | GREASE GUN KIT                                              |       | 15 31-Jan-2022 | 02-Mar-2022  |               |
| 1-4-3101-2080                         | J - Small Tools and Supplies                                |       |                |              | 528.83        |
| 13012                                 | MAGNETAWAN BUILDING CENTRE (ROADS)                          |       |                |              |               |
| 101-84897                             | SUPPLIES                                                    |       | 15 10-Feb-2022 | 02-Mar-2022  |               |
| 1-4-3101-2010                         | J - Materials/Supplies                                      |       |                |              | 36.14         |
| 103-87702                             | SUPPLIES                                                    |       | 15 04-Feb-2022 | 02-Mar-2022  |               |
| 1-4-3101-2080                         | J - Small Tools and Supplies                                |       |                |              | 73.38         |
| 13021                                 | MAP SUNDRIDGE                                               |       |                |              |               |
| 755366/3                              | SUPPLIES                                                    |       | 15 11-Feb-2022 | 02-Mar-2022  |               |
| 1-4-3101-2010                         | J - Materials/Supplies                                      |       |                |              | 33.70         |
| 13086                                 | MINUTEMAN PRESS                                             |       |                |              |               |
| 18742                                 | 40 MOTOR VEHICLE INSPECTION PAD & 50 INSPECTION REPORT PADS |       | 15 09-Feb-2022 | 02-Mar-2022  |               |
| 1-4-3101-2120                         | J - Office                                                  |       |                |              | 715.34        |
| 13087                                 | MESSER CANADA INC                                           |       |                |              |               |
| 2104745480                            | SUPPLIES                                                    |       | 15 09-Feb-2022 | 02-Mar-2022  |               |
| 1-4-3101-2080                         | J - Small Tools and Supplies                                |       |                |              | 154.70        |
| 13240                                 | JIM MOORE PETROLEUM                                         |       |                |              |               |
| 587293                                | CLEAR DIESEL                                                |       | 15 19-Jan-2022 | 02-Mar-2022  |               |
| 1-4-3101-2022                         | J - Clear Diesel Inventory Clearing                         |       |                |              | 1,882.29      |
| 587294                                | DYED DIESEL                                                 |       | 15 19-Jan-2022 | 02-Mar-2022  |               |
| 1-4-3101-2023                         | J - Dyed Diesel Inventory Clearing                          |       |                |              | 360.93        |
| 587295                                | PREMIUM GASOLINE                                            |       | 15 19-Jan-2022 | 02-Mar-2022  |               |
| 1-4-3101-2021                         | J - Premium Gasoline Inventory Clearing                     |       |                |              | 1,013.53      |
| 587882                                | CLEAR DIESEL                                                |       | 15 27-Jan-2022 | 02-Mar-2022  |               |
| 1-4-3101-2022                         | J - Clear Diesel Inventory Clearing                         |       |                |              | 4,357.07      |
| 587884                                | DYED DIESEL                                                 |       | 15 27-Jan-2022 | 02-Mar-2022  |               |
| 1-4-3101-2023                         | J - Dyed Diesel Inventory Clearing                          |       |                |              | 939.58        |
| 588817                                | CLEAR DIESEL                                                |       | 15 03-Feb-2022 | 02-Mar-2022  |               |
| 1-4-3101-2022                         | J - Clear Diesel Inventory Clearing                         |       |                |              | 3,078.61      |
| 588818                                | DYED DIESEL                                                 |       | 15 03-Feb-2022 | 02-Mar-2022  |               |
| 1-4-3101-2023                         | J - Dyed Diesel Inventory Clearing                          |       |                |              | 691.56        |
| 588836                                | PREMIUM GASOLINE                                            |       | 15 03-Feb-2022 | 02-Mar-2022  |               |

**MUNICIPALITY OF MAGNETAWAN**  
**Council/Board Report By Dept-(Computer)**

AP5130 Page : 6  
 Date : Feb 24, 2022 Time : 4:04 pm

Vendor : 01009 To 30000  
 Batch : 15 To 15  
 Department : All

Cheque Print Date : 24-Feb-2022 To 02-Mar-2022  
 Bank : 0099 To 1  
 Class : All

| Vendor Invoice                                  | Vendor Name Description                 | Batch | Inv Date    | Inv Due Date | Amount           |
|-------------------------------------------------|-----------------------------------------|-------|-------------|--------------|------------------|
| G.L. Account                                    | CC1 CC2 CC3 GL Account Name             |       |             |              |                  |
| <b>DEPARTMENT 3101 OVERHEAD</b>                 |                                         |       |             |              |                  |
| 1-4-3101-2021                                   | J - Premium Gasoline Inventory Clearing |       |             |              | 1,290.21         |
| <b>14062 NEAR NORTH INDUSTRIAL SOLUTIONS</b>    |                                         |       |             |              |                  |
| 77681                                           | WEICONLOCK RED LOCK PEN-SYSTEM          | 15    | 24-Jan-2022 | 02-Mar-2022  |                  |
| 1-4-3101-2010                                   | J - Materials/Supplies                  |       |             |              | 27.69            |
| 77808                                           | SUPPLIES                                | 15    | 01-Feb-2022 | 02-Mar-2022  |                  |
| 1-4-3101-2010                                   | J - Materials/Supplies                  |       |             |              | 5.88             |
| 77922                                           | SUPPLIES                                | 15    | 09-Feb-2022 | 02-Mar-2022  |                  |
| 1-4-3101-2010                                   | J - Materials/Supplies                  |       |             |              | 52.10            |
| <b>15050 HYDRO ONE NETWORKS</b>                 |                                         |       |             |              |                  |
| 200032498809                                    | 18 MILLER ROAD NEW GARAGE               | 15    | 24-Jan-2022 | 02-Mar-2022  |                  |
| 1-4-3101-2030                                   | J - Hydro                               |       |             |              | 622.46           |
| <b>18008 RED STALLION</b>                       |                                         |       |             |              |                  |
| 00532                                           | SUPPLIES                                | 15    | 08-Feb-2022 | 02-Mar-2022  |                  |
| 1-4-3101-2010                                   | J - Materials/Supplies                  |       |             |              | 403.09           |
| <b>19037 SLING-CHOKER MFG. (NORTH BAY) LTD.</b> |                                         |       |             |              |                  |
| 91702                                           | BOOSTER CABLES                          | 15    | 11-Feb-2022 | 02-Mar-2022  |                  |
| 1-4-3101-2010                                   | J - Materials/Supplies                  |       |             |              | 96.04            |
| <b>19055 STAPLES BUSINESS ADVANTAGE</b>         |                                         |       |             |              |                  |
| 58433181                                        | OFFICE SUPPLIES                         | 15    | 03-Feb-2022 | 02-Mar-2022  |                  |
| 1-4-3101-2120                                   | J - Office                              |       |             |              | 17.84            |
| 58552339                                        | SUPPLIES                                | 15    | 15-Feb-2022 | 02-Mar-2022  |                  |
| 1-4-3101-2120                                   | J - Office                              |       |             |              | 150.41           |
| <b>20083 TRACKMATICS INC</b>                    |                                         |       |             |              |                  |
| 38299                                           | MONTHLY GPS MONITORING - PUBLIC WORKS   | 15    | 05-Feb-2022 | 02-Mar-2022  |                  |
| 1-4-3101-2045                                   | J - GPS monitoring and data             |       |             |              | 501.72           |
| <b>Department Totals :</b>                      |                                         |       |             |              | <b>17,305.24</b> |

|                                                     |                             |    |             |             |               |
|-----------------------------------------------------|-----------------------------|----|-------------|-------------|---------------|
| <b>DEPARTMENT 3213 COMPACTOR - 2003 CATERPILLAR</b> |                             |    |             |             |               |
| <b>01033 AGRICULTURE FORESTRY CONSTRUCTION INC</b>  |                             |    |             |             |               |
| 2364                                                | REPAIRS TO LANDFILL PACKER  | 15 | 02-Feb-2022 | 02-Mar-2022 |               |
| 1-4-3213-2070                                       | COM - Repairs & Maintenance |    |             |             | 113.00        |
| <b>Department Totals :</b>                          |                             |    |             |             | <b>113.00</b> |

|                                                        |                                      |    |             |             |                 |
|--------------------------------------------------------|--------------------------------------|----|-------------|-------------|-----------------|
| <b>DEPARTMENT 3216 BACK HOE #3 - 2005 CASE 580 4WD</b> |                                      |    |             |             |                 |
| <b>01033 AGRICULTURE FORESTRY CONSTRUCTION INC</b>     |                                      |    |             |             |                 |
| 2330                                                   | REPLACED BATTERY IN LANDFILL BACKHOE | 15 | 24-Jan-2022 | 02-Mar-2022 |                 |
| 1-4-3216-2070                                          | BH3 - Repairs & Maintenance          |    |             |             | 710.80          |
| 2351                                                   | REPAIRS TO LANDFILL BACKHOE          | 15 | 28-Jan-2022 | 02-Mar-2022 |                 |
| 1-4-3216-2070                                          | BH3 - Repairs & Maintenance          |    |             |             | 287.83          |
| <b>03321 CURRIE TRUCK CENTRE</b>                       |                                      |    |             |             |                 |
| 0567587P                                               | DEF FLUID                            | 15 | 28-Jan-2022 | 02-Mar-2022 |                 |
| 1-4-3216-2070                                          | BH3 - Repairs & Maintenance          |    |             |             | 240.12          |
| <b>Department Totals :</b>                             |                                      |    |             |             | <b>1,238.75</b> |

|                                                           |  |  |  |  |  |
|-----------------------------------------------------------|--|--|--|--|--|
| <b>DEPARTMENT 3217 BACK HOE #4 - 2012 JOHN DEERE 410J</b> |  |  |  |  |  |
| <b>01033 AGRICULTURE FORESTRY CONSTRUCTION INC</b>        |  |  |  |  |  |

**MUNICIPALITY OF MAGNETAWAN**  
**Council/Board Report By Dept-(Computer)**

AP5130

Page : 7

Date : Feb 24, 2022

Time : 4:04 pm

Vendor : 01009 To 30000  
 Batch : 15 To 15  
 Department : All

Cheque Print Date : 24-Feb-2022 To 02-Mar-2022  
 Bank : 0099 To 1  
 Class : All

| Vendor Invoice                                            | Vendor Name Description |     |     |                                          | Batch Invc Date | Invc Due Date | Amount          |
|-----------------------------------------------------------|-------------------------|-----|-----|------------------------------------------|-----------------|---------------|-----------------|
| G.L. Account                                              | CC1                     | CC2 | CC3 | GL Account Name                          |                 |               |                 |
| <b>DEPARTMENT 3217 BACK HOE #4 - 2012 JOHN DEERE 410J</b> |                         |     |     |                                          |                 |               |                 |
| 2323                                                      |                         |     |     | LANDFILL BACKHOE REPAIRS AND MAINTENANCE | 15 28-Jan-2022  | 02-Mar-2022   |                 |
| 1-4-3217-2070                                             |                         |     |     | BH4 - Repairs & Maintenance              |                 |               | 1,106.56        |
| 2352                                                      |                         |     |     | REPAIRED BLOWN FUSE ON LANDFILL BACKHOE  | 15 28-Jan-2022  | 02-Mar-2022   |                 |
| 1-4-3217-2070                                             |                         |     |     | BH4 - Repairs & Maintenance              |                 |               | 718.59          |
| <b>03321 CURRIE TRUCK CENTRE</b>                          |                         |     |     |                                          |                 |               |                 |
| 0567587P                                                  |                         |     |     | DEF FLUID                                | 15 28-Jan-2022  | 02-Mar-2022   |                 |
| 1-4-3217-2070                                             |                         |     |     | BH4 - Repairs & Maintenance              |                 |               | 240.16          |
| <b>Department Totals :</b>                                |                         |     |     |                                          |                 |               | <b>2,065.31</b> |

|                                                    |  |  |  |                             |                |             |               |
|----------------------------------------------------|--|--|--|-----------------------------|----------------|-------------|---------------|
| <b>DEPARTMENT 3218 BACK HOE #5 - 2014 CASE 590</b> |  |  |  |                             |                |             |               |
| <b>03321 CURRIE TRUCK CENTRE</b>                   |  |  |  |                             |                |             |               |
| 0567587P                                           |  |  |  | DEF FLUID                   | 15 28-Jan-2022 | 02-Mar-2022 |               |
| 1-4-3218-2070                                      |  |  |  | BH5 - Repairs & Maintenance |                |             | 240.12        |
| <b>16075 GF PRESTON SALES AND SERVICE LTD.</b>     |  |  |  |                             |                |             |               |
| 96675                                              |  |  |  | REPAIRS TO BACKHOE          | 15 24-Jan-2022 | 02-Mar-2022 |               |
| 1-4-3218-2070                                      |  |  |  | BH5 - Repairs & Maintenance |                |             | 115.24        |
| <b>Department Totals :</b>                         |  |  |  |                             |                |             | <b>355.36</b> |

|                                                             |  |  |  |                                       |                |             |               |
|-------------------------------------------------------------|--|--|--|---------------------------------------|----------------|-------------|---------------|
| <b>DEPARTMENT 3222 TRUCK #22 - 2016 FREIGHTLINER TANDEM</b> |  |  |  |                                       |                |             |               |
| <b>03321 CURRIE TRUCK CENTRE</b>                            |  |  |  |                                       |                |             |               |
| 0567587P                                                    |  |  |  | DEF FLUID                             | 15 28-Jan-2022 | 02-Mar-2022 |               |
| 1-4-3222-2070                                               |  |  |  | TR22 - Repairs & Maintenance/licences |                |             | 240.12        |
| <b>07063 GILROY'S TIRE</b>                                  |  |  |  |                                       |                |             |               |
| 141618                                                      |  |  |  | 22" CLEAN AND SEAL - TRUCK 22 TIRES   | 15 24-Jan-2022 | 02-Mar-2022 |               |
| 1-4-3222-2070                                               |  |  |  | TR22 - Repairs & Maintenance/licences |                |             | 39.55         |
| <b>19008 SDB TRUCK &amp; EQUIPMENT REPAIRS</b>              |  |  |  |                                       |                |             |               |
| 12201                                                       |  |  |  | REPAIRS TO EXHAUST - TRUCK 22         | 15 19-Jan-2022 | 02-Mar-2022 |               |
| 1-4-3222-2070                                               |  |  |  | TR22 - Repairs & Maintenance/licences |                |             | 219.22        |
| 12219                                                       |  |  |  | MONTHLY INSPECTION - TRUCK 22         | 15 06-Feb-2022 | 02-Mar-2022 |               |
| 1-4-3222-2070                                               |  |  |  | TR22 - Repairs & Maintenance/licences |                |             | 169.50        |
| <b>Department Totals :</b>                                  |  |  |  |                                       |                |             | <b>668.39</b> |

|                                                              |  |  |  |                                       |                |             |               |
|--------------------------------------------------------------|--|--|--|---------------------------------------|----------------|-------------|---------------|
| <b>DEPARTMENT 3224 TRUCK #24 - 2012 INTERNATIONAL TANDEM</b> |  |  |  |                                       |                |             |               |
| <b>03321 CURRIE TRUCK CENTRE</b>                             |  |  |  |                                       |                |             |               |
| 0567587P                                                     |  |  |  | DEF FLUID                             | 15 28-Jan-2022 | 02-Mar-2022 |               |
| 1-4-3224-2070                                                |  |  |  | TR24 - Repairs & Maintenance/licences |                |             | 240.12        |
| <b>19008 SDB TRUCK &amp; EQUIPMENT REPAIRS</b>               |  |  |  |                                       |                |             |               |
| 12221                                                        |  |  |  | MONTHLY INSPECTION - TRUCK 24         | 15 06-Feb-2021 | 02-Mar-2022 |               |
| 1-4-3224-2070                                                |  |  |  | TR24 - Repairs & Maintenance/licences |                |             | 169.50        |
| <b>Department Totals :</b>                                   |  |  |  |                                       |                |             | <b>409.62</b> |

|                                                             |  |  |  |                                       |                |             |        |
|-------------------------------------------------------------|--|--|--|---------------------------------------|----------------|-------------|--------|
| <b>DEPARTMENT 3227 TRUCK #27 - 2014 FREIGHTLINER TANDEM</b> |  |  |  |                                       |                |             |        |
| <b>03321 CURRIE TRUCK CENTRE</b>                            |  |  |  |                                       |                |             |        |
| 0567587P                                                    |  |  |  | DEF FLUID                             | 15 28-Jan-2022 | 02-Mar-2022 |        |
| 1-4-3227-2070                                               |  |  |  | TR27 - Repairs & Maintenance/licences |                |             | 240.12 |

**MUNICIPALITY OF MAGNETAWAN**  
**Council/Board Report By Dept-(Computer)**

AP5130

Page : 8

Date : Feb 24, 2022

Time : 4:04 pm

Vendor : 01009 To 30000  
 Batch : 15 To 15  
 Department : All

Cheque Print Date : 24-Feb-2022 To 02-Mar-2022  
 Bank : 0099 To 1  
 Class : All

| Vendor Invoice                                              | Vendor Name Description                   |     |     |                 | Batch Invc Date | Invc Due Date | Amount        |
|-------------------------------------------------------------|-------------------------------------------|-----|-----|-----------------|-----------------|---------------|---------------|
| G.L. Account                                                | CC1                                       | CC2 | CC3 | GL Account Name |                 |               |               |
| <b>DEPARTMENT 3227 TRUCK #27 - 2014 FREIGHTLINER TANDEM</b> |                                           |     |     |                 |                 |               |               |
| <b>13021</b>                                                | <b>MAP SUNDRIDGE</b>                      |     |     |                 |                 |               |               |
| 753000/3                                                    | TRUCK 27 PARTS                            |     |     |                 | 15 24-Jan-2022  | 02-Mar-2022   |               |
| 1-4-3227-2070                                               | TR27 - Repairs & Maintenance/licences     |     |     |                 |                 |               | 295.79        |
| <b>19008</b>                                                | <b>SDB TRUCK &amp; EQUIPMENT REPAIRS</b>  |     |     |                 |                 |               |               |
| 12207                                                       | TRUCK 27 SERVICE CALL TO REPLACE MAXI POT |     |     |                 | 15 24-Jan-2022  | 02-Mar-2022   |               |
| 1-4-3227-2070                                               | TR27 - Repairs & Maintenance/licences     |     |     |                 |                 |               | 169.50        |
| 12217                                                       | MONTHLY INSPECTION - TRUCK 27             |     |     |                 | 15 06-Feb-2022  | 02-Mar-2022   |               |
| 1-4-3227-2070                                               | TR27 - Repairs & Maintenance/licences     |     |     |                 |                 |               | 169.50        |
| <b>Department Totals :</b>                                  |                                           |     |     |                 |                 |               | <b>874.91</b> |

|                                                      |                                          |  |  |  |                |             |                 |
|------------------------------------------------------|------------------------------------------|--|--|--|----------------|-------------|-----------------|
| <b>DEPARTMENT 3228 TRUCK #28 - 2018 WESTERN STAR</b> |                                          |  |  |  |                |             |                 |
| <b>03321</b>                                         | <b>CURRIE TRUCK CENTRE</b>               |  |  |  |                |             |                 |
| 0567587P                                             | DEF FLUID                                |  |  |  | 15 28-Jan-2022 | 02-Mar-2022 |                 |
| 1-4-3228-2070                                        | TR28 - Repairs & Maintenance/licences    |  |  |  |                |             | 240.12          |
| <b>13104</b>                                         | <b>MAGNETAWAN TRUCK AND TRAILER</b>      |  |  |  |                |             |                 |
| 656                                                  | SERVICE CALL TRUCK 28 - DEF TANK EMPTY   |  |  |  | 15 19-Jan-2022 | 02-Mar-2022 |                 |
| 1-4-3228-2070                                        | TR28 - Repairs & Maintenance/licences    |  |  |  |                |             | 100.57          |
| <b>19008</b>                                         | <b>SDB TRUCK &amp; EQUIPMENT REPAIRS</b> |  |  |  |                |             |                 |
| 12213                                                | TRUCK 28 AIR LEAK REPAIR                 |  |  |  | 15 01-Feb-2022 | 02-Mar-2022 |                 |
| 1-4-3228-2070                                        | TR28 - Repairs & Maintenance/licences    |  |  |  |                |             | 242.95          |
| 12218                                                | MONTHLY INSPECTION - TRUCK 28            |  |  |  | 15 06-Feb-2022 | 02-Mar-2022 |                 |
| 1-4-3228-2070                                        | TR28 - Repairs & Maintenance/licences    |  |  |  |                |             | 169.50          |
| 12223                                                | TRUCK 28 - REMOVE AND REPLACE RF SPRING  |  |  |  | 15 07-Feb-2022 | 02-Mar-2022 |                 |
| 1-4-3228-2070                                        | TR28 - Repairs & Maintenance/licences    |  |  |  |                |             | 1,582.00        |
| <b>Department Totals :</b>                           |                                          |  |  |  |                |             | <b>2,335.14</b> |

|                                                      |                                          |  |  |  |                |             |               |
|------------------------------------------------------|------------------------------------------|--|--|--|----------------|-------------|---------------|
| <b>DEPARTMENT 3229 TRUCK #29 - 2019 WESTERN STAR</b> |                                          |  |  |  |                |             |               |
| <b>03321</b>                                         | <b>CURRIE TRUCK CENTRE</b>               |  |  |  |                |             |               |
| 0567587P                                             | DEF FLUID                                |  |  |  | 15 28-Jan-2022 | 02-Mar-2022 |               |
| 1-4-3229-2070                                        | TR29 - Repairs & Maintenance/licences    |  |  |  |                |             | 240.12        |
| <b>19008</b>                                         | <b>SDB TRUCK &amp; EQUIPMENT REPAIRS</b> |  |  |  |                |             |               |
| 12208                                                | SERVICE CALL AND REPAIR - TRUCK 29       |  |  |  | 15 26-Jan-2022 | 02-Mar-2022 |               |
| 1-4-3229-2070                                        | TR29 - Repairs & Maintenance/licences    |  |  |  |                |             | 678.00        |
| <b>Department Totals :</b>                           |                                          |  |  |  |                |             | <b>918.12</b> |

|                                     |                                     |  |  |  |                |             |              |
|-------------------------------------|-------------------------------------|--|--|--|----------------|-------------|--------------|
| <b>DEPARTMENT 3800 STREETLIGHTS</b> |                                     |  |  |  |                |             |              |
| <b>15050</b>                        | <b>HYDRO ONE NETWORKS</b>           |  |  |  |                |             |              |
| 200029713087                        | AHMIC STREET LIGHTS                 |  |  |  | 15 03-Feb-2022 | 02-Mar-2022 |              |
| 1-4-3800-5014                       | STREET - Ahmic Harbour Street Light |  |  |  |                |             | 56.49        |
| 200126393189                        | LAKE CECEBE WHARF LIGHT             |  |  |  | 15 07-Feb-2022 | 02-Mar-2022 |              |
| 1-4-3800-5016                       | STREET - Rockwynn Landing Light     |  |  |  |                |             | 37.41        |
| <b>Department Totals :</b>          |                                     |  |  |  |                |             | <b>93.90</b> |

|                                           |                                         |  |  |  |  |  |  |
|-------------------------------------------|-----------------------------------------|--|--|--|--|--|--|
| <b>DEPARTMENT 4010 GARBAGE COLLECTION</b> |                                         |  |  |  |  |  |  |
| <b>16059</b>                              | <b>WASTE CONNECTIONS OF CANADA INC.</b> |  |  |  |  |  |  |

**MUNICIPALITY OF MAGNETAWAN**  
**Council/Board Report By Dept-(Computer)**

AP5130 Page : 9  
 Date : Feb 24, 2022 Time : 4:04 pm

Vendor : 01009 To 30000  
 Batch : 15 To 15  
 Department : All

Cheque Print Date : 24-Feb-2022 To 02-Mar-2022  
 Bank : 0099 To 1  
 Class : All

| Vendor Invoice                            | Vendor Name Description     | Batch | Inv Date       | Inv Due Date | Amount          |
|-------------------------------------------|-----------------------------|-------|----------------|--------------|-----------------|
| G.L. Account                              | CC1 CC2 CC3 GL Account Name |       |                |              |                 |
| <b>DEPARTMENT 4010 GARBAGE COLLECTION</b> |                             |       |                |              |                 |
| 7113-00003167                             | JAN/22 WASTE DISPOSAL       |       | 15 31-Jan-2022 | 02-Mar-2022  |                 |
| 1-4-4010-4010                             | GARBAGE - Contracts         |       |                |              | 2,000.38        |
| <b>Department Totals :</b>                |                             |       |                |              | <b>2,000.38</b> |

| <b>DEPARTMENT 4020 LANDFILL</b>                    |                                                          |  |                |             |                 |
|----------------------------------------------------|----------------------------------------------------------|--|----------------|-------------|-----------------|
| <b>13014 MAGNETAWAN BUILDING CENTRE (LANDFILL)</b> |                                                          |  |                |             |                 |
| 101-84401                                          | SUPPLIES                                                 |  | 15 31-Jan-2022 | 02-Mar-2022 |                 |
| 1-4-4020-2010                                      | LF - Materials/Supplies                                  |  |                |             | 98.26           |
| 101-84402                                          | BATTERY CHARGER                                          |  | 15 31-Jan-2022 | 02-Mar-2022 |                 |
| 1-4-4020-2010                                      | LF - Materials/Supplies                                  |  |                |             | 135.59          |
| 101-84725                                          | SUPPLIES                                                 |  | 15 05-Feb-2022 | 02-Mar-2022 |                 |
| 1-4-4020-2010                                      | LF - Materials/Supplies                                  |  |                |             | 30.39           |
| 101-85064                                          | SUPPLIES                                                 |  | 15 15-Feb-2022 | 02-Mar-2022 |                 |
| 1-4-4020-2010                                      | LF - Materials/Supplies                                  |  |                |             | 9.50            |
| <b>13242 MOORE PROPANE LIMITED</b>                 |                                                          |  |                |             |                 |
| 23015649                                           | CROFT LANDFILL PROPANE                                   |  | 15 24-Jan-2022 | 02-Mar-2022 |                 |
| 1-4-4020-2024                                      | LF - Propane Heat                                        |  |                |             | 125.44          |
| 23015978                                           | CHAPMAN LANDFILL PROPANE                                 |  | 15 08-Feb-2022 | 02-Mar-2022 |                 |
| 1-4-4020-2024                                      | LF - Propane Heat                                        |  |                |             | 96.23           |
| <b>16059 WASTE CONNECTIONS OF CANADA INC.</b>      |                                                          |  |                |             |                 |
| 7113-00003167                                      | JAN/22 WASTE DISPOSAL                                    |  | 15 31-Jan-2022 | 02-Mar-2022 |                 |
| 1-4-4020-4022                                      | LF - Mattress/Misc item disposal bin                     |  |                |             | 2,755.05        |
| <b>16075 GF PRESTON SALES AND SERVICE LTD.</b>     |                                                          |  |                |             |                 |
| 96752                                              | LANDFILL GENERATORS                                      |  | 15 01-Feb-2022 | 02-Mar-2022 |                 |
| 1-4-4020-8000                                      | LF - Capital Expenditures                                |  |                |             | 1,771.26        |
| <b>19046 CHARLES SAUNDERS</b>                      |                                                          |  |                |             |                 |
| 012614                                             | REIMBURSEMENT - SCREWDRIVERS AND SOCKET SET FOR LANDFILL |  | 15 11-Feb-2022 | 02-Mar-2022 |                 |
| 1-4-4020-2010                                      | LF - Materials/Supplies                                  |  |                |             | 301.67          |
| <b>20088 PHILPOTT TREVOR</b>                       |                                                          |  |                |             |                 |
| JAN30-FEB5/2                                       | LANDFILL MILEAGE JAN 30 - FEB 5/22                       |  | 15 05-Feb-2022 | 02-Mar-2022 |                 |
| 1-4-4020-2010                                      | LF - Materials/Supplies                                  |  |                |             | 82.35           |
| <b>Department Totals :</b>                         |                                                          |  |                |             | <b>5,405.74</b> |

| <b>DEPARTMENT 4030 RECYCLING</b>                   |                                      |  |                |             |          |
|----------------------------------------------------|--------------------------------------|--|----------------|-------------|----------|
| <b>13014 MAGNETAWAN BUILDING CENTRE (LANDFILL)</b> |                                      |  |                |             |          |
| 101-85064                                          | SUPPLIES                             |  | 15 15-Feb-2022 | 02-Mar-2022 |          |
| 1-4-4030-2010                                      | RECY - Materials/Supplies/Composting |  |                |             | 9.49     |
| <b>13242 MOORE PROPANE LIMITED</b>                 |                                      |  |                |             |          |
| 23015649                                           | CROFT LANDFILL PROPANE               |  | 15 24-Jan-2022 | 02-Mar-2022 |          |
| 1-4-4030-2024                                      | RECY - Propane Heat                  |  |                |             | 125.44   |
| 23015978                                           | CHAPMAN LANDFILL PROPANE             |  | 15 08-Feb-2022 | 02-Mar-2022 |          |
| 1-4-4030-2024                                      | RECY - Propane Heat                  |  |                |             | 96.24    |
| <b>16059 WASTE CONNECTIONS OF CANADA INC.</b>      |                                      |  |                |             |          |
| 7113-00003167                                      | JAN/22 WASTE DISPOSAL                |  | 15 31-Jan-2022 | 02-Mar-2022 |          |
| 1-4-4030-4012                                      | RECY - Recycling Curbside            |  |                |             | 2,045.99 |
| 1-4-4030-4014                                      | RECY - Recycling Depot               |  |                |             | 2,585.41 |



**MUNICIPALITY OF MAGNETAWAN**  
**Council/Board Report By Dept-(Computer)**

AP5130 Page : 10  
 Date : Feb 24, 2022 Time : 4.04 pm

Vendor : 01009 To 30000  
 Batch : 15 To 15  
 Department : All

Cheque Print Date : 24-Feb-2022 To 02-Mar-2022  
 Bank : 0099 To 1  
 Class : All

| Vendor Invoice                                 | Vendor Name Description                                                                          | Batch | Inv Date    | Inv Due Date | Amount          |
|------------------------------------------------|--------------------------------------------------------------------------------------------------|-------|-------------|--------------|-----------------|
| G.L. Account                                   | CC1 CC2 CC3 GL Account Name                                                                      |       |             |              |                 |
| <b>DEPARTMENT 4030 RECYCLING</b>               |                                                                                                  |       |             |              |                 |
| 7113-00003167<br>1-4-4030-4012                 | JAN/22 GARBAGE DISPOSAL<br>RECY - Recycling Curbside                                             | 15    | 14-Feb-2022 | 02-Mar-2022  | 68.00           |
| <b>16075 GF PRESTON SALES AND SERVICE LTD.</b> |                                                                                                  |       |             |              |                 |
| 96752<br>1-4-4030-8000                         | LANDFILL GENERATORS<br>RECY - Capital Expenditures                                               | 15    | 01-Feb-2022 | 02-Mar-2022  | 1,771.27        |
| <b>19046 CHARLES SAUNDERS</b>                  |                                                                                                  |       |             |              |                 |
| 012614<br>1-4-4030-2010                        | REIMBURSEMENT - SCREWDRIVERS AND SOCKET SET FOR LANDFILL<br>RECY - Materials/Supplies/Composting | 15    | 11-Feb-2022 | 02-Mar-2022  | 301.67          |
| <b>Department Totals :</b>                     |                                                                                                  |       |             |              | <b>7,003.51</b> |

|                                                      |                                         |    |             |             |                  |
|------------------------------------------------------|-----------------------------------------|----|-------------|-------------|------------------|
| <b>DEPARTMENT 6200 SOCIAL/FAMILY SERVICES</b>        |                                         |    |             |             |                  |
| <b>04010 DISTRICT OF PARRY SOUND SOCIAL SERVICES</b> |                                         |    |             |             |                  |
| JAN/2022<br>1-4-6200-2710                            | 2022 1ST QUARTER LEVY<br>SOCIAL - DSSAB | 15 | 31-Jan-2022 | 02-Mar-2022 | 76,650.21        |
| <b>Department Totals :</b>                           |                                         |    |             |             | <b>76,650.21</b> |

|                                                         |                                                        |    |             |             |                 |
|---------------------------------------------------------|--------------------------------------------------------|----|-------------|-------------|-----------------|
| <b>DEPARTMENT 6400 HEALTH SERVICES</b>                  |                                                        |    |             |             |                 |
| <b>14085 NORTH BAY PARRY SOUND DISTRICT HEALTH UNIT</b> |                                                        |    |             |             |                 |
| FEB/2022<br>1-4-6400-2010                               | FEBRUARY 2022 HEALTH UNIT LEVY<br>HEALTH - Health Unit | 15 | 10-Feb-2022 | 02-Mar-2022 | 3,493.19        |
| <b>Department Totals :</b>                              |                                                        |    |             |             | <b>3,493.19</b> |

|                                                 |                                                        |    |             |             |          |
|-------------------------------------------------|--------------------------------------------------------|----|-------------|-------------|----------|
| <b>DEPARTMENT 7200 PARKS</b>                    |                                                        |    |             |             |          |
| <b>13011 MAGNETAWAN BUILDING CENTRE (PARKS)</b> |                                                        |    |             |             |          |
| 101-84886<br>1-4-7200-2010                      | SNOW BRUSH<br>PARKS - Materials/Supplies               | 15 | 10-Feb-2022 | 02-Mar-2022 | 47.79    |
| 101-85016<br>1-4-7200-2010                      | SUPPLIES<br>PARKS - Materials/Supplies                 | 15 | 14-Feb-2022 | 02-Mar-2022 | 10.16    |
| 101-85024<br>1-4-7200-2010                      | SUPPLIES<br>PARKS - Materials/Supplies                 | 15 | 14-Feb-2022 | 02-Mar-2022 | 45.06    |
| 104-71557<br>1-4-7200-2010                      | AIR COMPRESSOR<br>PARKS - Materials/Supplies           | 15 | 25-Jan-2022 | 02-Mar-2022 | 132.20   |
| <b>13021 MAP SUNDRIDGE</b>                      |                                                        |    |             |             |          |
| 633210/3<br>1-4-7200-2010                       | SUPPLIES RETURNED CREDIT<br>PARKS - Materials/Supplies | 15 | 30-Oct-2019 | 02-Mar-2022 | -28.25   |
| <b>13240 JIM MOORE PETROLEUM</b>                |                                                        |    |             |             |          |
| 587894<br>1-4-7200-2024                         | DYED FURNACE OIL - PARKS GARAGE<br>PARKS - Heating     | 15 | 27-Jan-2022 | 02-Mar-2022 | 894.97   |
| <b>15050 HYDRO ONE NETWORKS</b>                 |                                                        |    |             |             |          |
| 200089680309<br>1-4-7200-2030                   | 18 MILLER ROAD<br>PARKS - Hydro                        | 15 | 24-Jan-2022 | 02-Mar-2022 | 205.84   |
| <b>19145 SIGNCRAFT CANADA INC.</b>              |                                                        |    |             |             |          |
| 1502<br>1-4-7200-2010                           | STREET SIGNS<br>PARKS - Materials/Supplies             | 15 | 28-Jan-2022 | 02-Mar-2022 | 2,983.20 |
| <b>20083 TRACKMATICS INC</b>                    |                                                        |    |             |             |          |

MUNICIPALITY OF MAGNETAWAN  
**Council/Board Report By Dept-(Computer)**

AP5130 Page : 11  
 Date : Feb 24, 2022 Time : 4:04 pm

Vendor : 01009 To 30000  
 Batch : 15 To 15  
 Department : All

Cheque Print Date : 24-Feb-2022 To 02-Mar-2022  
 Bank : 0099 To 1  
 Class : All

| Vendor Invoice                                                | Vendor Name Description            | Batch | Inv Date       | Inv Due Date | Amount          |
|---------------------------------------------------------------|------------------------------------|-------|----------------|--------------|-----------------|
| G.L. Account                                                  | CC1 CC2 CC3 GL Account Name        |       |                |              |                 |
| <b>DEPARTMENT 7200 PARKS</b>                                  |                                    |       |                |              |                 |
| 38252                                                         | MONTHLY GPS TRACKING - PARKS       | 15    | 05-Feb-2022    | 02-Mar-2022  |                 |
| 1-4-7200-2045                                                 | PARKS - GPS monitoring and data    |       |                |              | 118.65          |
| <b>Department Totals :</b>                                    |                                    |       |                |              | <b>4,409.62</b> |
| <hr/>                                                         |                                    |       |                |              |                 |
| <b>DEPARTMENT 7205 PARKS OVERHEAD</b>                         |                                    |       |                |              |                 |
| 15050                                                         | HYDRO ONE NETWORKS                 |       |                |              |                 |
| 200100056780                                                  | 6527 HWY 124                       |       | 15 01-Feb-2022 | 02-Mar-2022  |                 |
| 1-4-7205-2030                                                 | P - Hydro                          |       |                |              | 34.05           |
| <b>Department Totals :</b>                                    |                                    |       |                |              | <b>34.05</b>    |
| <hr/>                                                         |                                    |       |                |              |                 |
| <b>DEPARTMENT 7210 PARKS TRUCK #10 - 2010 DODGE 1500</b>      |                                    |       |                |              |                 |
| 04021                                                         | DEAN'S AUTO CARE                   |       |                |              |                 |
| 16618                                                         | 2010 RAM 1500 - OIL CHANGE         |       | 15 16-Feb-2022 | 02-Mar-2022  |                 |
| 1-4-7210-2070                                                 | TR10 - Repairs                     |       |                |              | 72.24           |
| <b>Department Totals :</b>                                    |                                    |       |                |              | <b>72.24</b>    |
| <hr/>                                                         |                                    |       |                |              |                 |
| <b>DEPARTMENT 7219 PARKS TRUCK #13 - 2020 GMC SIERRA 1500</b> |                                    |       |                |              |                 |
| 04021                                                         | DEAN'S AUTO CARE                   |       |                |              |                 |
| 16590                                                         | FILTERS AND OIL                    |       | 15 14-Feb-2022 | 02-Mar-2022  |                 |
| 1-4-7219-2070                                                 | TR13 - Repairs                     |       |                |              | 133.25          |
| <b>Department Totals :</b>                                    |                                    |       |                |              | <b>133.25</b>   |
| <hr/>                                                         |                                    |       |                |              |                 |
| <b>DEPARTMENT 7300 COMMUNITY CENTRE AND PAVILION</b>          |                                    |       |                |              |                 |
| 13011                                                         | MAGNETAWAN BUILDING CENTRE (PARKS) |       |                |              |                 |
| 101-84832                                                     | SNOW SHOVEL                        |       | 15 09-Feb-2022 | 02-Mar-2022  |                 |
| 1-4-7300-2010                                                 | HALL - Materials/Supplies          |       |                |              | 20.33           |
| 101-84885                                                     | SUPPLIES                           |       | 15 10-Feb-2022 | 02-Mar-2022  |                 |
| 1-4-7300-2010                                                 | HALL - Materials/Supplies          |       |                |              | 139.28          |
| 101-85158                                                     | SUPPLIES                           |       | 15 16-Feb-2022 | 02-Mar-2022  |                 |
| 1-4-7300-2010                                                 | HALL - Materials/Supplies          |       |                |              | 18.78           |
| 13240                                                         | JIM MOORE PETROLEUM                |       |                |              |                 |
| 588311                                                        | DYED FURNACE OIL - MCC             |       | 15 31-Jan-2022 | 02-Mar-2022  |                 |
| 1-4-7300-2024                                                 | HALL - Heating Fuel                |       |                |              | 1,358.92        |
| 588312                                                        | DYED FURNACE OIL - PAVILLON        |       | 15 31-Jan-2022 | 02-Mar-2022  |                 |
| 1-4-7300-2024                                                 | HALL - Heating Fuel                |       |                |              | 912.29          |
| 15068                                                         | ORKIN CANADA CORPORATION           |       |                |              |                 |
| C-3166109                                                     | MONTHLY JAN/22 PEST INSPECTION     |       | 15 22-Jan-2022 | 02-Mar-2022  |                 |
| 1-4-7300-2400                                                 | HALL - Repairs & Maintenance       |       |                |              | 253.12          |
| 19008                                                         | SDB TRUCK & EQUIPMENT REPAIRS      |       |                |              |                 |
| 12210                                                         | REPAIRS TO ZAMBONI                 |       | 15 27-Jan-2022 | 02-Mar-2022  |                 |
| 1-4-7300-3020                                                 | HALL - Zamboni Expenses            |       |                |              | 169.50          |
| 19055                                                         | STAPLES BUSINESS ADVANTAGE         |       |                |              |                 |
| 58532703                                                      | HAND SOAP                          |       | 15 14-Feb-2022 | 02-Mar-2022  |                 |
| 1-4-7300-2010                                                 | HALL - Materials/Supplies          |       |                |              | 71.41           |
| <b>Department Totals :</b>                                    |                                    |       |                |              | <b>2,943.63</b> |

MUNICIPALITY OF MAGNETAWAN  
**Council/Board Report By Dept-(Computer)**

AP5130 Page : 12  
 Date : Feb 24, 2022 Time : 4:04 pm

Vendor : 01009 To 30000  
 Batch : 15 To 15  
 Department : All

Cheque Print Date : 24-Feb-2022 To 02-Mar-2022  
 Bank : 0099 To 1  
 Class : All

| Vendor Invoice | Vendor Name Description     | Batch | Inv Date | Inv Due Date | Amount |
|----------------|-----------------------------|-------|----------|--------------|--------|
| G.L. Account   | CC1 CC2 CC3 GL Account Name |       |          |              |        |

DEPARTMENT 7300 COMMUNITY CENTRE AND PAVILION

DEPARTMENT 7700 AHMIC COMMUNITY CENTRE

13011 MAGNETAWAN BUILDING CENTRE (PARKS)

|               |          |                               |                |             |      |
|---------------|----------|-------------------------------|----------------|-------------|------|
| 101-84575     | SUPPLIES |                               | 15 03-Feb-2022 | 02-Mar-2022 |      |
| 1-4-7700-2400 |          | AHMIC - Repairs & Maintenance |                |             | 4.45 |

15050 HYDRO ONE NETWORKS

|               |                 |               |                |             |        |
|---------------|-----------------|---------------|----------------|-------------|--------|
| 200198932621  | 60 AHMIC STREET |               | 15 01-Feb-2022 | 02-Mar-2022 |        |
| 1-4-7700-2030 |                 | AHMIC - Hydro |                |             | 130.32 |

Department Totals : 134.77

DEPARTMENT 8010 PLANNING & DEVELOPMENT

05016 ECOVUE CONSULTING SERVICES

|               |                                 |                                          |                |             |        |
|---------------|---------------------------------|------------------------------------------|----------------|-------------|--------|
| 21-2125-306   | OFFICIAL PLAN BACKGROUND REPORT |                                          | 15 31-Jan-2022 | 02-Mar-2022 |        |
| 1-4-8010-5012 |                                 | PLN - Official Plan/Zoning Bylaw/2nd Dwe |                |             | 862.19 |

Department Totals : 862.19

Computer Paid Total : 212,102.29

|                                    |                   |
|------------------------------------|-------------------|
| Total Unpaid for Approval :        | 0.00              |
| Total Manually Paid for Approval : | 0.00              |
| Total Computer Paid for Approval : | 212,102.29        |
| Total EFT Paid for Approval :      | 0.00              |
| Grand Total ITEMS for Approval :   | <u>212,102.29</u> |

*BATCH 15*

MUNICIPALITY OF MAGNETAWAN  
**Council/Board Report By Dept-(EFT)**

AP5130

Date : Feb 24, 2022

Page : 1

Time : 4:06pm

Vendor : 01009 To 30000

Batch : 17 To 17

Department : All

EFT Paid Date : 01-Jan-2022 To 02-Mar-2022

Bank : 0099 To 1

Class : All

| Vendor Code                        | Vendor Name                               |     |     |                                    | Batch | Invc Date   | Invc Due Date | Amount           |
|------------------------------------|-------------------------------------------|-----|-----|------------------------------------|-------|-------------|---------------|------------------|
| Invoice No.                        | Description                               |     |     |                                    |       |             |               |                  |
| G.L. Account                       | CC1                                       | CC2 | CC3 | GL Account Name                    |       |             |               |                  |
| <b>DEPARTMENT 1000 LIABILITIES</b> |                                           |     |     |                                    |       |             |               |                  |
| 07068                              | <b>GREEN SHIELD CANADA EFT</b>            |     |     |                                    |       |             |               |                  |
| FEB/22                             | FEB/22 GREEN SHIELD GROUP BENEFIT PREMIUM |     |     |                                    |       |             |               |                  |
| 1-2-1000-1055                      |                                           |     |     | Benefits Payable - librarian       | 17    | 01-Feb-2022 | 15-Feb-2022   | 349.88           |
| 13023                              | <b>MANULIFE FINANCIAL EFT</b>             |     |     |                                    |       |             |               |                  |
| FEB/22                             | MANULIFE GROUP BENEFIT PREMIUM            |     |     |                                    |       |             |               |                  |
| 1-2-1000-1055                      |                                           |     |     | Benefits Payable - librarian       | 17    | 01-Feb-2022 | 15-Feb-2022   | 110.40           |
| 1-2-1000-1050                      |                                           |     |     | Benefits Payable                   |       |             |               | 1,148.60         |
| 18043                              | <b>RECEIVER GENERAL</b>                   |     |     |                                    |       |             |               |                  |
| FEB 1-15/22                        | FEB 1-15/22 PAYROLL REMITTANCE            |     |     |                                    |       |             |               |                  |
| 1-2-1000-1049                      |                                           |     |     | Income Tax Payable                 | 17    | 15-Feb-2022 | 15-Feb-2022   | 9,174.69         |
| 1-2-1000-1048                      |                                           |     |     | EI Payable                         |       |             |               | 1,802.62         |
| 1-2-1000-1047                      |                                           |     |     | CPP Payable                        |       |             |               | 5,772.62         |
| 18044                              | <b>RECEIVER GENERAL</b>                   |     |     |                                    |       |             |               |                  |
| FEB 1-15/22                        | FEB 1-15/22 PAYROLL REMITTANCE            |     |     |                                    |       |             |               |                  |
| 1-2-1000-1047                      |                                           |     |     | CPP Payable                        | 17    | 15-Feb-2022 | 15-Feb-2022   | 715.98           |
| 1-2-1000-1048                      |                                           |     |     | EI Payable                         |       |             |               | 272.84           |
| 1-2-1000-1049                      |                                           |     |     | Income Tax Payable                 |       |             |               | 744.47           |
| 18087                              | <b>ROYAL BANK VISA EFT</b>                |     |     |                                    |       |             |               |                  |
| FEB/22                             | ANNUAL VISA FEE                           |     |     |                                    |       |             |               |                  |
| 1-4-1000-2010                      |                                           |     |     | COUNCIL - Materials and Supplies   | 17    | 01-Feb-2022 | 15-Feb-2022   | 12.00            |
| 18089                              | <b>ROYAL BANK VISA EFT</b>                |     |     |                                    |       |             |               |                  |
| 324711419                          | GO TO MEETING FOR COUNCIL                 |     |     |                                    |       |             |               |                  |
| 1-4-1000-1310                      |                                           |     |     | COUNCIL - Conferences and Seminars | 17    | 29-Jan-2022 | 15-Feb-2022   | 29.38            |
| <b>Department Totals :</b>         |                                           |     |     |                                    |       |             |               | <b>20,133.48</b> |

|                                       |                                           |  |  |                                       |    |             |             |                 |
|---------------------------------------|-------------------------------------------|--|--|---------------------------------------|----|-------------|-------------|-----------------|
| <b>DEPARTMENT 1200 ADMINISTRATION</b> |                                           |  |  |                                       |    |             |             |                 |
| 07068                                 | <b>GREEN SHIELD CANADA EFT</b>            |  |  |                                       |    |             |             |                 |
| FEB/22                                | FEB/22 GREEN SHIELD GROUP BENEFIT PREMIUM |  |  |                                       |    |             |             |                 |
| 1-4-1200-1010                         |                                           |  |  | ADMIN - Wages and benefits            | 17 | 01-Feb-2022 | 15-Feb-2022 | 1,404.52        |
| 13023                                 | <b>MANULIFE FINANCIAL EFT</b>             |  |  |                                       |    |             |             |                 |
| FEB/22                                | MANULIFE GROUP BENEFIT PREMIUM            |  |  |                                       |    |             |             |                 |
| 1-4-1200-1010                         |                                           |  |  | ADMIN - Wages and benefits            | 17 | 01-Feb-2022 | 15-Feb-2022 | 611.19          |
| 18085                                 | <b>ROYAL BANK VISA EFT</b>                |  |  |                                       |    |             |             |                 |
| 498895307                             | REGISTERED LETTER                         |  |  |                                       |    |             |             |                 |
| 1-4-1200-2010                         |                                           |  |  | ADMIN - Office & Maintenance Supplies | 17 | 01-Feb-2022 | 15-Feb-2022 | 13.21           |
| 18086                                 | <b>ROYAL BANK VISA EFT</b>                |  |  |                                       |    |             |             |                 |
| FEB/22                                | ANNUAL VISA FEE                           |  |  |                                       |    |             |             |                 |
| 1-4-1200-2010                         |                                           |  |  | ADMIN - Office & Maintenance Supplies | 17 | 01-Feb-2022 | 15-Feb-2022 | 12.00           |
| 18089                                 | <b>ROYAL BANK VISA EFT</b>                |  |  |                                       |    |             |             |                 |
| 132034365                             | COFFEE                                    |  |  |                                       |    |             |             |                 |
| 1-4-1200-2015                         |                                           |  |  | ADMIN - Office maintenance & supplies | 17 | 08-Feb-2022 | 15-Feb-2022 | 77.98           |
| <b>Department Totals :</b>            |                                           |  |  |                                       |    |             |             | <b>2,118.90</b> |

|                                 |                                           |  |  |                            |    |             |             |        |
|---------------------------------|-------------------------------------------|--|--|----------------------------|----|-------------|-------------|--------|
| <b>DEPARTMENT 1300 TREASURY</b> |                                           |  |  |                            |    |             |             |        |
| 07068                           | <b>GREEN SHIELD CANADA EFT</b>            |  |  |                            |    |             |             |        |
| FEB/22                          | FEB/22 GREEN SHIELD GROUP BENEFIT PREMIUM |  |  |                            |    |             |             |        |
| 1-4-1300-1010                   |                                           |  |  | TREAS - Wages and benefits | 17 | 01-Feb-2022 | 15-Feb-2022 | 702.00 |

**MUNICIPALITY OF MAGNETAWAN**  
**Council/Board Report By Dept-(EFT)**

AP5130

Page : 2

Date : Feb 24, 2022

Time : 4:06pm

Vendor : 01009 To 30000

EFT Paid Date : 01-Jan-2022 To 02-Mar-2022

Batch : 17 To 17

Bank : 0099 To 1

Department : All

Class : All

| Vendor Code                     | Vendor Name                    | Batch | Inv Date    | Inv Due Date | Amount          |
|---------------------------------|--------------------------------|-------|-------------|--------------|-----------------|
| Invoice No.                     | Description                    |       |             |              |                 |
| G.L. Account                    | CC1 CC2 CC3 GL Account Name    |       |             |              |                 |
| <b>DEPARTMENT 1300 TREASURY</b> |                                |       |             |              |                 |
| 13023                           | MANULIFE FINANCIAL EFT         |       |             |              |                 |
| FEB/22                          | MANULIFE GROUP BENEFIT PREMIUM | 17    | 01-Feb-2022 | 15-Feb-2022  |                 |
| 1-4-1300-1010                   | TREAS - Wages and benefits     |       |             |              | 307.13          |
| 18085                           | ROYAL BANK VISA EFT            |       |             |              |                 |
| FEB/22                          | ANNUAL VISA FEE                | 17    | 01-Feb-2022 | 15-Feb-2022  |                 |
| 1-4-1300-2010                   | TREAS - Taxation Materials     |       |             |              | 12.00           |
| <b>Department Totals :</b>      |                                |       |             |              | <b>1,021.13</b> |

|                                        |                                           |    |             |             |               |
|----------------------------------------|-------------------------------------------|----|-------------|-------------|---------------|
| <b>DEPARTMENT 2000 FIRE DEPARTMENT</b> |                                           |    |             |             |               |
| 07068                                  | GREEN SHIELD CANADA EFT                   |    |             |             |               |
| FEB/22                                 | FEB/22 GREEN SHIELD GROUP BENEFIT PREMIUM | 17 | 01-Feb-2022 | 15-Feb-2022 |               |
| 1-4-2000-1010                          | FD - Wages & Benefits                     |    |             |             | 350.83        |
| 13023                                  | MANULIFE FINANCIAL EFT                    |    |             |             |               |
| FEB/22                                 | MANULIFE GROUP BENEFIT PREMIUM            | 17 | 01-Feb-2022 | 15-Feb-2022 |               |
| 1-4-2000-1010                          | FD - Wages & Benefits                     |    |             |             | 153.94        |
| <b>Department Totals :</b>             |                                           |    |             |             | <b>504.77</b> |

|                                             |                      |    |             |             |               |
|---------------------------------------------|----------------------|----|-------------|-------------|---------------|
| <b>DEPARTMENT 2005 FIRE MAG STATION</b>     |                      |    |             |             |               |
| 12045                                       | LAKELAND POWER - EFT |    |             |             |               |
| 072642-00 FEB. 81 ALBERT STREET - FIRE HALL |                      | 17 | 13-Feb-2022 | 15-Feb-2022 |               |
| 1-4-2005-2030                               | MAG STATION - Hydro  |    |             |             | 138.73        |
| <b>Department Totals :</b>                  |                      |    |             |             | <b>138.73</b> |

|                                            |                                           |    |             |             |               |
|--------------------------------------------|-------------------------------------------|----|-------------|-------------|---------------|
| <b>DEPARTMENT 2100 BUILDING DEPARTMENT</b> |                                           |    |             |             |               |
| 07068                                      | GREEN SHIELD CANADA EFT                   |    |             |             |               |
| FEB/22                                     | FEB/22 GREEN SHIELD GROUP BENEFIT PREMIUM | 17 | 01-Feb-2022 | 15-Feb-2022 |               |
| 1-4-2100-1010                              | CBO - Wages and benefits                  |    |             |             | 351.50        |
| 13023                                      | MANULIFE FINANCIAL EFT                    |    |             |             |               |
| FEB/22                                     | MANULIFE GROUP BENEFIT PREMIUM            | 17 | 01-Feb-2022 | 15-Feb-2022 |               |
| 1-4-2100-1010                              | CBO - Wages and benefits                  |    |             |             | 185.74        |
| <b>Department Totals :</b>                 |                                           |    |             |             | <b>537.24</b> |

|                                          |                                       |    |             |             |       |
|------------------------------------------|---------------------------------------|----|-------------|-------------|-------|
| <b>DEPARTMENT 2200 BYLAW ENFORCEMENT</b> |                                       |    |             |             |       |
| 18086                                    | ROYAL BANK VISA EFT                   |    |             |             |       |
| 043343                                   | PROPERTY INDEX MAP FOR BYLAW - ONLAND | 17 | 01-Feb-2022 | 15-Feb-2022 |       |
| 1-4-2200-2010                            | BLEO - Materials/Supplies             |    |             |             | 5.65  |
| 054849                                   | PROPERTY INDEX MAP FOR BYLAW - ONLAND | 17 | 01-Feb-2022 | 15-Feb-2022 |       |
| 1-4-2200-2010                            | BLEO - Materials/Supplies             |    |             |             | 5.65  |
| 066025                                   | PARCEL REGISTER FOR BY-LAW            | 17 | 01-Feb-2022 | 15-Feb-2022 |       |
| 1-4-2200-2010                            | BLEO - Materials/Supplies             |    |             |             | 33.82 |
| 18089                                    | ROYAL BANK VISA EFT                   |    |             |             |       |
| 081397                                   | PROPERTY INDEX MAP FOR BYLAW - ONLAND | 17 | 03-Feb-2022 | 15-Feb-2022 |       |
| 1-4-2200-2210                            | BLEO - Legal fees                     |    |             |             | 5.65  |
| 090228                                   | PARCEL REGISTER FOR BYLAW - ONLAND    | 17 | 03-Feb-2022 | 15-Feb-2022 |       |
| 1-4-2200-2210                            | BLEO - Legal fees                     |    |             |             | 33.82 |

MUNICIPALITY OF MAGNETAWAN  
**Council/Board Report By Dept-(EFT)**

AP5130

Date : Feb 24, 2022

Page : 3

Time : 4:06pm

Vendor : 01009 To 30000  
 Batch : 17 To 17  
 Department : All

EFT Paid Date : 01-Jan-2022 To 02-Mar-2022  
 Bank : 0099 To 1  
 Class : All

| Vendor Code                | Vendor Name                 | Batch | Inv Date | Inv Due Date | Amount       |
|----------------------------|-----------------------------|-------|----------|--------------|--------------|
| Invoice No.                | Description                 |       |          |              |              |
| G.L. Account               | CC1 CC2 CC3 GL Account Name |       |          |              |              |
| DEPARTMENT 2200            | BYLAW ENFORCEMENT           |       |          |              |              |
| <b>Department Totals :</b> |                             |       |          |              | <b>84.59</b> |

|                            |                                           |    |             |             |                 |
|----------------------------|-------------------------------------------|----|-------------|-------------|-----------------|
| DEPARTMENT 3101            | OVERHEAD                                  |    |             |             |                 |
| 07068                      | GREEN SHIELD CANADA EFT                   |    |             |             |                 |
| FEB/22                     | FEB/22 GREEN SHIELD GROUP BENEFIT PREMIUM | 17 | 01-Feb-2022 | 15-Feb-2022 |                 |
| 1-4-3101-1010              | J - Wages and benefits                    |    |             |             | 1,753.83        |
| 13023                      | MANULIFE FINANCIAL EFT                    |    |             |             |                 |
| FEB/22                     | MANULIFE GROUP BENEFIT PREMIUM            | 17 | 01-Feb-2022 | 15-Feb-2022 |                 |
| 1-4-3101-1010              | J - Wages and benefits                    |    |             |             | 726.65          |
| <b>Department Totals :</b> |                                           |    |             |             | <b>2,480.48</b> |

|                            |                                   |    |             |             |                 |
|----------------------------|-----------------------------------|----|-------------|-------------|-----------------|
| DEPARTMENT 3800            | STREETLIGHTS                      |    |             |             |                 |
| 12045                      | LAKELAND POWER - EFT              |    |             |             |                 |
| 073239-00 FEB.             | VILLAGE STREET LIGHTING           | 17 | 13-Feb-2022 | 15-Feb-2022 |                 |
| 1-4-3800-5012              | STREET - Magnetawan Street Lights |    |             |             | 969.95          |
| 077271-00 FEB.             | SPARKS STREET LIGHTING            | 17 | 13-Feb-2022 | 15-Feb-2022 |                 |
| 1-4-3800-5012              | STREET - Magnetawan Street Lights |    |             |             | 118.01          |
| <b>Department Totals :</b> |                                   |    |             |             | <b>1,087.96</b> |

|                            |                                           |    |             |             |               |
|----------------------------|-------------------------------------------|----|-------------|-------------|---------------|
| DEPARTMENT 4020            | LANDFILL                                  |    |             |             |               |
| 07068                      | GREEN SHIELD CANADA EFT                   |    |             |             |               |
| FEB/22                     | FEB/22 GREEN SHIELD GROUP BENEFIT PREMIUM | 17 | 01-Feb-2022 | 15-Feb-2022 |               |
| 1-4-4020-1010              | LF - Wages and benefits                   |    |             |             | 580.64        |
| 13023                      | MANULIFE FINANCIAL EFT                    |    |             |             |               |
| FEB/22                     | MANULIFE GROUP BENEFIT PREMIUM            | 17 | 01-Feb-2022 | 15-Feb-2022 |               |
| 1-4-4020-1010              | LF - Wages and benefits                   |    |             |             | 414.17        |
| <b>Department Totals :</b> |                                           |    |             |             | <b>994.81</b> |

|                            |                         |    |             |             |               |
|----------------------------|-------------------------|----|-------------|-------------|---------------|
| DEPARTMENT 6300            | BUILDING - 28 CHURCH ST |    |             |             |               |
| 12045                      | LAKELAND POWER - EFT    |    |             |             |               |
| 072641-00 FEB.             | 28 CHURCH STREET        | 17 | 13-Feb-2022 | 15-Feb-2022 |               |
| 1-4-6300-2030              | CHURCH ST - Hydro       |    |             |             | 372.16        |
| <b>Department Totals :</b> |                         |    |             |             | <b>372.16</b> |

|                 |                                            |    |             |             |          |
|-----------------|--------------------------------------------|----|-------------|-------------|----------|
| DEPARTMENT 7200 | PARKS                                      |    |             |             |          |
| 07068           | GREEN SHIELD CANADA EFT                    |    |             |             |          |
| FEB/22          | FEB/22 GREEN SHIELD GROUP BENEFIT PREMIUM  | 17 | 01-Feb-2022 | 15-Feb-2022 |          |
| 1-4-7200-1010   | PARKS - Wages and benefits                 |    |             |             | 1,051.33 |
| 12045           | LAKELAND POWER - EFT                       |    |             |             |          |
| 076283-00 FEB.  | 4135 HWY 520 - PARK LIGHTS                 | 17 | 13-Feb-2022 | 15-Feb-2022 |          |
| 1-4-7200-2030   | PARKS - Hydro                              |    |             |             | 48.73    |
| 076598-00 FEB.  | 61 SPARKS STREET - PUBLIC UTILITY BUILDING | 17 | 13-Feb-2022 | 15-Feb-2022 |          |
| 1-4-7200-2030   | PARKS - Hydro                              |    |             |             | 154.26   |
| 13023           | MANULIFE FINANCIAL EFT                     |    |             |             |          |
| FEB/22          | MANULIFE GROUP BENEFIT PREMIUM             | 17 | 01-Feb-2022 | 15-Feb-2022 |          |
| 1-4-7200-1010   | PARKS - Wages and benefits                 |    |             |             | 371.92   |

MUNICIPALITY OF MAGNETAWAN  
**Council/Board Report By Dept-(EFT)**

AP5130 Page : 4  
 Date : Feb 24, 2022 Time : 4:06pm

Vendor : 01009 To 30000  
 Batch : 17 To 17  
 Department : All

EFT Paid Date : 01-Jan-2022 To 02-Mar-2022  
 Bank : 0099 To 1  
 Class : All

| Vendor Code                | Vendor Name                                        |     |     |                         | Batch | Inv Date    | Inv Due Date | Amount          |
|----------------------------|----------------------------------------------------|-----|-----|-------------------------|-------|-------------|--------------|-----------------|
| Invoice No.                | Description                                        |     |     |                         |       |             |              |                 |
| G.L. Account               | CC1                                                | CC2 | CC3 | GL Account Name         |       |             |              |                 |
| DEPARTMENT 7200            |                                                    |     |     | PARKS                   |       |             |              |                 |
| 18091                      | ROYAL BANK VISA EFT                                |     |     |                         |       |             |              |                 |
| 3062725                    | WALERTON CLEAN WATER - WATER SYSTEM CORRESPONDENCE |     |     |                         | 17    | 08-Feb-2022 | 15-Feb-2022  |                 |
| 1-4-7200-2020              |                                                    |     |     | PARKS - Safety & Health |       |             |              | 237.30          |
| <b>Department Totals :</b> |                                                    |     |     |                         |       |             |              | <b>1,863.54</b> |

|                             |                      |  |  |                               |    |             |             |                 |
|-----------------------------|----------------------|--|--|-------------------------------|----|-------------|-------------|-----------------|
| DEPARTMENT 7300             |                      |  |  | COMMUNITY CENTRE AND PAVILION |    |             |             |                 |
| 12045                       | LAKELAND POWER - EFT |  |  |                               |    |             |             |                 |
| 073252-00 FEB. 4304 HWY 520 |                      |  |  |                               | 17 | 13-Feb-2022 | 15-Feb-2022 |                 |
| 1-4-7300-2030               |                      |  |  | HALL - Hydro/Stove Propane    |    |             |             | 1,628.63        |
| <b>Department Totals :</b>  |                      |  |  |                               |    |             |             | <b>1,628.63</b> |

|                                               |                      |  |  |                  |    |             |             |              |
|-----------------------------------------------|----------------------|--|--|------------------|----|-------------|-------------|--------------|
| DEPARTMENT 7600                               |                      |  |  | HERITAGE CENTRE  |    |             |             |              |
| 12045                                         | LAKELAND POWER - EFT |  |  |                  |    |             |             |              |
| 072693-00 FEB. 4205 HWY 520 - HERITAGE CENTRE |                      |  |  |                  | 17 | 13-Feb-2022 | 15-Feb-2022 |              |
| 1-4-7600-2030                                 |                      |  |  | HERITAGE - Hydro |    |             |             | 98.38        |
| <b>Department Totals :</b>                    |                      |  |  |                  |    |             |             | <b>98.38</b> |

|                            |                                |  |  |                            |    |             |             |              |
|----------------------------|--------------------------------|--|--|----------------------------|----|-------------|-------------|--------------|
| DEPARTMENT 7700            |                                |  |  | AHMIC COMMUNITY CENTRE     |    |             |             |              |
| 18089                      | ROYAL BANK VISA EFT            |  |  |                            |    |             |             |              |
| 6387447                    | AHMIC HARBOUR - BULLETIN BOARD |  |  |                            | 17 | 09-Feb-2022 | 15-Feb-2022 |              |
| 1-4-7700-2010              |                                |  |  | AHMIC - Materials/Supplies |    |             |             | 87.00        |
| <b>Department Totals :</b> |                                |  |  |                            |    |             |             | <b>87.00</b> |

**EFT Paid Total : 33,151.80**

|                                         |                  |
|-----------------------------------------|------------------|
| Total Unpaid for Approval :             | 0.00             |
| Total Manually Paid for Approval :      | 0.00             |
| Total Computer Paid for Approval :      | 0.00             |
| Total EFT Paid for Approval :           | 33,151.80        |
| <b>Grand Total ITEMS for Approval :</b> | <b>33,151.80</b> |

*BATCH 17*

**THE CORPORATION OF THE MUNICIPALITY OF MAGNETAWAN**

**BY-LAW NO. 2022 -**

**Being a By-law to establish a Committee of Adjustment for the Municipality of Magnetawan for 2022**

---

**WHEREAS** Section 44(1) of the Planning Act, R.S.O. 1990, Chapter P.13, authorizes a municipality to constitute and appoint a Committee of Adjustment;

**AND WHEREAS** Section 44(3) of the Planning Act, R.S.O. 1990, Chapter P.13, the members of the committee who are members of a municipal council shall be appointed annually;

**AND WHEREAS** Section 45 (1) The committee of adjustment, upon the application of the owner of any land, building or structure affected by any by-law that is passed under section 34 or 38, or a predecessor of such sections, or any person authorized in writing by the owner, may, despite any other Act, authorize such minor variance from the provisions of the by-law, in respect of the land, building or structure or the use thereof, as in its opinion is desirable for the appropriate development or use of the land, building or structure, if in the opinion of the committee the general intent and purpose of the by-law and of the official plan, if any, are maintained;

**AND WHEREAS** Section 45 (3) A council that has constituted a committee of adjustment may by by-law empower the committee of adjustment to grant minor variances from the provisions of any by-law of the municipality that implements an official plan, or from such by-laws of the municipality as are specified and that implement an official plan, and when a committee of adjustment is so empowered subsection (1) applies with necessary modifications. R.S.O. 1990, c. P.13, s. 45 (3);

**NOW THEREFORE** the Council of the Corporation of the Municipality of Magnetawan hereby enacts as follows:

1. **THAT** the following persons, all of whom are members of Council, are hereby appointed as its members for the 2022 calendar year until the inauguration of the newly elected Council:
  - Sam Dunnett
  - Tim Brunton
  - John Hetherington
  - Brad Kneller
  - Wayne Smith
2. **THAT** the Committee of Adjustment shall be hereby empowered with the authority to grant minor variances from the provisions of any by-law of the municipality that implements an Official Plan.
3. That the Clerk of the Municipality of Magnetawan is hereby appointed as the Secretary-Treasurer of the Committee of Adjustment. The Clerk may delegate to any employee of the Municipality of Magnetawan all, or a portion of, the duties of Secretary-Treasurer of the Committee of Adjustment.
4. **THAT** this By-law shall come into force and effect on January 01, 2022.

**READ A FIRST, SECOND AND THIRD TIME**, passed, signed and the Seal of the Corporation affixed hereto, this ..... day of .....,2022.



**THE CORPORATION OF THE MUNICIPALITY OF MAGNETAWAN**

**BY-LAW NO. 2022 -**

**Being a By-law to confirm the proceedings of Council March 02, 2022**

---

**WHEREAS** Section 5(3) of the *Municipal Act, 2001, S.O. 2001, c.25*, as amended, requires a municipal Council to exercise a municipal power, including a municipality's capacity, rights, powers and privileges under Section 9, by by-law unless the municipality is specifically authorized to do otherwise;

**AND WHEREAS** the Council of the Municipality of Magnetawan deems it desirable to confirm the proceedings of Council and to ratify decisions made at its meeting hereinafter set out;

**NOW THEREFORE** the Council of the Corporation of the Municipality of Magnetawan enacts as follows:

**1. Ratification and Confirmation**

**THAT** the action of the Council of the Municipality of Magnetawan at its meeting for the aforementioned date(s) with respect to each motion, resolution and other action passed and taken by this Council at its meetings, except where otherwise required, is hereby adopted, ratified and confirmed as if such proceedings and actions were expressly adopted and confirmed by its separate By-law.

**2. Execution of all Documents**

**THAT** the Mayor of the Council of the Municipality of Magnetawan and the proper officers of the Municipality of Magnetawan are hereby authorized and directed to do all things necessary to give effect to the said action or to obtain approvals where required, except where otherwise provided, and the Mayor and Clerk are hereby authorized and directed to execute all necessary documents and to affix the Corporate Seal of the Municipality to such documents.

**READ A FIRST, SECOND, AND THIRD TIME**, passed, signed and the Seal of the Corporation affixed hereto, this 2nd day of March 2022.

**THE CORPORATION OF THE  
MUNICIPALITY OF MAGNETAWAN**

---

Mayor

---

CAO/Clerk

*Indese*  
*March 2, 2022*

**2022 Budget Sheets - Actuals as of December 31st, 2021**  
**Regional Economic Development**  
**Operating Budget - Page 1**

| GL Number  | Description                                         | 2021 Actual           | 2021 Budgeted      | 2022 Department Estimate | Notes                                                          |
|------------|-----------------------------------------------------|-----------------------|--------------------|--------------------------|----------------------------------------------------------------|
|            | <b>Revenues</b>                                     |                       |                    |                          |                                                                |
| 13-807-000 | ACED surplus                                        | \$0.00                | \$0.00             | \$0.00                   | Note 1: Transferred from prior year's surplus.                 |
| 15-370-000 | <b>Municipal &amp; Chamber Contributions</b>        |                       |                    |                          |                                                                |
|            | Armour                                              | (\$10,000.00)         | (\$10,000)         | (\$10,000)               |                                                                |
|            | Burk's Falls                                        | (\$10,000.00)         | (\$10,000)         | (\$10,000)               |                                                                |
|            | Joly                                                | (\$5,000.00)          | (\$5,000)          | (\$5,000)                |                                                                |
|            | Magnetawan                                          | (\$10,000.00)         | (\$10,000)         | (\$7,500)                | Note 2: Contribution for period ending Sept. 30, 2021.         |
|            | Perry                                               | (\$10,000.00)         | (\$10,000)         | (\$10,000)               |                                                                |
|            | Powassan                                            | (\$10,000.00)         | (\$10,000)         | (\$10,000)               |                                                                |
|            | Ryerson                                             | (\$10,000.00)         | (\$10,000)         | (\$10,000)               |                                                                |
|            | South River                                         | (\$10,000.00)         | (\$10,000)         | (\$10,000)               |                                                                |
|            | Strong                                              | (\$10,000.00)         | (\$10,000)         | (\$10,000)               |                                                                |
|            | Sundridge                                           | (\$10,000.00)         | (\$10,000)         | (\$10,000)               |                                                                |
|            | Chamber of Commerce                                 | (\$10,000.00)         | (\$10,000)         | (\$10,000)               |                                                                |
|            | Total Municipal & Chamber Contri.                   | (\$105,000.00)        | (\$105,000)        | (\$102,500)              |                                                                |
| 15-370-005 | User fees - Almaguin Harvest Spin                   | \$0.00                | (\$10,000)         | \$0                      |                                                                |
| 15-370-008 | Staycation contributions                            | (\$15,250.00)         | \$0                | \$0                      |                                                                |
| 15-371-000 | CIINO Funding                                       | (\$128,264.00)        | (\$129,500)        | (\$162,000)              | Note 3: Represents 84.27% of total salaries + 28% in benefits. |
| 15-371-002 | FedNor - Harvest Spin/Staycation                    | (\$19,717.00)         | (\$19,717)         | \$0                      |                                                                |
| 15-371-003 | FedNor - Implement Brand Strategy                   | (\$6,071.00)          | (\$40,000)         | (\$86,000)               | Note 4: 36.17% of \$239,000. Combined with GL 15-372-003.      |
| 15-371-005 | OBIAA Funding - Intern                              | (\$4,897.21)          | (\$4,850)          | \$0                      |                                                                |
| 15-371-007 | NECO - Staycation Program                           | (\$10,000.00)         | \$0                | \$0                      | Note 5: Applied for and disbursed in 2021 (non-budgeted).      |
| 15-371-008 | NECO - Regional Relief & Recovery                   | \$0.00                | \$0                | \$0                      | Note 6: Non active. Applied for and disbursed in 2020.         |
| 15-372-000 | NOHFC Funding - Intern                              | (\$22,883.14)         | (\$7,280)          | \$0                      | Note 7: Internship closed Sept. 30, 2021.                      |
| 15-372-001 | NOHFC - Almaguin Harvest Spin                       | \$0.00                | (\$15,000)         | \$0                      | Note 8: Application not submitted in favour of Reconnect.      |
| 15-372-002 | NOHFC - Almaguin Brand Strategy                     | \$0.00                | \$0                | \$0                      | Note 9: Final payment retroactively paid in 2020.              |
| 15-372-003 | RED - Implement Brand Strategy                      | (\$8,392.00)          | (\$60,000)         | (\$119,500)              | Note 10: 50% of \$239,000. Combined with GL 15-371-002.        |
| 15-373-001 | MHSTIC - Reconnect Grant                            | (\$18,800.00)         | \$0                | \$0                      |                                                                |
|            |                                                     |                       |                    |                          |                                                                |
|            | <b>Total Regional Economic Development revenues</b> | <b>(\$339,274.35)</b> | <b>(\$391,347)</b> | <b>(\$470,000)</b>       |                                                                |

| GL Number  | Expenditures                               | Item Cost          | Budget AMT |
|------------|--------------------------------------------|--------------------|------------|
| 16-804-001 | Office Supplies                            |                    | \$3,000    |
|            | Office 365 (5 user)                        | \$ 100             |            |
|            | Kaspersky A/V (5 user)                     | \$ 100             |            |
|            | Survey Monkey                              | \$ 460             |            |
|            | Zoom Account                               | \$ 280             |            |
|            | Adobe Creative Cloud                       | \$ 985             |            |
|            | Misc Supplies                              | \$ 1,075           |            |
|            | <b>Total</b>                               | <b>\$ 3,000</b>    |            |
| 16-804-010 | Advertising & Promotion (General)          |                    | \$4,500    |
| 16-804-025 | Website                                    |                    | \$2,000    |
|            | Domain, hosting & email fees (2 sites)     | \$ 600             |            |
|            | Website Contingency                        | \$ 1,400           |            |
|            | <b>Total</b>                               | <b>\$ 2,000</b>    |            |
| 16-804-030 | Events & Seminars                          |                    | \$4,000    |
|            | Business Support Events                    | \$ 2,000.00        |            |
|            | AHCC Partnerships                          | \$ 2,000.00        |            |
|            | <b>Total</b>                               | <b>\$ 4,000.00</b> |            |
| 16-804-040 | Training & Workshops                       |                    | \$4,000    |
|            | EDCO & EDAC memberships                    | \$ 1,500           |            |
|            | Professional Development                   | \$ 1,000           |            |
|            | General Admission Fees(Conferences, etc)   | \$ 1,500           |            |
|            | <b>Total</b>                               | <b>\$ 4,000</b>    |            |
| 16-804-064 | Almaguin Brand Strategy                    |                    | \$169,428  |
|            | Almaguin Website Development               | \$ 15,000          |            |
|            | Third Party Implementation Support         | \$ 20,000          |            |
|            | Brand Ambassador Programming               | \$ 10,000          |            |
|            | Regional Guide Creation, Mapping and Print | \$ 20,000          |            |
|            | Photography and Videography                | \$ 20,000          |            |
|            | Brand Adoption & Awareness                 | \$ 20,000          |            |
|            | Marketing Partnership Program              | \$ 64,428          |            |
|            | <b>Total</b>                               | <b>\$ 169,428</b>  |            |
| 16-804-065 | Regional Projects                          |                    | \$10,203   |
|            | Project 1E - Win this Space                | \$ 1,000           |            |
|            | Project 2A - Community G.R.O.              | \$ 2,000           |            |
|            | Project 3C - Carpool Almaguin              | \$ 2,500           |            |
|            | Project 4B - Ag Streategy                  | \$ 1,703           |            |
|            | Project 4D - Shop in Almaguin              | \$ 1,000           |            |
|            | Project 5A - RED Gala                      | \$ 2,000           |            |
|            | <b>Total</b>                               | <b>\$ 10,203</b>   |            |



Statistics  
Canada

Statistique  
Canada

on desk March 2, 2022

[Home](#) > [Census of Population](#) > [Data products, 2021 Census](#)

> [Census Profile, 2021 Census of Population](#) > [Search results for "Magnetawan"](#)

Census Profile, 2021 Census of Population

## Data table

### Magnetawan, Municipality (MU) ⓘ

Ontario

[Census subdivision]

Counts

| Characteristic                                                | Total  |
|---------------------------------------------------------------|--------|
| <b>Population and dwellings</b>                               |        |
| Population, 2021 <sup>1</sup>                                 | 1,753  |
| Population, 2016 <sup>1</sup>                                 | 1,390  |
| Population percentage change,<br>2016 to 2021                 | 26.1   |
| Total private dwellings <sup>2</sup>                          | 1,717  |
| Private dwellings occupied by<br>usual residents <sup>3</sup> | 825    |
| Population density per square<br>kilometre                    | 3.3    |
| Land area in square kilometres                                | 526.31 |

**Source:** Statistics Canada, 2021 Census of Population.